

GPXL 0.2W 3535RGB

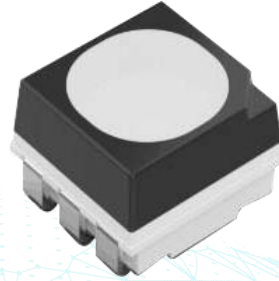

承认书 Approve Sheet

产品 /Product	LED	
型号/Part Number	YLL-T3535RGB-3-AEJ	
物料编码 (Material Code)	8037122399S	
客户规格/customer specification		
客户/Customer		
光通量 (lm) /亮度 (mcd)	R: 700-1100mcd/R: 620-630nm G: 1600-2400mcd/G: 520-530nm B: 400-700mcd/B: 460-470nm	
电压/VF (V)	R: 2.0-2.5V/G: 2.6-3.3V/B: 2.8-3.4V	
色区等级/Color Bin		
显色指数/CRI		
色容差/SDCM		
备注/remarks		
制定/Maker		
制作/Prepared	审核/Checked	客户回签/Customer Confirmation

特性 (Feature)

- Size (mm) : 3.5*3.5mm
尺寸 (mm) : 3.5*3.5mm
- 0.2W Low Power LED
0.2W 小功率 LED 产品
- 高度: 2.8mm
Height (mm) : 2.8mm
- Suitable for all SMT assembly
And solder process.
适用于所有的 SMT 组装和焊接工艺
- Moisture sensitivity level: Level 4.
防潮等级 Level 4.

建议使用范围 (Suggested scope of use)

- ◆ Outdoor landscape brightening
户外景观亮化
- ◆ Led Screen & Display
户外屏

产品尺寸图 Product Structure diagram.

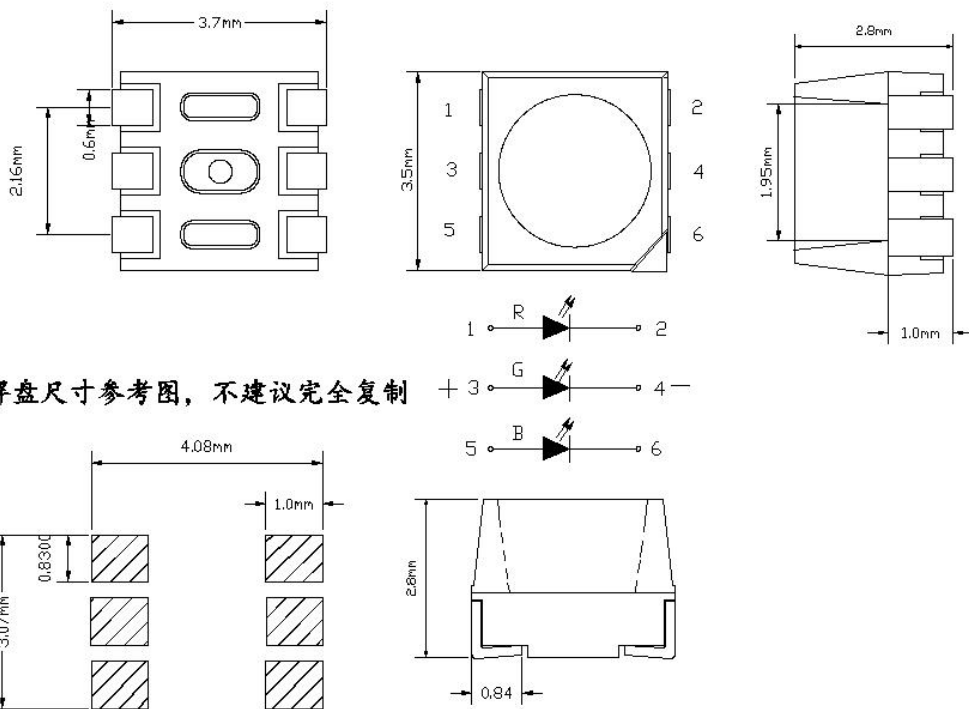

Notes: (备注)

All dimension units are millimeters.

所有标注尺寸单位为毫米。

材质说明 Material Description

型号 Part No.	芯片材料 Chip Materials	胶体类型 Lens Type
YLL-T3535RGB-3-AEBJ	InGaN/AlGaInP	A translucent colloid (半透明胶体)

极限参数范围值 Absolute Maximum Ratings at TA=25°C

参数 (Parameter)	符号 (Symbol)	值 (Rating)	单位 (Units)
消耗功率 (Power Dissipation)	Pd	200	mw
连续工作电流 (Continuous Forward Current)	IF	3*20	mA
顺向脉冲电流 Pulsed Forward Current (1/10Duty Cycle, 0.1ms Pulsewidth)	IFP	3*30	mA
反向电压 (Reverse Voltage)	VR	5	V
静电 (Electrostatic Discharge) (HBM)	ESD	R 3000	V
		G 2000	
		B 2000	
操作温度 (Operating Temperature)	Topr	-40 to +80	°C
储存条件 Storage Condition	Tstg	-40 to +100	°C
	Humidity	<60	%
结温 (Junction Temperature)	Tj	≤125	°C
热阻 (Thermal Resistance)	Rthj-s	R 150	°C/W
		G 200	
		B 200	

备注 (Note) :

脉宽 0.1ms, 周期 1/10 (1/10 Duty cycle, 0.1ms pulse width.)

光电参数特性 Electrical / Optical Characteristics at TA=25°C

Parameter	符号 Symbol	最小值 Min	中间值 Typ	最大值 Max	单位 Unit	测试条件 Test Condition
亮度 Luminous Intensity	IV	R	700		1100	mcd IF=3*20mA
		G	1600		2400	
		B	400		700	
发光角度 Viewing Angle	2θ 1/2		120		deg	Note 1
波长 Dominant Wavelength	λ d	R	620		630	nm IF=3*20mA
		G	520		530	
		B	460		470	
电压 Forward Voltage (R)	VF	R	2.0		2.5	V IF=3*20mA
		G	2.6		3.3	
		B	2.8		3.4	
反向电流 ReverseCurrent	IR	--	--	10	μA	VR=5V

Note (备注) :

- 1/2 is the angle from optical centerline where the luminous intensity is 1/2 the optical centerline value
1/2 是半值角, 指光强是光学中心线光强的 1/2 处到光学中心线的角度
- The above luminous flux measurement allowance tolerance is ±15%.
上述发光通量的测试允许公差为 ±15%
- The above Color Rendering Index measurement allowance tolerance is ±2
以上显色性指数的测试允许公差为 ±2
- The above forward voltage measurement allowance tolerance is ±0.1V
以上所示电压测量误差 ±0.1V

典型光学特性曲线 Typical optical characteristics curves

Forward Voltage VS. Forward Current
正向电压与正向电流特性曲线

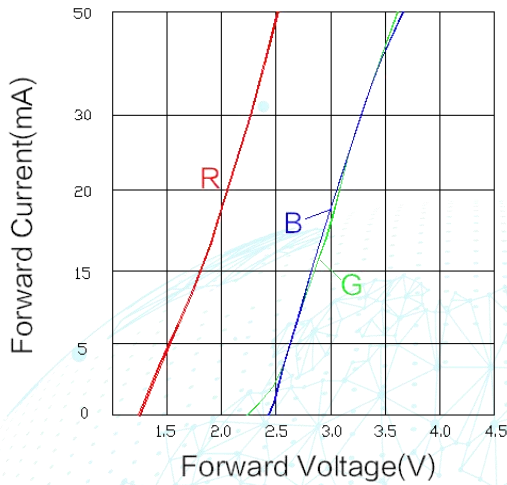

Forward Current VS. Relative Intensity
正向电流与相对光强特性曲线

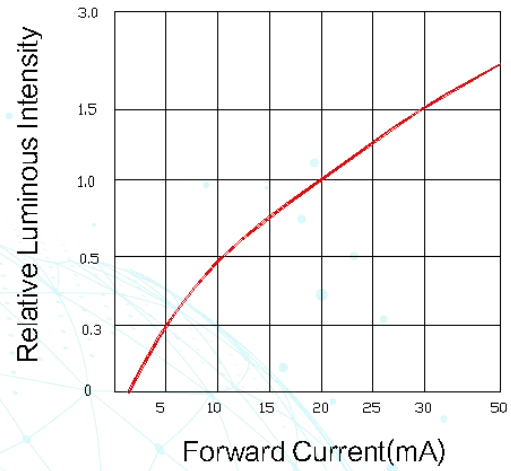

Ambient Temperature VS. Relative Intensity
环境温度与相对光强特性曲线

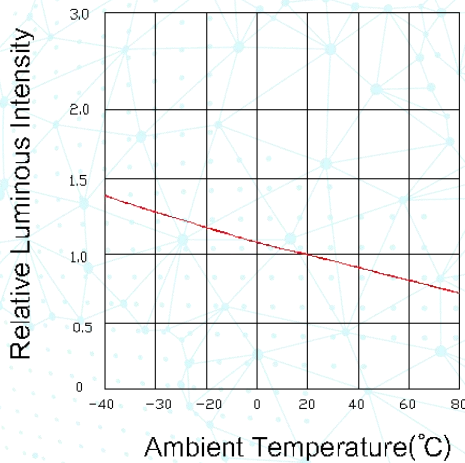

Soldering Temperature VS. Forward Current
焊盘温度与正向电流特性曲线

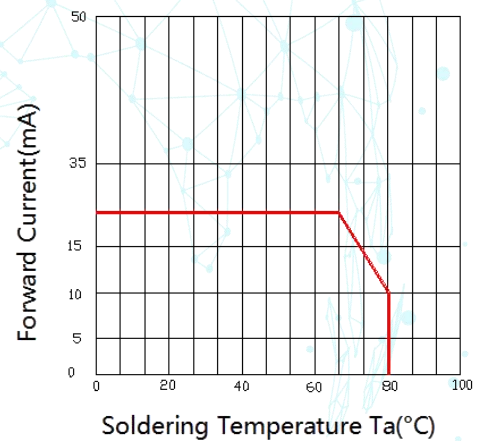

Relative Spectral emission
相对光谱分布特性曲线

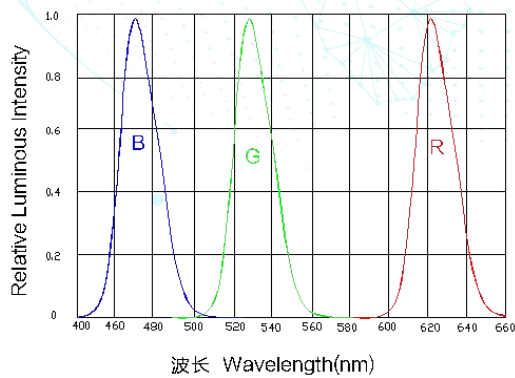

Radiation diagram
辐射角度图

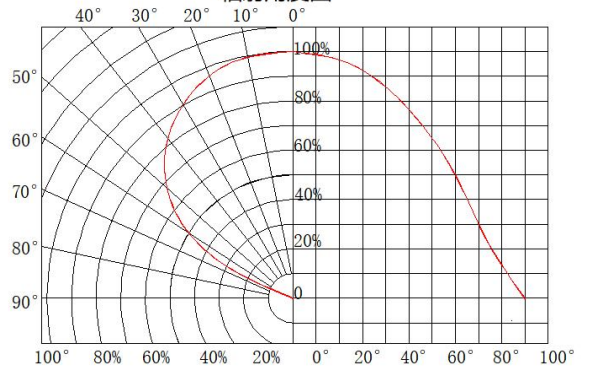

信赖性测试项目及条件 Reliability Test Items And Conditions

Test Items 项目	Ref. Standard 参考标准	Test Condition 测试条件	Time 时间	Quantity 数量	Ac/Re 接收/拒收
回流焊 Reflow	IEC/TR 60068-3-12-2014	Temp:260°C max T=8 sec	3 times	22PCS	0/1
冷热冲击 Hot and cold impact	IEC60068-2-14 :2009	120°C±3°C 30min ↑↓5 min -40°C±3°C 30min	500 Cycles	100PCS	0/1
红墨水实验 Red ink experiment	/	将回流焊一次后成品灯珠放入装有红墨水的烧杯中。	浸泡 16H	100PCS	0/1
裸灯高温高湿存储 Bare lamp for high temperature and high humidity storage	/	Ta=85°C RH=85%	168H	22PCS	0/1
		Temp:260°C/10min	3 times		
裸灯高温高湿存储 Bare lamp for high temperature and high humidity storage	/	Ta=85°C RH=85%	1000H	22PCS	0/1
		Temp:260 max T=10sec	3 times		
湿气入侵模拟测试 Moisture intrusion simulation test	/	Ta=85°C RH=85%	1000H	100PCS	0/1
防潮等级测试 Moisture proof level test	/	将灯珠室温环境下裸放，每周对灯珠进行喷水加湿 3-5 次。	1 个月	100PCS	0/1
		Temp:260 max T=8sec	3 times		
高温高湿老化测试 High Humidity Heat Life Test	IEC60068-2-78: 2001	Ta=85°C RH=85% 30min 亮/30min 灭 IF=3*20mA	1000H	22PCS	0/1

失效判定标准 Failure Criteria

项目 Test Items	符号 Symbol	测试条件 Test Condition	判定标准 Failure Criteria	
			最小 (MIN)	最大 (MAX)
正向电压	VF	IF=3*20mA	--	U. S. L*)x1.1
反向电流	IR	VR = 5V	--	10uA
光通量	Im	IF=3*20mA	L. S. L*)x0.7	

U. S. L: Upper Specification Limit 规格上限

L. S. L: Lower Specification Limit 规格下限

回流焊说明 SMT Reflow Soldering Instructions SMT

回流焊说明 Reflow Soldering Instructions

本产品最多只可回焊一次 Number of reflow process shall be less than 1 times

有铅回焊 Lead Solder

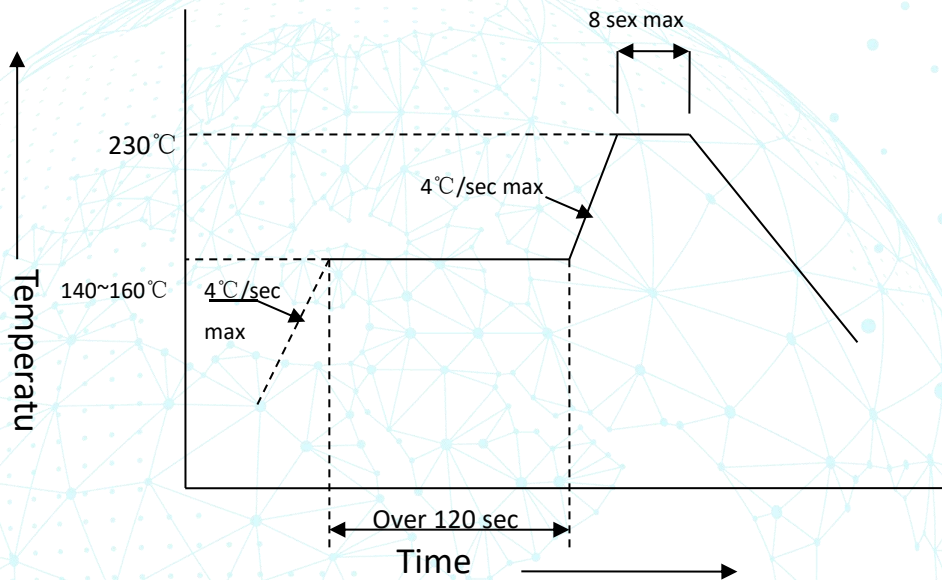

无铅回焊 Lead-Free Solder

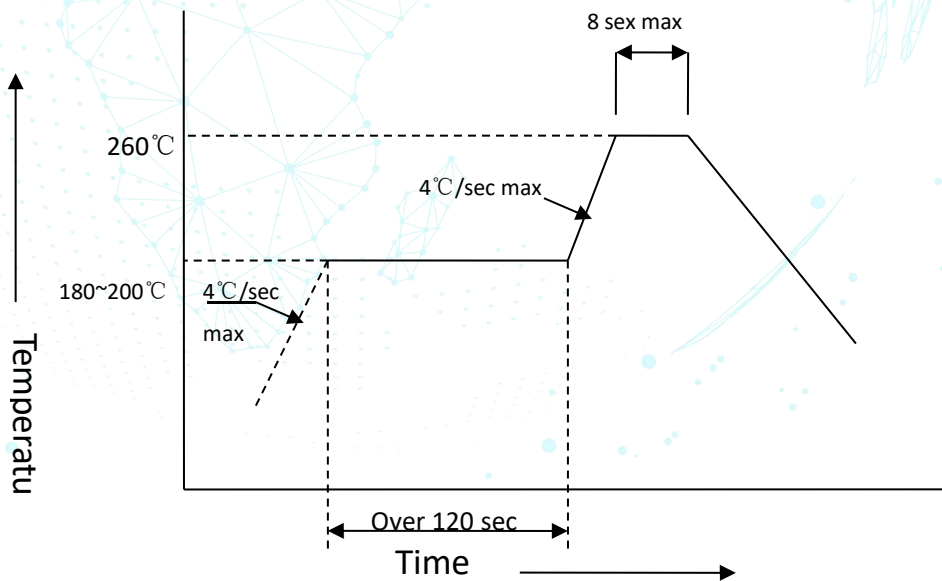

包装 Packing

载带规格 (单位: mm) Tape Specifications (Units : mm)

Packing unit 2004PCS/reel

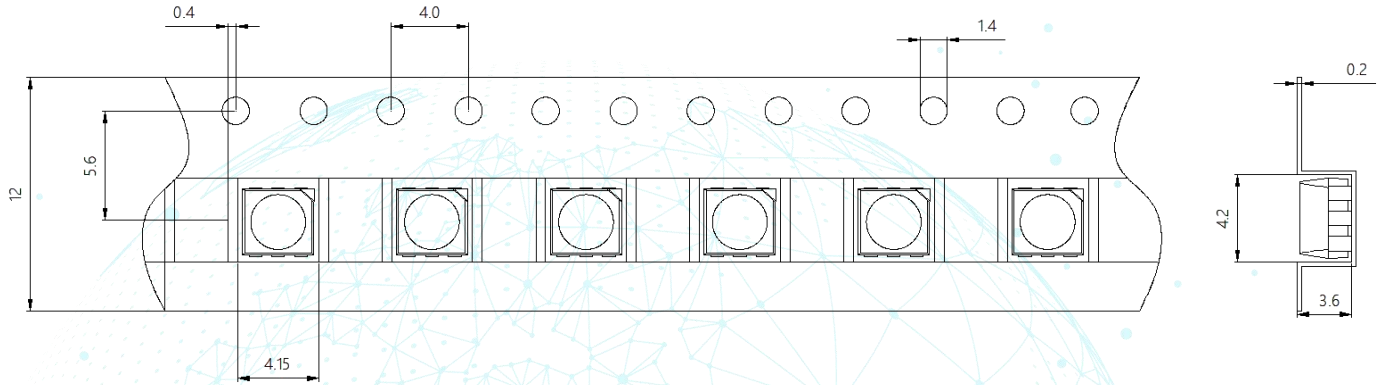

Adhesion Strength of Cover Tape : Adhesion strength to be 0.1 – 0.7N when the cover tape is turned off from the carrier at 10° angle to be the carrier tape. (盖带力度: 当盖带与载带成10度角时力度为0.1 – 0.7N)

卷轴尺寸 Reel Dimensions

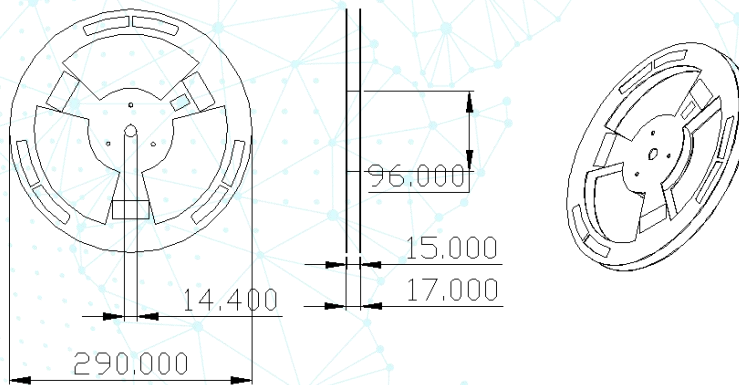

防潮带包装 Moisture Resistant Packaging

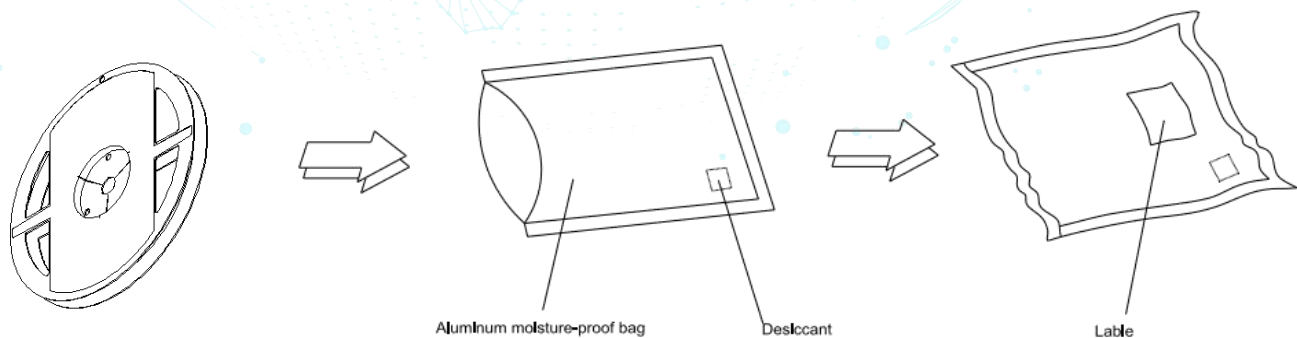

SMD 贴片灯珠使用操作说明

致：尊敬的合作伙伴！

感谢贵司一直以来对我司的信任与支持。为了增进您对我公司的产品特性的了解，方便您在使用过程中掌握其使用特性，尽量减少或避免因人为因素造成不必要的产品损坏或者性能不匹配。特在此说明。

一 物料确认

请先检查包装是否漏气，是否有其他破损，检查标签是否与贵司的要求吻合。若发现异常请及时联系我司。

二 未开包的灯珠存放

未开包的灯珠尽量不要长期存放，由于存放环境不易控制。可以根据订单选择近期交货。存放的环境最好选择防潮柜，温度在 0-30 度左右，60%以内湿度,这种情况下 RGB 产品可以存放 30 天，白光产品可以存放 60 天。

无论存放时间是否超期，生产前请务必进行首件测试。如果发现问题请第一时间联系我们。

三 开包装后的预防措施

收到我司灯珠后，请尽快安排生产，由于各家仓库存储环境不同，不建议做大批量的备库存货，开包后请在 24 小时内将产品用完。

四 不建议将不同批次灯珠进行混用：

生产前按照首检标准进行测试，如果发现灯珠出现异常请联系我司。贵司在生产过程中请不要把不同批次的灯珠混在一起使用。如果避免不了，需要使用上个批次的灯珠，请先确认包装是否正常，再做首件确认。最后将此批灯珠生产的产品进行单独区分。

五 不建议对拆包后的灯珠进行存储，请准确计算好产线的需求量。如果需要存储，建议使用 60 度烤箱存放。

六 贵司在生产过程中，贴片完成后请及时过回流焊，并且不可重复性回流焊接，我司灯珠最多只过一次回流焊。在焊接以及组装过程请检查静电防护措施是否到位。

七 户外使用的灯珠，成品设计尽量采用盖透镜，然后灌封胶密封。不建议直接在灯珠表面封胶。灌封胶尽量选择透气透氧率较低，对铝材粘接性较好的胶水。控制器的负压要降到最低。

八 户外已经安装的成品灯具，在调试完成后，如果不能及时使用的，请注意要进行定时老化，老化前期请用小电流将所有芯片点亮，不要进行扫描程序。老化两小时后将电流逐渐放大，不要扫描程序，进行常亮老化 4 小时。每月一次。在使用初期，请将控制器的速度调到最慢，颜色转换速度最慢。

SMD LED Instruction Manual

Dear partners!

Thank you for your trust and support to our company. In order to enhance your understanding of the product characteristics of our company, it is convenient for you to grasp the characteristics of its use during use, to minimize or avoid unnecessary product damage or performance mismatch caused by human factors. Specifically here.

1. Material confirmation

Please check the package for leaks, other damage, and check if the label matches your company's requirements. If you find an abnormality, please contact us in time.

2. Unopened smd led storage

The unopened smd led should not be stored for a long time as much as possible, because the storage environment is not easy to control. You can choose a recent delivery based on your order. The storage environment is best to choose moisture-proof cabinet, the temperature is about 30 degrees, the humidity is below 60%, in this case RGB products can be stored for 30 days, white light products can be stored for 60 days.

Regardless of whether the storage time is exceeded or not, be sure to perform the first test before production. If you find a problem, please contact us as soon as possible.

3. Precautions after unpacking

After receiving the smd led of our company, please arrange the production as soon as possible. Due to the different storage environments of each warehouse, it is not recommended to make large quantities of stocks. Please use up the product within 24 hours after opening the package. It is recommended to perform 60 degree low temperature baking for 12-24 hours before use.

4. It is not recommended to mix different batches of smd led

Test before the production according to the first inspection standard. If you find any abnormality in the smd led, please contact us. Please do not mix different batches of smd led during the production process. If you can't avoid it, you need to use the leds of the previous batch. Please confirm the package is normal, and then confirm the first piece. Finally, the products produced by this batch of smd led are separately distinguished.

5. It is not recommended to store the smd led after unpacking. Please accurately calculate the demand for the production line. If storage is required, it is recommended to store in a 60 degree oven.

In the production process, please fill in the reflow soldering after the patch is completed, and the reflow soldering is not repeatable.

6. Reflow soldering. Check the ESD protection measures during soldering and assembly.

7. smd led for outdoor application, the finished product design is to use a cover lens as much as possible, and then potting seal. It is not recommended to seal directly on the surface of the lamp. The potting glue should try to choose a glue with low permeability and oxygen permeability and good adhesion to aluminum. The controller's negative pressure should be minimized.

8. Finished luminaires that have been installed outdoors. If the luminaires cannot be used in time after commissioning, please pay attention to the timing aging. Please use a small current to illuminate all the chips in the early stage of aging. Do not scan the program. After aging for two hours, the current is gradually amplified, do not scan the program, and often aging for 4 hours once a month. In the initial stage of use, please adjust the speed of the controller to the slowest and the color conversion speed is the slowest.

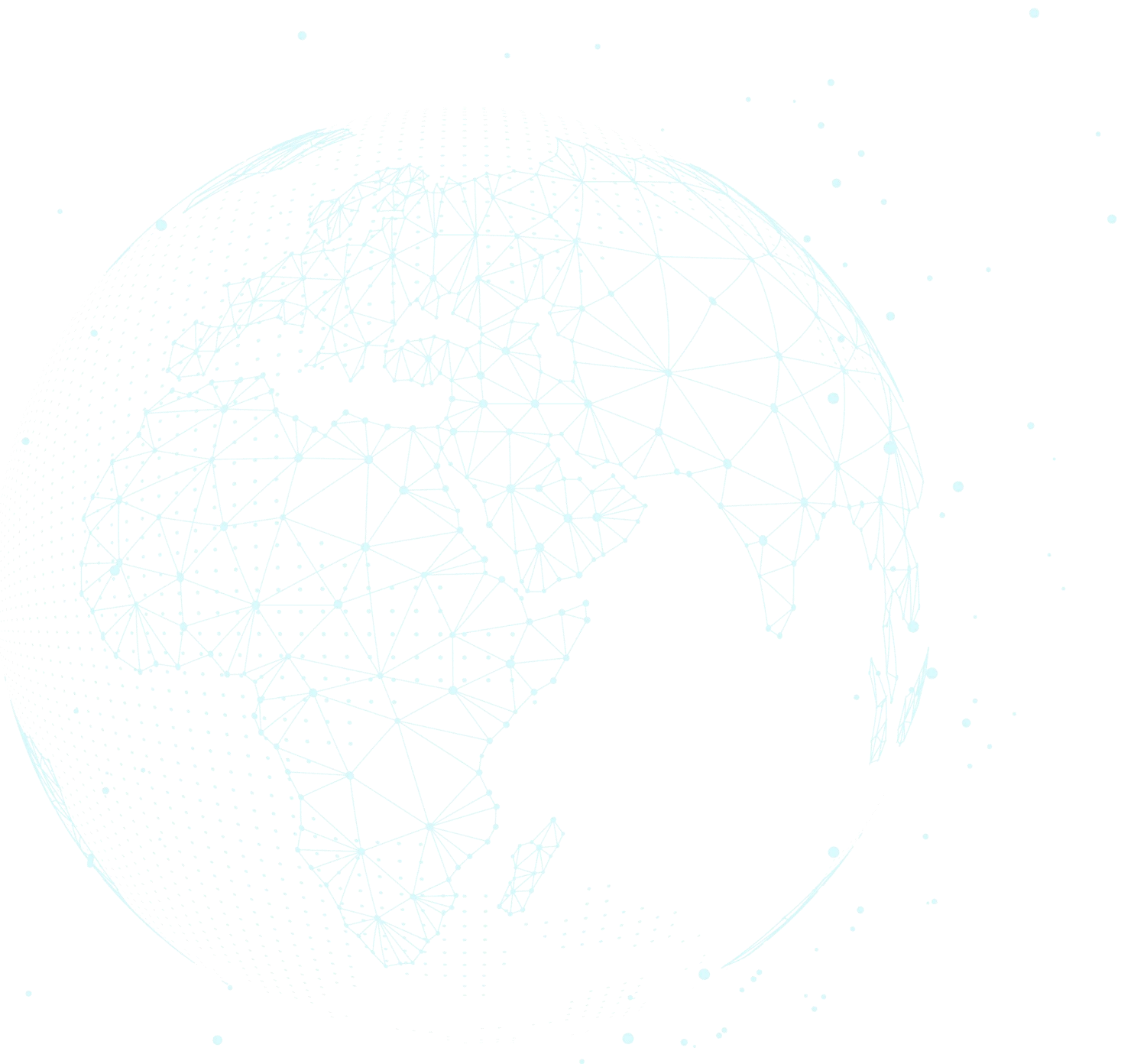

地址：深圳市龙华区福城街道章阁社区大富路35号（硅谷动力深圳市低碳科技示范园A1栋）

电话：(86) 755-2908 9991

传真：(86) 755-2908 9931

WWW.YLLLED.COM

FAX: +86 0755-29089931

Website: www.yuliangled.com

Shenzhen Yuliang Optoelectronic Technology Co.,Ltd