

REV.	DESCRIPTION	DESIGN	APPROVAL	DATE
X2	ADD PACKAGE	Ray Hung	Anchor Deng	2021.07.15
X3	ADD Tape Reel PACKAGE	Ray Hung	Anchor Deng	2021.09.22

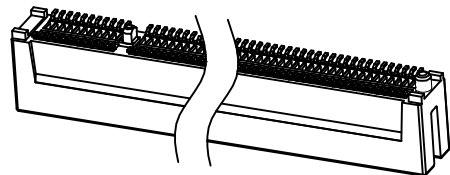
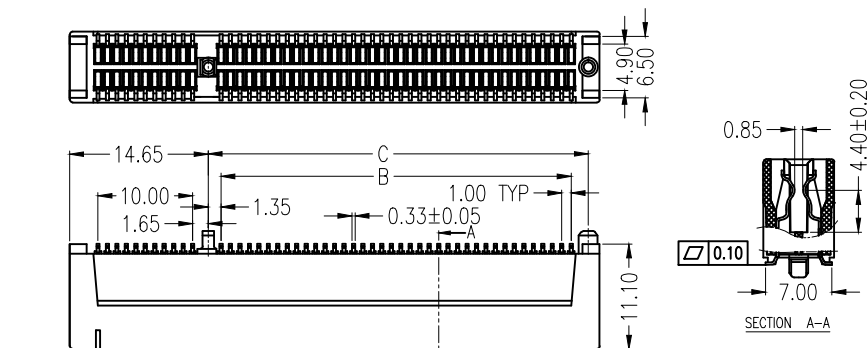

NOTES:

\*Material

Body: LCP, UL 94V-0 Rated.  
 Color: Black  
 Contacts: Phosphor Bronze  
 Plating : Au Plating on Cantact Area,  
 Sn (100u" Min.) plating on solder tail  
 Ni (50u" Min.) underplating overall.

\*Mechanical:

Insertion Force: 1.15N max per contact pair;  
 Withdrawal Force: 0.15N min per contact pair;  
 Contact Retention Force: 3.43N min per contact;  
 Durability: 50 cycles

\*How to order:

PPIE98-LC00-XOF-XH

Number Of Contact:

36:36P 64:64P  
 98:98P

C:Open End Type

Plating:

1: Gold Flash  
 2: Au 15u" MIN.  
 3: Au 30u" MIN.

Package:

7:Tray+Mylar  
 1:Tape Reel

Green code:

H:Halogen Free

\*Electrical Specification

Current Rating : 1.1 Ampere  
 Contact Resistance : 30 mΩ Max.  
 Insulation Resistance : 1000 MΩ Min.  
 Dielectric Withstanding Voltage: 500 VAC

\*Environmental

Operating Temperature: -55°C To +105°C

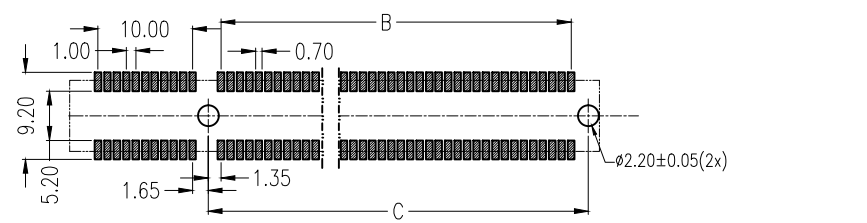
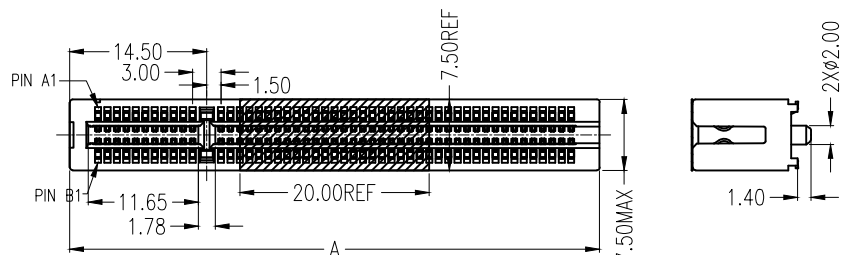

P.C.B LAYOUT(T=1.60mm) COMPONENT SIDE

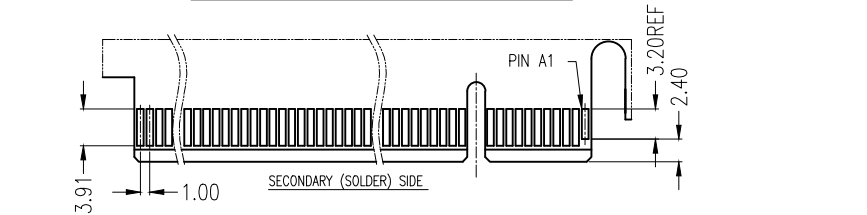

SECONDARY (SOLDER) SIDE

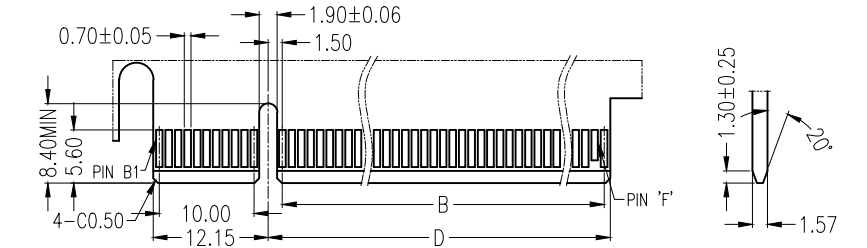

PRIMARY (COMPONENT) SIDE

ADD-IN CARD EDGE-FINGER DIMENSIONS DEFAULT TOLERANCE ±0.13

#POS REF	DIM'A'	DIM'B'	DIM'C'	DIM'D'	PIN'F'
36P	25.00	6.00	9.15	8.15	B17
64P	39.00	20.00	23.15	22.15	B31
98P	56.00	37.00	40.15	39.15	B48

X.± 0.5	X.°± 2°
.X± 0.35	.X°± 1°
.XX± 0.25	.XX°± /
.XXX± 0.15	.XXX°± /
UNITS:	mm

PART NO.	PPIE98-LC00-x0F-xH
TITLE:	PCI Express 4.0 SMT Type (Open End Type)
APPD:	Anchor Deng
CHKD:	Ray Hung
DRAW:	Ray Hung

LUXSHARETECH		
SUPPLIER P/N: XXXX		
DWG NO: PPIE98-LC00-x0F-xH		
SCALE	SHEET	REV.
NONE	1/3	X3

THESE DRAWINGS AND SPECIFICATIONS ARE THE PROPERTY OF LUXSHARETECH AND SHALL NOT BE REPRODUCED, COPIED OR CUED IN ANY MANNER WITHOUT THE PRIOR WRITTEN CONSENT OF LUXSHARETECH

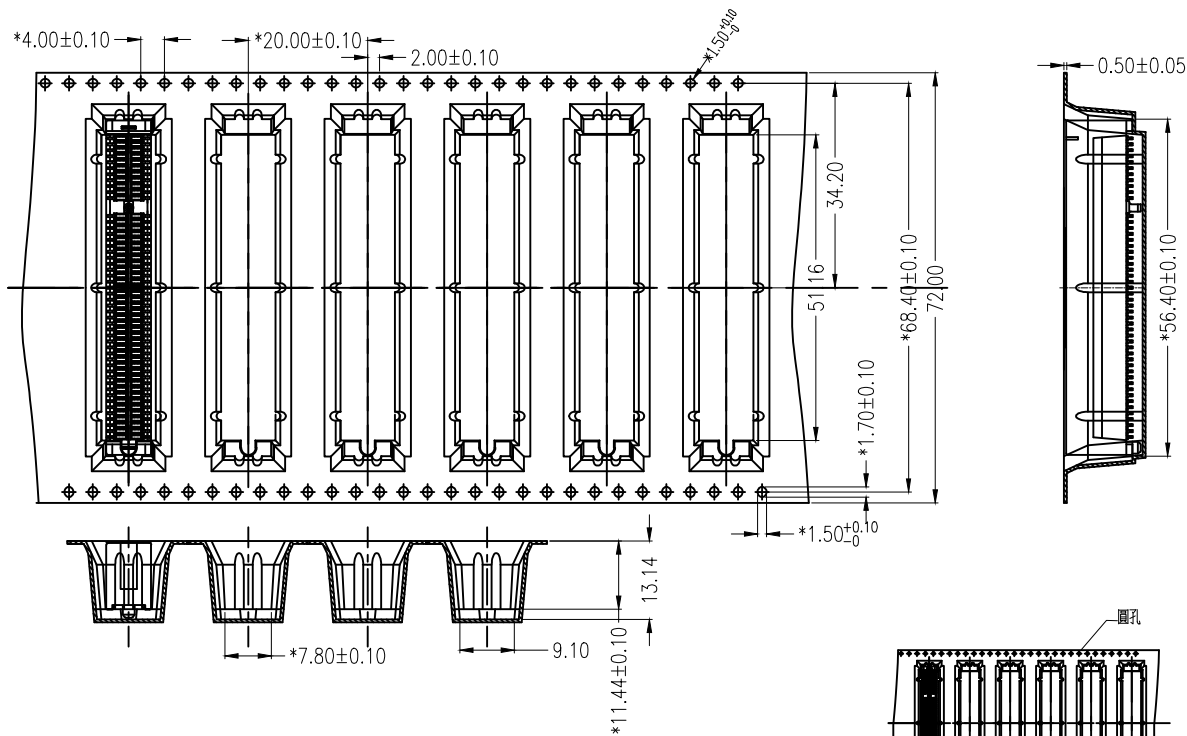

- 附注: 1. 材質: PS (透明色不導電);  
 2. 卷盤顏色: 藍色(φ330mm);  
 3. 單卷可裝長度: 4.6M±0.005M;  
 4. 單卷可裝產品: 230PCS;  
 5. 脫模斜度: 1-3°;  
 6. 圖示中標\* 號檢測點請嚴格管控。  
 7. 上排列孔十個孔距離累計允許公差±0.20mm

REEL 帶來料方向檢驗:  
 豎直放置膠盤, 將載帶右往左拉出, 俯視載帶; 如擺放方向上圖所示, 則來料方向OK; 如與上圖相反, 則來料方向NG。

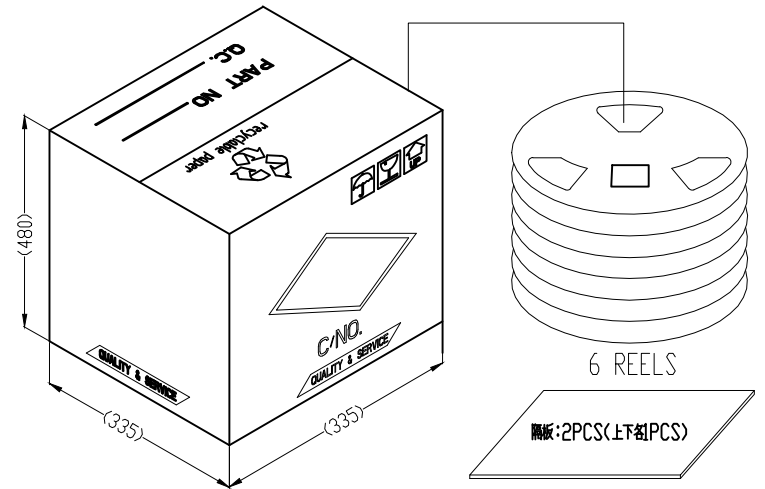
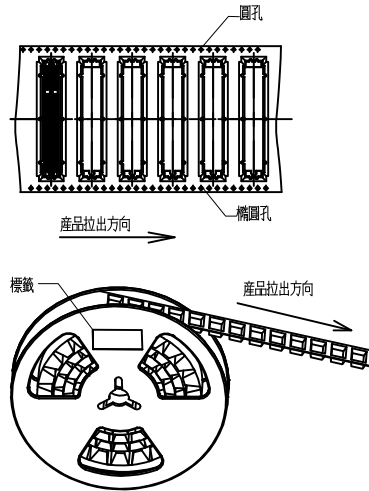

- 注: 1. 成品組裝完成並QC完之後, 將其裝入透明承載帶內, 同時用壓敏膠帶冷封。  
 2. 檢查REEL 包裝卷帶是否有鬆動, 如有鬆動, 需重新貼緊。  
 3. 全檢OK後, 將Reel 盤裝入PE 袋, FQC 復檢。  
 4. 若包裝易吸濕產品在PE 袋內加放1 包干燥劑, 外箱貼易吸濕標籤  
 5. 每一REEL 卷盤上都要貼上料號及蓋印本廠D/C 和數量, 若有特殊要求請貼上客戶料號等。  
 標籤貼在橢圓孔的一邊, 每一REEL 卷盤上都要在標籤上蓋印D/C, 特別注明  
 ① 產品上有噴D/C, 則不需蓋印本廠D/C。 ② 客戶標籤上含蓋有D/C 的, 不需蓋印本廠D/C。  
 6. 產品裝好REEL 出貨時, 拉出端和卷入端各空15PCS 不放產品。

類型	材質	規格(Unit:mm)	數量
外箱	A=A	335*335*480	1PCS
隔板	A IA	332*332*3	2PCS
旋轉膠盤	PC	φ330*φ100	6PCS
承載膠帶	PS(透明)	72(W)*4600(L)*0.50(T)	6PCS
壓敏膠帶	PET	65.5(W)*4600(L)*0.05(T)	27.9m/箱
PE袋	PE	600(開口)*1000*0.065	1PCS

\*PACKING  
 200 PCS/REEL  
 6 REELS/CARTON(共計1200pcs)  
 \*PACKING DETAILS  
 P/O.ND:  
 Q'TY: 1200 PCS  
 N.W.: 5.50 KGS  
 G.W.: 8.80 KGS  
 MEAS: 33.5\*33.5\*48.0 CM

X.± 0.5	X.°± 2°
.X± 0.35	.X°± 1°
.XX± 0.25	.XX°± /
.XXX± 0.15	.XXX°± /
UNITS:	mm
THESE DRAWINGS AND SPECIFICATIONS ARE THE PROPERTY OF LUXSHARETECH AND SHALL NOT BE REPRODUCED, COPIED OR CUED IN ANY MANNER WITHOUT THE PRIOR WRITTEN CONSENT OF LUXSHARETECH	

PART NO.	SEE SHEET 1	LUXSHARETECH			
TITLE:	PCI Express 4.0 SMT Type (Open End Type)	SUPPLIER P/N: XXXX			
APPD:	Anchor Deng	DWG NO: SEE SHEET 1			
CHKD:	Ray Hung		SCALE	SHEET	REV.
DRAW:	Ray Hung		NONE	2/3	X3

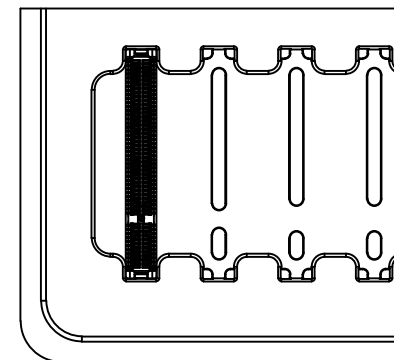
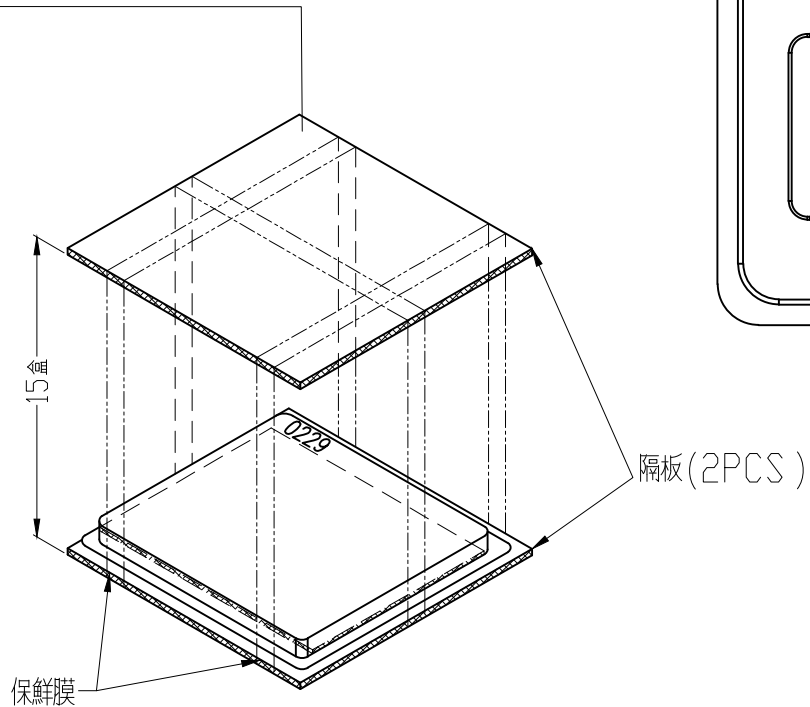
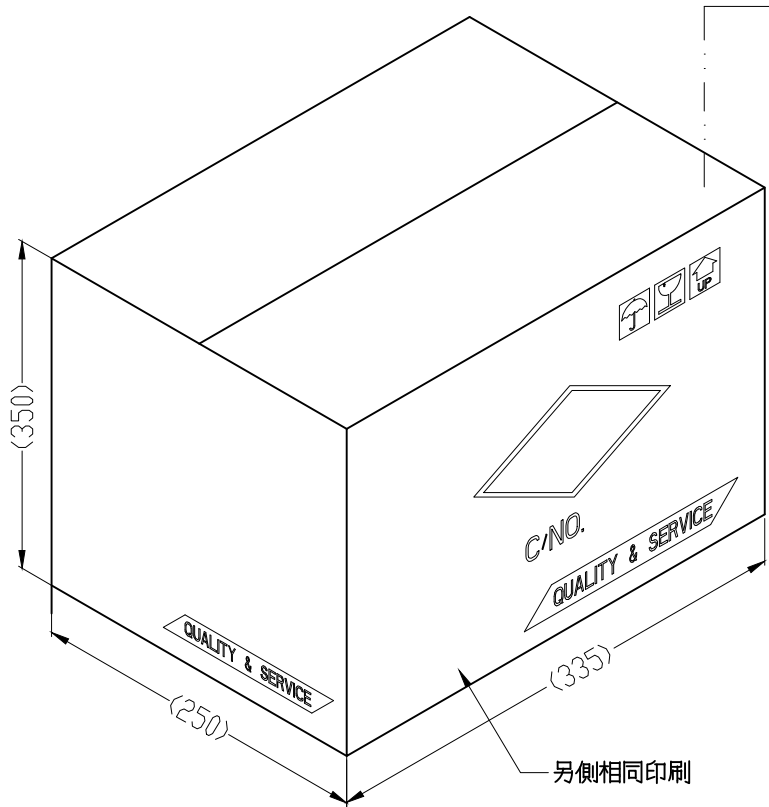

產品擺放示意圖

隔板(2PCS)

保鮮膜

20TRAYS/900PCS/CARTON

材質及尺寸說明

1. 外箱 A=A<雙浪型>
2. 真空盒: PET, 透明色
3. 隔板尺寸: 330\*245\*3.0mm, A1A
4. PE 袋尺寸: 700\*650(開口)\*0.05

1. 每盒裝45pcs 產品, 每箱20 盒真空盒上/下蓋正常疊層放置, 上下各放一個隔板, 用保鮮膜從四面包紮好, 並套上PE 袋后封口
2. 若包裝易吸濕產品在PE 袋內加放1 包干燥劑, 外箱貼易吸濕標籤

PACKING DETAILS

Q'TY: 900 PCS

N.W.: 4.17 KGS

G.W.: 8.24 KGS

MEAS: 33.5X25.0X35.0CM

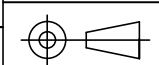
X $\pm$ 0.5	X° $\pm$ 2°	PART NO.	LUXSHARETECH			
.X $\pm$ 0.35	.X° $\pm$ 1°					SEE SHEET 1
.XX $\pm$ 0.25	.XX° $\pm$ /	TITLE: PCI Express 4.0 SMT Type (Open End Type)	SUPPLIER P/N: XXXX			
.XXX $\pm$ 0.15	.XXX° $\pm$ /					
UNITS:	mm	APPD: Anchor Deng	DWG NO: SEE SHEET 1			
THESE DRAWINGS AND SPECIFICATIONS ARE THE PROPERTY OF LUXSHARETECH AND SHALL NOT BE REPRODUCED, COPIED OR CUED IN ANY MANNER WITHOUT THE PRIOR WRITTEN CONSENT OF LUXSHARETECH		CHKD: Ray Hung				
		DRAW: Ray Hung		SCALE	SHEET	REV.
		NONE		3/3	X3	