

Mechanical

NO.	ECN NO.	DESCRIPTION	REV.	DRAW	DATE
1					
2					
3					

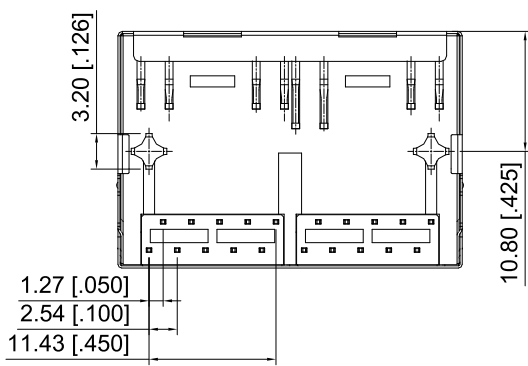
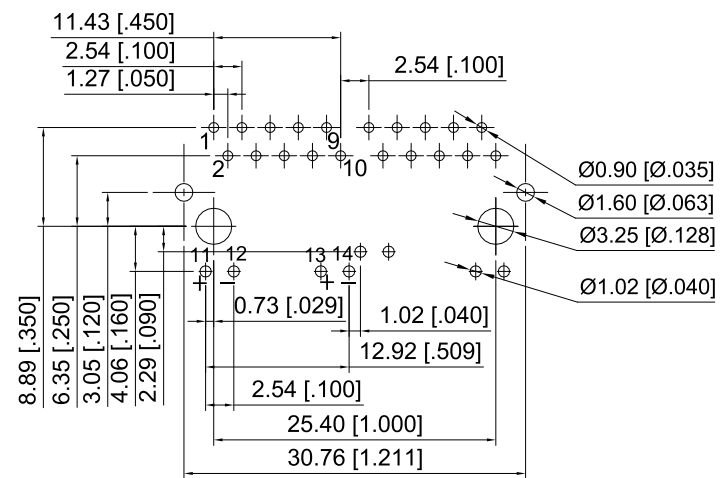
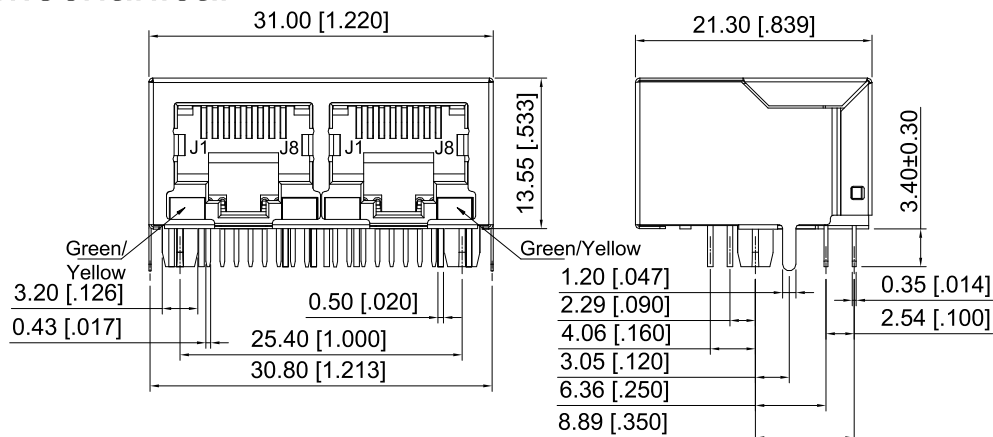

GoldPlating	Option
GF	<input type="checkbox"/>
3μ"	<input type="checkbox"/>
6μ"	<input type="checkbox"/>
15μ"	<input type="checkbox"/>
30μ"	<input checked="" type="checkbox"/>
50μ"	<input type="checkbox"/>

RECOMMENDED P.C.B LAYOUT
TOP VIEW (COMPONENT SIDE)

Dimensions Tolerance:
All PCB LAYOUT
Tolerances:±0.05[.002]

MATERIALS

1.HOUSING:GLASS FILLED PA46(BLACK) UL94V-0(ROHS)
2.CONTACT: PHOSPHOR BRONZE,50 MICROINCHES MIN. OVERALL DUCTILE NICKEL UNDERPLATE WITH SELECTED 30U" GOLD AT MATING INTERFACE
3.SHIELD:0.2mm THICKNESS WITH BRASS.
4.JACK CAVITY CONFORMS TO FCC RULES AND REGULATIONS PART 68 SUBPART F
5.THE PART IS RECOMMENDED FOR WAVE SOLDERING PROCESS PEAK SOLDERING TEMPERATURE IS 260°C MAX,10 SECS MAX.
6.OPERATING TEMPERATURE:-40°C TO +85°C. STORAGE TEMPERATURE:-40°C TO +85°C.

产品客户图 Customer Drw		GLGNET® 深圳市方向电子股份有限公司 SHEN ZHEN GLGNET ELECTRONICS CO.,LTD.	
未注公差 TOLERANCE UNLESS OTHERWISE SPECIFIED	0.XX ±0.10 X.XX ±0.25 XX.XX ±0.25 X° ±2°	Description	RJ45 1X2 Tab_Down/Through Hole 10/100/1000Base-T W/LED
比例 SCALE	1:1	设计 DESIGN	WANGKG 2023.08.01
张数 SHEET	1/2	角法 PROJ.	品名 TITLE
单位 UNIT	mm	大小 SIZE	A4
		校对 CHECKED	DANNY 2023.08.01
		版本 REV.	A0
		核准 APPROVED	BYANG 2023.08.01
		料号 ITEM NO.	JLFJA2S85KW-D1/D1P
		图号 DWG NO.	

Schematic

NO.	ECN NO.	DESCRIPTION	REV.	DRAW	DATE
1					
2					
3					

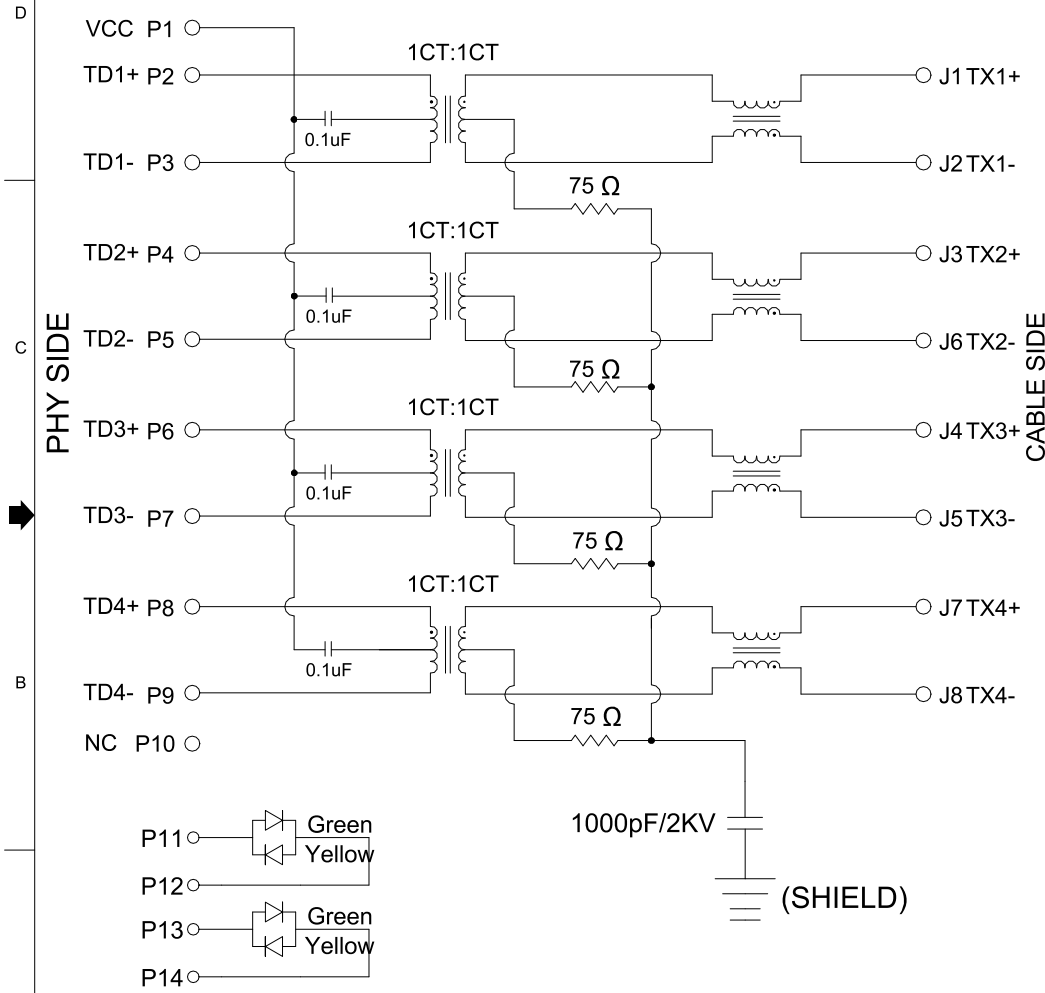

PARAMETER	SPECIFICATIONS
OPERATING TEMPERATURE	-40°C To +85°C
TURNS RATIO	1:1±2%
INDUCTANCE(OCL)	350uH MIN@100KHz/100mV With 8mA DC Bias
INSERTION LOSS	-1.0dB MAX@0.3MHz-100MHz;
RETURN LOSS (Z out=100 OHM)	-18dB MIN@1MHz-30MHz; -16dB MIN@30MHz-60MHz; -12dB MIN@60MHz-80MHz; -10dB MIN@80MHz-100MHz;
CROSSTALK (ADJACENT CHANNELS)	-30dB MIN@1MHz-100MHz;
COMMON MODE REJECTION RATIO	-30dB MIN@1MHz-100MHz;
HI-POT	2250 VDC@60 SECONDS

LED SPECIFICATION			
STANDARD LED	WAVELENGTH	Farward V(max)	TYP
GREEN	570nm	2.4V	2.2V
YELLOW	590nm	2.5V	2.1V

*WITH A FORWARD CURRENT OF 20mA

产品客户图 Customer Drw		GLGNET® 深圳市方向电子股份有限公司 SHEN ZHEN GLGNET ELECTRONICS CO., LTD.				
未注公差 TOLERANCE UNLESS OTHERWISE SPECIFIED	0.XX ±0.10 X.XX ±0.25 XX.XX ±0.25 X° ±2°	Description	RJ45 1X2 Tab_Down/Through Hole 10/100/1000Base-T W/LED			
比例 SCALE	1:1	角法 PROJ.	设计 DESIGN	WANGKG 2023.08.01	品名 TITLE	JLFJA2S85KW-D1/D1P
张数 SHEET	2/2	大小 SIZE	校对 CHECKED	DANNY 2023.08.01	料号 ITEM NO.	
单位 UNIT	mm	版本 REV.	核准 APPROVED	BYANG 2023.08.01	图号 DWG NO.	