

# Schematic

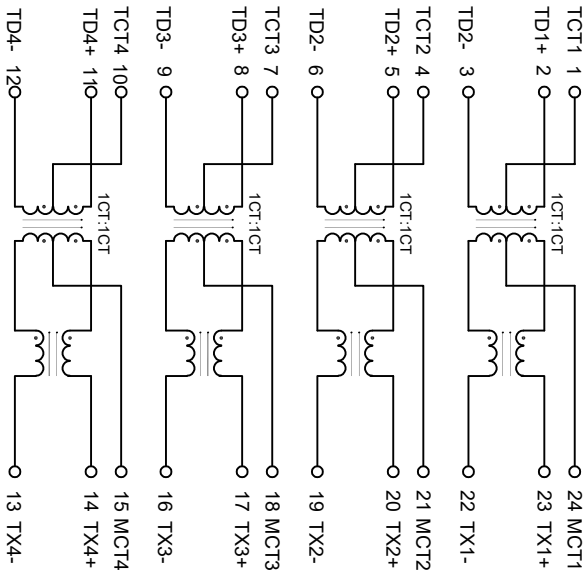

# Mechanical

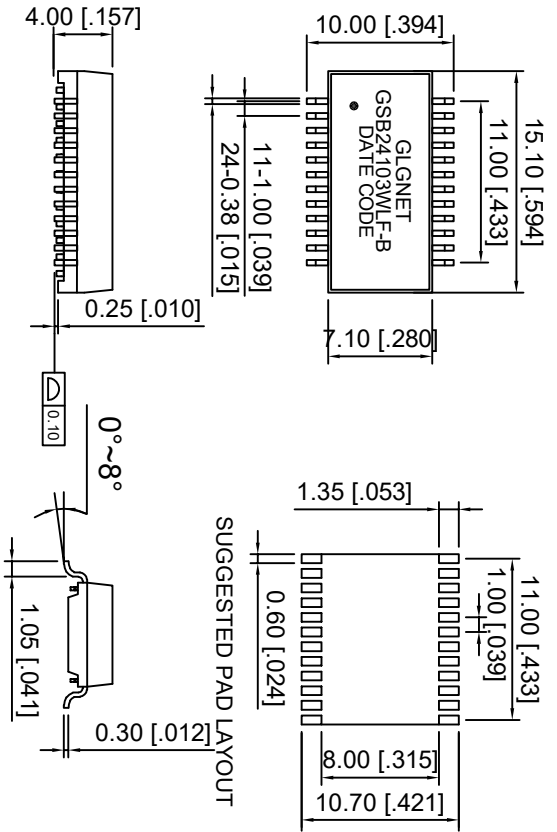

NO.	ECN NO.	DESCRIPTION	REV.	DRAW	DATE
1		与实物相符	A1	聂豪	2022/08/13
2					
3					

PARAMETER	SPECIFICATIONS
OPERATING TEMPERATURE	-40°C To +85°C
STORAGE TEMPERATURE	-40°C To +85°C
TURNS RATIO	1:1±5%
OPEN CIRCUIT INDUCTANCE(OCL)	350uH MIN@100KHz/100mV With 8mA DC Bias For (CHANNEL 1,2,3,4)
INSERTION LOSS(IL)	-1.0dB MAX@1MHz-100MHz;
RETURN LOSS(RL) (Z out=100 OHM)	-18dB MIN@1MHz-30MHz; -16dB MIN@30-60MHz; -12dB MIN@60-80MHz; -10dB MIN@80MHz-100MHz;
CROSSTALK (ADJACENT CHANNELS) (DCMR)	-30dB MIN@1-100MHz; -40dB MIN@30MHz; -35dB MIN@60MHz; -30dB MIN@100MHz;
HI-POT	1500Vrms
STANDARD	Designed to meet IEEE802.3ab & 802.3at Requirement

产品客户图	Customer Dwg	设计	Jack-Nie	品名	GSB24103WLF-B
未注公差	0.XX ±0.10	检对	Checked	料号	ITEM NO.
公差	X.XX ±0.25	设计	Jack-Nie	图号	DWG NO.
UNLESS OTHERWISE SPECIFIED	XX.XX ±0.25	PROJ.	2022.8.13		
	X° ±2°	角法	2022.8.13		
比例	1:1	大小	A4		
张数	1/1	版本	A1		
SHEET	大小	核准	BLUSE BAI		
单位	mm	APPROVED	2022.8.13		

**GLGNET**

GLGNET ELECTRONICS

1000BASE-T Ethernet Isolation Transformer  
24PIN POE 30W SMD PROFILE PACKAGE