

REV.	ECN NO./DESCRIPTION	DATE
F	R210056	08/16"21
G	R210056	08/31"21
H	R210056	10/26"22

NOTES:

- MATERIAL:
HOUSING:HIGH TEMPERATURE THERMOPLASTIC(SEE TABLE)
TERMINAL: PHOSPHOR BRONZE C5191,T=0.25mm;
HOOK: S50C,T=0.30mm
- FINISH:
TERMINAL: 50u" NI PLATING OVER ALL;
100u" MATTE Sn PLATING ON SOLDER TAIL;
GOLD PLATING ON CONTACT AREA.
HOOK: Ni 50u" MIN. UNDERPLATED OVER ALL.
MATTE Sn 100u" MIN. PLATED ON SOLDER AREA.
- MECHANICAL SPEC:
DURABILITY : 50 MATING CYCLES.
RETENTION FORCE : 0.40 kgf MIN PER PIN.
MATING FORCE : 1.15N MAX PER PAIR.
UNMATING FORCE : 0.15N MIN PER PAIR.
- ELECTRICAL SPEC:
CURRENT RATING: 1.1A.
CONTACT RESISTANCE: 30 MILLIOHMS MAX. INITIAL.
INSULATION RESISTANCE: 1000 MEGOHMS MIN.
DIELECTRIC WITHSTANDING VOLTAGE: 500V AC MIN.
- IR REFLOW:
THE TEMPERATURE SHALL BE 260°C MAINTAINING 10 SECONDS
- RoHS COMPLIANT OR HALOGEN FREE COMPLIANT.
- RECOMMENDED STENCIL THICKNESS: 0.18mm.
- STORAGE ENVIRONMENT FOR CONNECTOR:
THE MATERIALS SHOULD BE USED IN 72 HOURS AFTER OPENING THE PACKAGE IF NOT USED UP PLEASE RESEAL AGAIN.IF NOT RESEAL ON TIME,PLEASE BAKE 100C/4H BEFORE USE.
- PRODUCT NUMBER NOTE:
A PCI **** - * ** *

A:REEL PACKING
 C:TRAY PACKING
 SERIAL NUMBER
 K:RoHS COMPLIANT
 P:HF COMPLIANT
 PCI EXPRESS CODE
 PCI EXPRESS
 FINISHED

GENERAL TOLERANCES UNLESS SPECIFIED		PART NO.	LOTES		
.X ± 0.35	X° ± 3°	SEE TABLE	TITLE 36P PCI EXPRESS 4.0 SMT CONNECTOR SIDE PUSH TYPE		
.XX ± 0.25	.X° ± 2°	APPROVED BY			
.XXX ± 0.15	.XX° ± 1°	MARK 10/26"22			
CUSTOMER DRAWING		CHECKED BY	DWG NO. GAP-APCI0473		
		Yao 10/26"22			
SIZE	UNITS	DRAWN BY	SHEET SCALE REV 1 / 3 1:1 H		
A4	MM[INCH]	XUZONG 10/26"22			

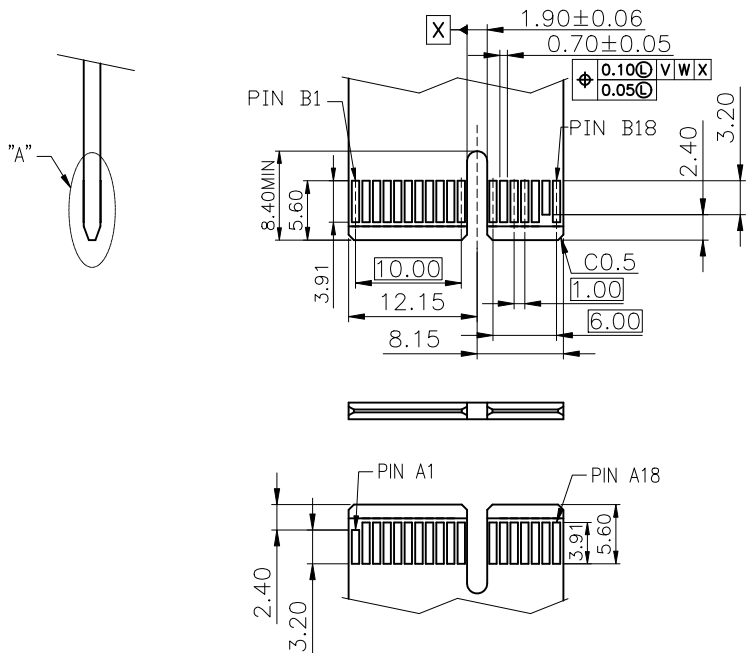

ADD-IN CARD EDGE-FINGER DIMENSIONS

DEFAULT TOLERANCE ±0.05

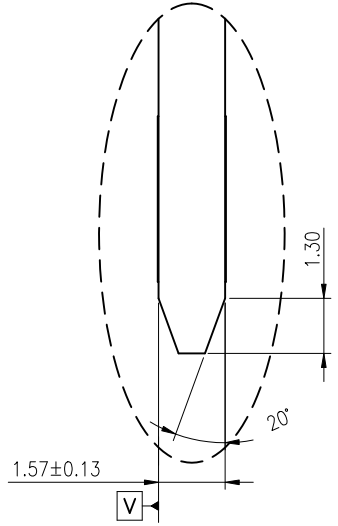

DETAIL "A"
SCALE 4/1

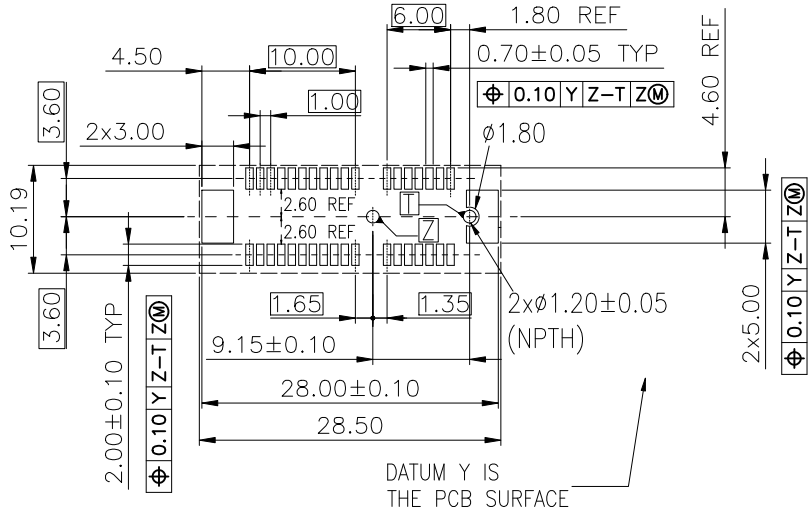

RECOMMENDED FOOTPRINT(TOP VIEW)

DEFAULT TOLERANCE ±0.05

REV.	ECN NO./DESCRIPTION	DATE
F	R210056	08/16"21
G	R210056	08/31"21
H	R210056	10/26"22

GENERAL TOLERANCES UNLESS SPECIFIED		PART NO.	LOTES		
.X ± 0.35	X° ± 3°	SEE TABLE	TITLE 36P PCI EXPRESS 4.0 SMT CONNECTOR SIDE PUSH TYPE		
.XX ± 0.25	.X° ± 2°	APPROVED BY MARK 10/26"22	DWG NO. GAP-APCI0473		
.XXX ± 0.15	.XX° ± 1°	CHECKED BY Yao 10/26"22	DRAWN BY XUZONG 10/26"22		
SIZE A4	UNITS MM[INCH]		SHEET 2 / 3	SCALE 1:1	REV H

REV.	ECN NO./DESCRIPTION	DATE
F	R210056	08/16"21
G	R210056	08/31"21
H	R210056	10/26"22

CAP ASSEMBLY VIEW

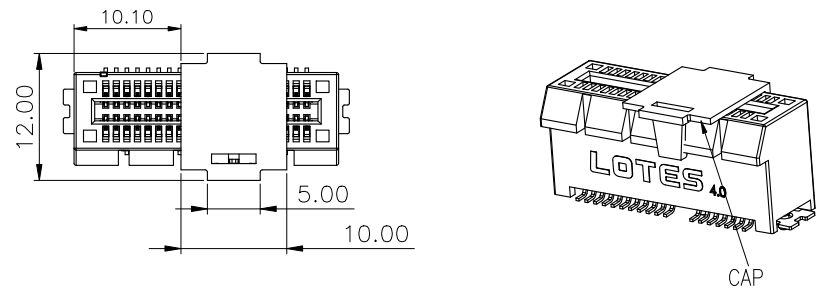

MYLAR ASSEMBLY VIEW

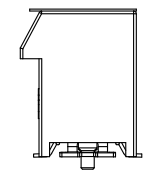
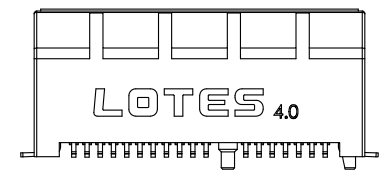
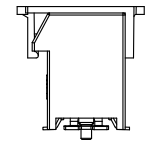
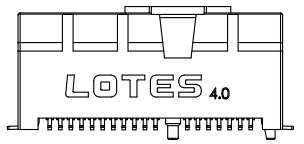
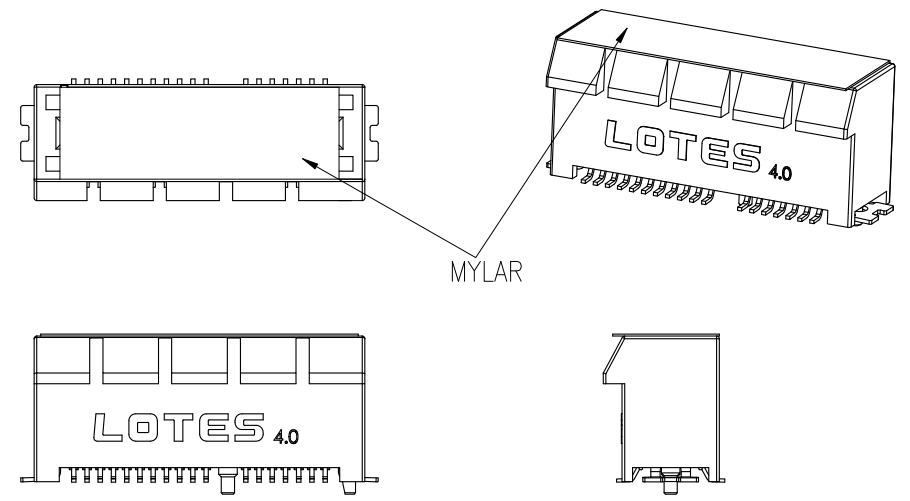

GENERAL TOLERANCES UNLESS SPECIFIED		PART NO. SEE TABLE	LOTES			
.X ± 0.35	X° ± 3°					APPROVED BY MARK 10/26"22
.XX ± 0.25	.X° ± 2°		CHECKED BY Yao 10/26"22	DWG NO. GAP-APCI0473		
.XXX ± 0.15	.XX° ± 1°	CUSTOMER DRAWING		DRAWN BY XUZONG 10/26"22	SHEET 3 / 3	SCALE 1:1
SIZE A4	UNITS MM[INCH]					

PCIE X1 SMT TAP-REEL PACKING VIEW

REV.	ECN NO./DESCRIPTION	DATE
A	R160426	10/27'17
B	R160426	01/23'18

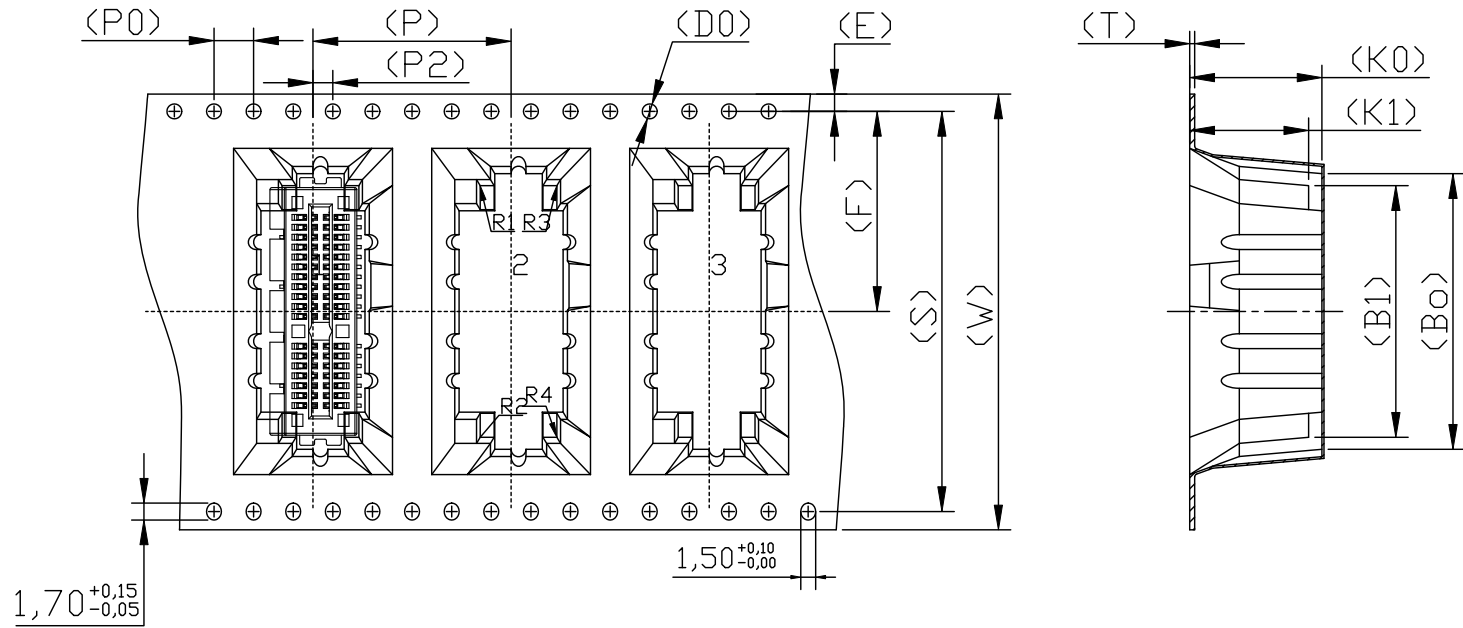

W	44.00±0.30	P	20.00±0.10	A0	10.50±0.15	B0	27.82±0.15
S	40.40±0.10	P0	4.00±0.10	A1	7.75±0.10	B1	25.40±0.10
E	1.75±0.10	P2	2.00±0.15				
F	20.20±0.15	D0	∅1.50 ^{+0.10} ₀	K0	13.35±0.15		
T	0.50±0.05	D1		K1	12.01±0.10		

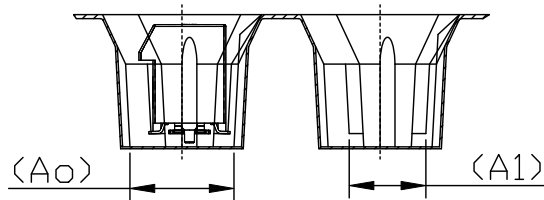

Note:
Material:PS ;W=44;PITCH=20mm;

GENERAL TOLERANCES UNLESS SPECIFIED		PART NO.		LOTES		
.X ± 0.35	X° ± 3°	SEE TABLE				
.XX ± 0.25	X° ± 2°	APPROVED BY Yinjiaxu 01/23'18		DWG NO. GAP-APCI0379		
.XXX ± 0.15	XX° ± 1°	CHECKED BY Mark 01/23'18		DRAWN BY LAWRENCE 01/23'18		
SIZE	UNITS	DRAWN BY LAWRENCE 01/23'18		SHEET	SCALE	REV
A4	MM[INCH]					

PCIE X1 SMT PACKING VIEW

REV.	ECN NO./DESCRIPTION	DATE
A	R160426	10/27'17
B	R160426	01/23'18

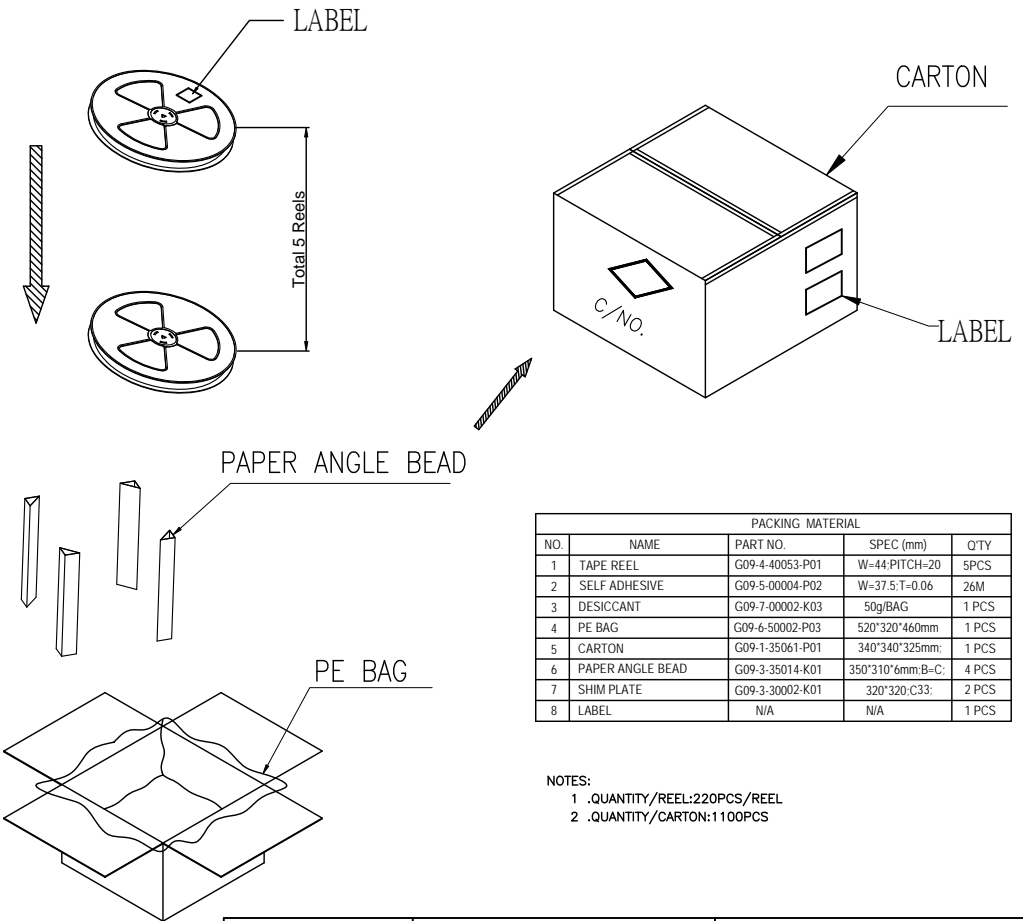
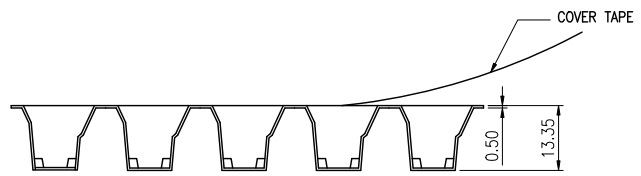
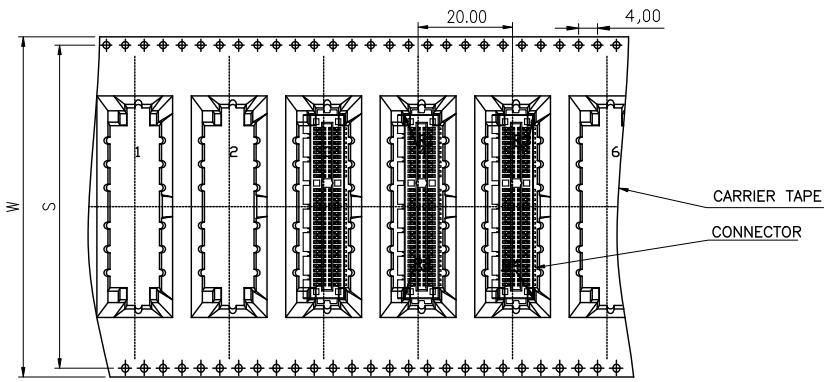
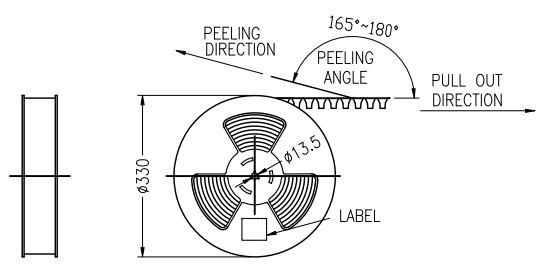
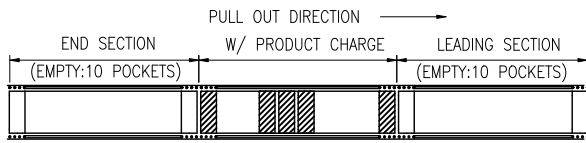

PACKING MATERIAL				
NO.	NAME	PART NO.	SPEC (mm)	Q'TY
1	TAPE REEL	G09-4-40053-P01	W=44,PITCH=20	5PCS
2	SELF ADHESIVE	G09-5-00004-P02	W=37.5,T=0.06	26M
3	DESICCANT	G09-7-00002-K03	50g/BAG	1 PCS
4	PE BAG	G09-6-50002-P03	520*320*460mm	1 PCS
5	CARTON	G09-1-35061-P01	340*340*325mm	1 PCS
6	PAPER ANGLE BEAD	G09-3-35014-K01	350*310*6mm;B=C	4 PCS
7	SHIM PLATE	G09-3-30002-K01	320*320*C33	2 PCS
8	LABEL	N/A	N/A	1 PCS

- NOTES:
 1 .QUANTITY/REEL:220PCS/REEL
 2 .QUANTITY/CARTON:1100PCS

GENERAL TOLERANCES UNLESS SPECIFIED		PART NO. SEE TABLE	LOTES					
.X ± 0.35	X° ± 3°					APPROVED BY Yinjiaxu 01/23'18	TITLE PCI EXPRESS 4.0 SMT PACKING	
.XX ± 0.25	.X° ± 2°							
.XXX ± 0.15	.XX° ± 1°	CHECKED BY Mark 01/23'18	DWG NO. GAP-APCI0379					
CUSTOMER DRAWING		DRAWN BY LAWRENCE 01/23'18	SHEET SCALE REV 2 / 2 1:1 B					
SIZE A4	UNITS MM[INCH]							

TABLE

NO.	PART NUMBER	HOUSING	CAP/MYLAR	TERMINAL	HOOK
1	APCI0473-P001A	HOUSING _BLACK;UL94 V-0	MYLAR	PHOSPHOR BRONZE C5191_30u'Au	S50C
2	APCI0473-P001A01	HOUSING _BLACK;UL94 V-0	MYLAR	PHOSPHOR BRONZE C5191_30u'Au	S50C
3	APCI0473-P001A09	HOUSING _BLACK;UL94 V-0	MYLAR	PHOSPHOR BRONZE C5191_30u'Au	S50C
4	APCI0473-P001A51	HOUSING _BLACK;UL94 V-0	MYLAR	PHOSPHOR BRONZE C5191_30u'Au	S50C
5	APCI0473-P002A	HOUSING _BLACK;UL94 V-0	MYLAR	PHOSPHOR BRONZE C5191_15u'Au	S50C
6	APCI0473-P002A09	HOUSING _BLACK;UL94 V-0	MYLAR	PHOSPHOR BRONZE C5191_15u'Au	S50C
7	APCI0473-P002A51	HOUSING _BLACK;UL94 V-0	MYLAR	PHOSPHOR BRONZE C5191_15u'Au	S50C
8	APCI0473-P003A	HOUSING _BLACK;UL94 V-0	CAP_BLACK;UL94 V-0	PHOSPHOR BRONZE C5191_15u'Au	S50C
9	APCI0473-P003A25	HOUSING _BLACK;UL94 V-0	CAP_BLACK;UL94 V-0	PHOSPHOR BRONZE C5191_15u'Au	S50C
10	APCI0473-P003A34	HOUSING _BLACK;UL94 V-0	CAP_BLACK;UL94 V-0	PHOSPHOR BRONZE C5191_15u'Au	S50C
11	APCI0473-P004A	HOUSING _BLACK;UL94 V-0	CAP_BLACK;UL94 V-0	PHOSPHOR BRONZE C5191_30u'Au	S50C
12	APCI0473-P005A25	HOUSING _BLACK;UL94 V-0	MYLAR	PHOSPHOR BRONZE C5191_15u'Au	S50C
13	APCI0473-P006A14	HOUSING _BLACK;UL94 V-0	CAP_BLACK;UL94 V-0	PHOSPHOR BRONZE C5191_30u'Au	S50C
14	APCI0473-P010A	HOUSING _BLACK;UL94 V-0	MYLAR	PHOSPHOR BRONZE C5191_1u'Au	S50C
15	APCI0473-P003A11	HOUSING _BLACK;UL94 V-0	CAP_BLACK;UL94 V-0	PHOSPHOR BRONZE C5191_15u'Au	S50C