

# Hybrid Tantalum Capacitor - HTHC2W3 Series

## ◆Features:

1. All tantalum shell, airtight, cylindrical, lead out in the same direction, polarized, 3 screws with 120° angle structure, easy to install.
2. The product is a hybrid capacitor composed of tantalum electrolytic capacitors and electrochemical capacitors, which is small in size and large in energy storage, and is the first innovative product in China.
3. Excellent and stable electrical performance, high reliability, long life, high energy density per unit volume, and larger capacity than THC1W type.
4. In the energy conversion circuit, it can act as a battery, providing the circuit with functions such as energy storage, power-off delay, etc.



## ◆Specifications:

1. Operating Temperature Range: -55°C~ +125°C. For the Derated Design please see guide line on page 2~4
2. Capacitance Tolerance: Q: -10% ~ +30%, K: ± 10%, M: ± 20%
3. Storage temperature:-62°C ~ +130°C

## ◆Electrical Characteristics

**Table 1 Rated Voltage, Category Voltage, Surge Voltage, Nominal Capacitance and Main Features**

Rated Voltage(V)	Category Voltage(V)	Surge Voltage(V)	Nominal Capacitance (µF)	tg δ (%)	ESR (Ω) 1kHz	Leakage Current max(µA)		Impedance max (Ω) 100Hz -55°C	Capacitance Variation(%)		Dimension D X H (mm)	Height of screw h (mm)	Negative pole height h1	Max Weight (g)
						25°C	85°C		55°C	85°C				
50	30	55	24000	70	0.035	400	2400	1.2	-55	135	35.5×16	8±0.5	6±0.5	100
75	45	82.5	3000	20	0.06	200	1200	1.6	-15	30	35.5×10	8±0.5	12min	65
75	45	82.5	10000	40	0.06	500	3000	1.6	-45	95	35.5×16	8±0.5	14±0.5	110
80	40	88	5600	40	0.06	500	3000	1.6	-40	90	35.5×12	6-0.5	6±0.5	78

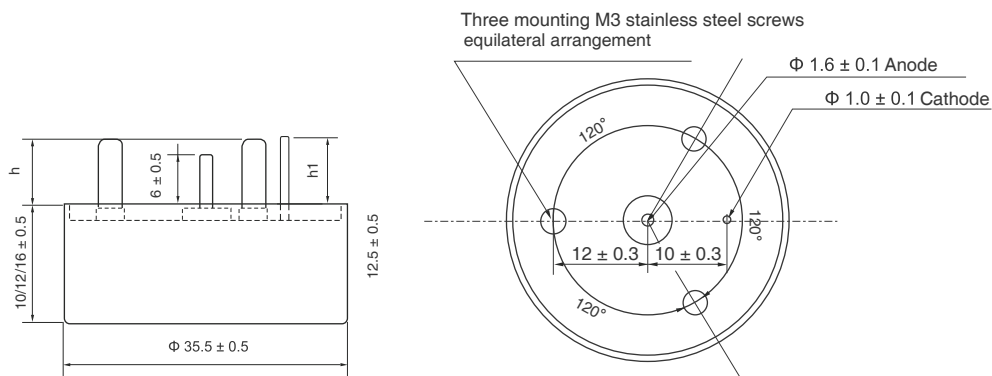

**Figure 1 Outline Structure and Mounting Dimensional Diagram**

- P.S.:
1. It is forbidden to use multimeter to measure tantalum capacitors regardless of polarity
  2. The measuring frequency of capacitance and dissipation factor is 100HZ,  $U = 2.20 - 10v$ ,  $U = 1.0\%_{osv}$  (effective value). The measurement method adopts series equivalent circuit
  3. Apply the derated voltage when measuring leakage current at 125 C, and the leakage current parameter is the 5-minutes reading
  4. Negotiate with our company for production of the products with large capacitance or special size exceeding this standard
  5. The dimensions of this item are all marked in millimetre(mm)

## ◆ Derated Design guide line:

### 1. Derating Recommendations

#### 1.1:

The failure rate of tantalum capacitors is for the DC rating (85°C, rated voltage), and varies with usage conditions (ambient temperature, applied voltage, circuit resistance, etc.). In actual circuits, there are often voltage or current peak impulses and ripple currents, or other unexpected electrical impulses, so derating design is necessary in actual use. Only in this way can the safety and reliability of the circuit be

#### 1.2: Rated voltage and derated voltage

The rated voltage (UR) of tantalum capacitors refers to the maximum DC voltage allowed to be applied to the capacitor at a rated temperature of 85°C. If it is used beyond the rated voltage, the dielectric strength of the dielectric oxide film Ta<sub>2</sub>O<sub>5</sub> will be exceeded, which will lead to deterioration of the capacitor performance, and even dielectric breakdown and failure in severe cases.

The environment in which the actual circuit is used is very complex, so in the circuit design, derating design is generally adopted. According to the "Component Derating Criteria" standard, the derating levels of tantalum capacitors are divided into I, II, and III. Class I derating is derated by 50% of the benchmark DC working voltage, class II derating is derated by 60% of the benchmark DC working voltage, and class III derating is derated by 70% of the benchmark DC working voltage.

When the ambient temperature is not more than 85°C, the derated reference DC working voltage is the rated voltage (Ur); when the ambient temperature is more than 85°C, the derated reference DC working voltage is the derated voltage specified in this manual for each model (Ur). (Uc). In the derating design, non-solid electrolyte tantalum capacitors and conductive polymer electrolyte tantalum capacitors should be derated at least according to level III. When these two types of tantalum capacitors are used in circuits or filter circuits with high reliability requirements, it is recommended that they should be at least level II Derating; solid electrolyte (manganese dioxide) tantalum capacitors are derated at a minimum of 65% of the reference DC working voltage. When this type of tantalum capacitors are used in circuits or filter circuits with high reliability requirements, it is recommended to derate at least according to class I.

Under the conditions allowed by the design, the derating range should be increased as much as possible. For tantalum capacitors, the larger the derating range, the higher the reliability.

### 2. Reverse voltage

#### 2.1:

The rated voltage (UR) of tantalum capacitors refers to the maximum DC voltage allowed to be applied to the capacitor at a rated temperature of 85°C. If it is used beyond the rated voltage, the dielectric strength of the dielectric oxide film Ta<sub>2</sub>O<sub>5</sub> will be exceeded, which will lead to deterioration of the capacitor performance, and even dielectric breakdown and failure in severe cases.

#### 2.2:

In principle, it is forbidden to use a three-meter electrical barrier to test the circuit with tantalum capacitors or the capacitor itself regardless of polarity (it is easy to apply reverse electricity).

#### 2.3:

In the process of measurement and use, if the tantalum capacitor is accidentally applied to the reverse voltage exceeding the specified value. Even if its electrical parameters are still qualified, the capacitor should be scrapped.

Because the quality hidden danger caused by the reverse voltage of the capacitor has a certain latency period, it may not be manifested at that time.



**Table 1 Recommended voltage for various types of products**

Product Type	Series	Recommended voltage	
		-55°C~85°C	85°C~125°C
Non-Solid Electrolyte Tantalum Capacitors (Tantalum Case)	CAK38,CAK39, CAK39H,THC1 etc.	65%U <sub>R</sub>	42%U <sub>R</sub>
Non-solid Electrolyte Tantalum Capacitors (Silver Case)	CAK35,CAK86 etc.	65%U <sub>R</sub>	42%U <sub>R</sub>
MnO. Solid Electrolyte Tantalum Capacitors (Metal Case)	CAK,CAK- 1 etc.	(50%-60%)U <sub>R</sub>	40% U <sub>R</sub>
Polymer Solid Electrolyte Tantalum Capacitors (Metal Case)	CAK66 etc.	(50%-60%)U <sub>R</sub>	40% U <sub>R</sub>
MnO. Chip Type Solid Electrolytic Tantalum Capacitor (Molded Plastic Package)	CAK45,CAK45L, CAK45U,CAK45M etc.	50%U <sub>R</sub>	33%U <sub>R</sub>
Chip Polymer Solid Electrolyte Tantalum Capacitor (Molded Plastic Package)	CAK55,CAK55H etc.	50%U <sub>R</sub>	33% U <sub>R</sub>
MnO. Solid Electrolyte Tantalum Capacitors (Molded Plastic)	CAK44,CAK41 etc.	50%U <sub>R</sub>	33% U <sub>R</sub>

When the circuit adopts all tantalum capacitors above 35V (including 35V), it should be able to withstand the reverse test of the 1.5V power supply of the three-meter, and the 9V power supply should be absolutely prohibited.

**3. Influence factors of failure rate**

**3.1:**

The lower the voltage across the actually added tantalum capacitor is lower than the rated voltage, the lower the failure rate of the tantalum capacitor. The failure rate of tantalum capacitors is evaluated under the maximum allowable load conditions at the rated voltage of 85°C.

**3.2:**

Another factor that affects the failure is the series resistance connected to the outer circuit of the capacitor. The greater the resistance in series with the capacitor in the outer circuit circuit, the lower the failure rate.

Failure rate grade: 2.0%/1000h is expressed as L; 1.0%/1000h is expressed as M; 0.1%/1000h is expressed as P; 0.01%/1000h is expressed as R, 0.001%/1000h is expressed as S.



**Table 2 Reverse voltage resistance of various types of products**

Product Type		Series	Withstand reverse voltage
Non-Solid Electrolyte Tantalum Capacitors	All tantalum capacitors with tantalum case	CAK38, CAK39, CAK38T etc.	Resistant to 3V reverse voltage
	Hybrid Tantalum Capacitors	THC1, THC2, THC1W, CAK36S1, CAK36S1W etc.	Not resistant to reverse voltage
	Silver case	CAK35, CAK35X, CAK86, CAK81 etc.	Not resistant to reverse voltage
Solid Electrolyte Tantalum Capacitors		CAK, CAK-1, CAK-8, GCA, GCA411C etc.	<p>Generally, reverse voltage is not allowed, let alone used in pure AC circuits. If it is unavoidable, it is allowed to apply a reverse voltage not greater than the following in a short period of time, and its value is:</p> <p>below 25°C: <math>\leq 10\% U_R</math> or 1V (whichever is smaller);</p> <p>below 85°C: <math>\leq 5\% U_R</math> or 0.5V (whichever is smaller);</p> <p>below 125°C: <math>\leq 1\% U_R</math> or 0.1V (whichever is smaller).</p> <p>Note: If the capacitor needs to work in a circuit with reverse voltage for a long time, please use a bipolar tantalum capacitor, but it can only be used in a DC or pulsating circuit with a low frequency of polarity change.</p>
Polymer Solid Electrolyte Tantalum Capacitors		CAK66 etc.	Not resistant to reverse voltage
Solid Electrolyte Tantalum Capacitors		CAK44, CAK41 etc.	Not resistant to reverse voltage
Chip Tantalum Solid Electrolyte Tantalum Capacitors		CAK45, CAK45L, CAK45U, CAK45M etc.	Not resistant to reverse voltage
Chip Polymer Solid Electrolyte Tantalum Capacitors		CAK55, CAK55H etc.	Not resistant to reverse voltage

Note: Specification is subject to change without further notice. For more details and updates, please visit our website.