



Jiangmen Hongli Energy Co., Ltd.

Customer acceptance

Lithium Manganese Dioxide Battery

CR2032H

Typed : _____ Date : _____

Checked : _____ Date : _____

Approved: _____ Date : _____

Customer admit signature:

Approved :

Date :

1. Scope

These specifications are applicable to the manganese dioxide lithium batteries supplied by (Jiangmen Hongli Energy Co., Ltd. (Abbreviation: **Holith**) .

2. Applicable Battery Type	Manganese dioxide Lithium Battery
3. Battery Type and Performance	
3.1 Type	CR2032H
3.2 Nominal voltage	3.0 volts
3.3 Nominal discharge capacity	240mAh (Load: 15K ohm, End voltage 2.0V)
3.4 Outside dimensions	As per drawing attached
3.5 Standard weight	2.95g
3.6 Guarantee	1 year (at the temperature of less than 25 deg. C and the relative humidity of less than 75%RH.)
3.7 Appearance	Will be free from flaw, stain, deformation, uneven tone, electrolyte leakage and other defects which impair the value of the commodity.
3.8 Brand	The brand name of "HOLITH" is used.

4. Main reference

Item	Unit	Figures	Condition	
Nominal Voltage	V	3.0	Only appropriated for CR Battery	
Nominal Volume	mAh	240	15k Ω continuously discharge load	
Instantaneous short-cut circuit	mA	≥ 300	time $\leq 0.5'$	
Open circuit Voltage	V	3.25~3.45	All CR Battery series	
Storage temperature	$^{\circ}\text{C}$	0~40	All CR Battery series	
Appropriated temperature	$^{\circ}\text{C}$	-20~60	All CR Battery series	
Standard weight	g	Appro2.95	Only appropriated for this item	
Discharge of life	%/yr	≤ 2	Only appropriated for this item	
Quick Test Use of life	Initial	H	≥ 240.0	Discharge load 3k Ω , Temperature 20 \pm 2 $^{\circ}\text{C}$, under the condition of related humidity $\leq 75\%$
	After 12 months	h	≥ 235.2	

Remark1: The electrochemistry of this product, dimension are under IEC 60086-1: 2007 standard (GB/T8897.1-2008, Battery , Related to 1st part)

5.Specification of product and Test method

Exception for specified explanation, all tests should process under below conditions:

(1) Environment Temperature : Temperature $20\pm 5^{\circ}\text{C}$

(2) related humidity: under $60\%RH\pm 15\%$

Test items	Test Methods	Standard
1. Dimension	Use of caliper under precision is 0.02mm or more precise, to avoid short-circuit, insulated materials should be put on the vernier caliper during test.	diameter (mm): 20.0 (-0.20) height (mm): 3.20 (-0.20)
2. Open circuit voltage	Precision is 0.25% or more precise, resistance of internal circuit is bigger than $1\text{ M}\Omega$ DDM.	3.25-3.45
3. Instantaneous short-circuit	Using pointer multimeter for test, the time is not more than 0.5' , avoid duplicated test, the time for next test should be after half an hours.	$\geq 300\text{mA}$
4. Appearance	Visual test	Will be free from flaw, stain, deformation, uneven tone, electrolyte leakage and other defects. Installed to utensils, both terminal of battery should be under good connections.
5. Quick Discharged Volume	Standard Temperature $20\pm 2^{\circ}\text{C}$, related humidity $\leq 75\%$, discharge load $3\text{k}\Omega$, terminated voltage be 2.0V	≥ 240 hours
6. Vibrate test	Vibrate frequency 100-150 times per min under continuously vibration for 1 hour	Stability
7. High temperature-resistant of weeping performance	Storage 30 days Under 45 ± 2 conditions	leakage $\% \leq 0.0001$
8. Circuit load of weeping performance	When terminated voltage is 2.0V, continuously discharge load for 5hrs	No leakage

Remark2: The bearing boundary dimension of this product, dimension are under IEC 60086-2: 2007 standard (GB/T8897.2-2008, Battery, Related to 2nd part)

Remark3:

1. Above tests were approved under plenty of experiments.

2. The company completely more stringent than the national standard issued by the GB/T8897 《primary batteries》 standards.

3. If necessary or under customer's specified requested, our company can adopt any test methods provided by customers.

6. Service life

Load resistance	15,000 ohms
Discharge method	24 hours/day
End voltage	2.0V
Minimum duration (Initial)	1 2 0 0 hours
Minimum duration (After 12 months storage)	1 1 7 6 hours

Initial test : A test commencing within one month after delivery.

Stored test : A test conducted after 12 months storage under the specified conditions after delivery.

7. Discharge characteristics on load

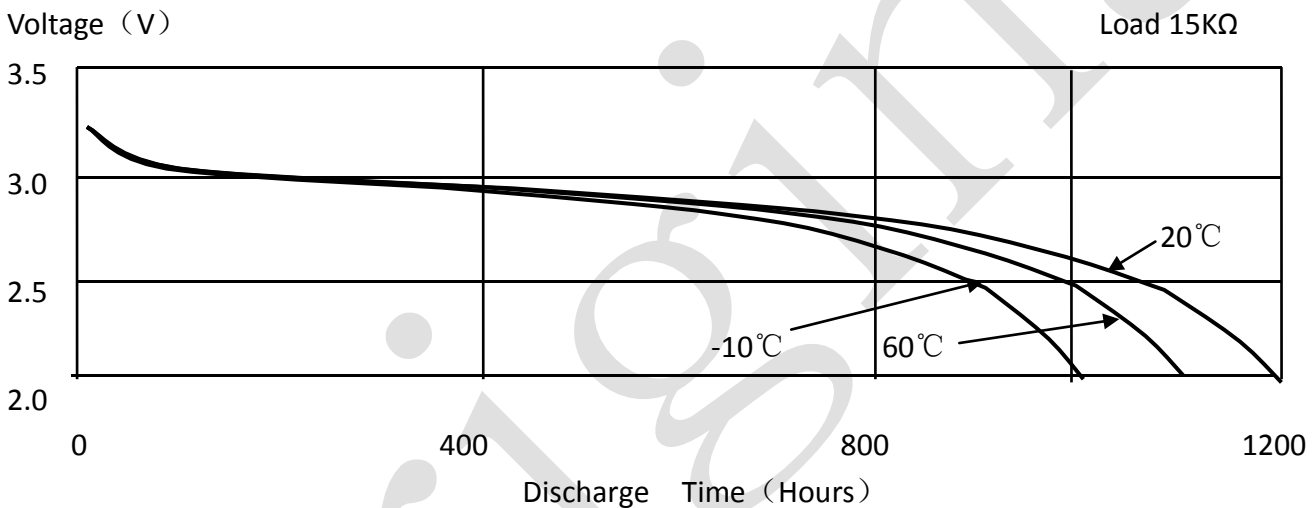

8. Battery Testing

8.1 Temperature and Humidity

8.1.1 Conditions of Measurement

The battery will be measured under the conditions of temperature of $20 \pm 5^\circ\text{C}$ and relative humidity of $65 \pm 15\% \text{RH}$ unless otherwise stated.

8.1.2 Conditions of Storage

The sample batteries for testing will be stocked under the conditions of temperature of less than 25°C and relative humidity of less than 75%.

The test will be carried out within 1 month after storage unless otherwise stated.

Instruments and Devices for Measurement

- 8.2.1 The DC voltmeter will be used to carry out voltage measurement that can measure from 0V to 4V. The accuracy of the voltmeter will be +/-1mV or it will be more accurate. The input impedance will be more than 10M ohm.
- 8.2.2 All the resistance of the external circuit load resistance will be comprised and the tolerance will be within 0.5%.
- 8.2.3 The caliper will be used to conduct dimension measurement and the range for measurement is from 0mm to 150mm. The accuracy is 5/100mm or more.
- 8.3 Testing systems
- 8.3.1 Dimensions
The caliper is used as the instrument for measurement.
- 8.3.2 Appearance
The visual inspection is applied.
- 8.3.3 Open circuit voltage
The DC voltmeter is used to measure the voltage between both terminals
- 8.3.4 Service Life
The battery samples are kept under the condition of temperature of 20+/-5 deg. C for over 12 hours. The battery samples will be discharged persistently through the discharge load mentioned in Table 1. The discharge test will be conducted till the discharge voltage falls down to not less than the final voltage specified in Table 1. The discharge time is the service life while the discharge voltage remains above the final voltage as stated.
- 8.3.5 Resistance of electrolyte leakage
The visual inspection is used for checking the state of the leakage. The battery will be put 30cm away under 40 watt fluorescent lamp at one meter above.

9. Limited warranty

If defective in materials or workmanship is identified, please return the product to HOLITH and the replacement will be delivered without charge.

Please note that the only obligation under this warranty is the replacement of the battery. Other loss, damage, destruction, any legal liabilities, cost or expense including consequential loss of whatsoever nature, directly or indirectly caused by, resulting from or in connection

with use of or inability to use the product are expressly excluded.

- (2) The work on the battery needs to comply with the instructions in this specification; otherwise, HOLITH cannot warrant any battery performance included but not limited to safety and the customer shall be responsible for all claims, demands, loss, damage, actions or proceedings, and costs (legal or otherwise) caused by this battery.
- (3) It is the customer's responsibility for the matching and reliability of batteries on actual set or unit application.
- (4) HOLITH will not be responsible for the following situations:
- (i) Inappropriate handling, use, installation, or examination of the battery.
 - (ii) Do not comply with the instructions, attentions or warnings mentioned in this specification.
 - (iii) Do not comply with the instructions or advice of Jiangmen Hongli Energy Co., Ltd.

10. Others

Subject the RoHS directive, this battery does not contain the following chemical substance: lead, mercury, cadmium, hexavalent chromium, bromic, fire retardants (polybrominated biphenyl (PBB), polybrominated diphenyl (PBDE))

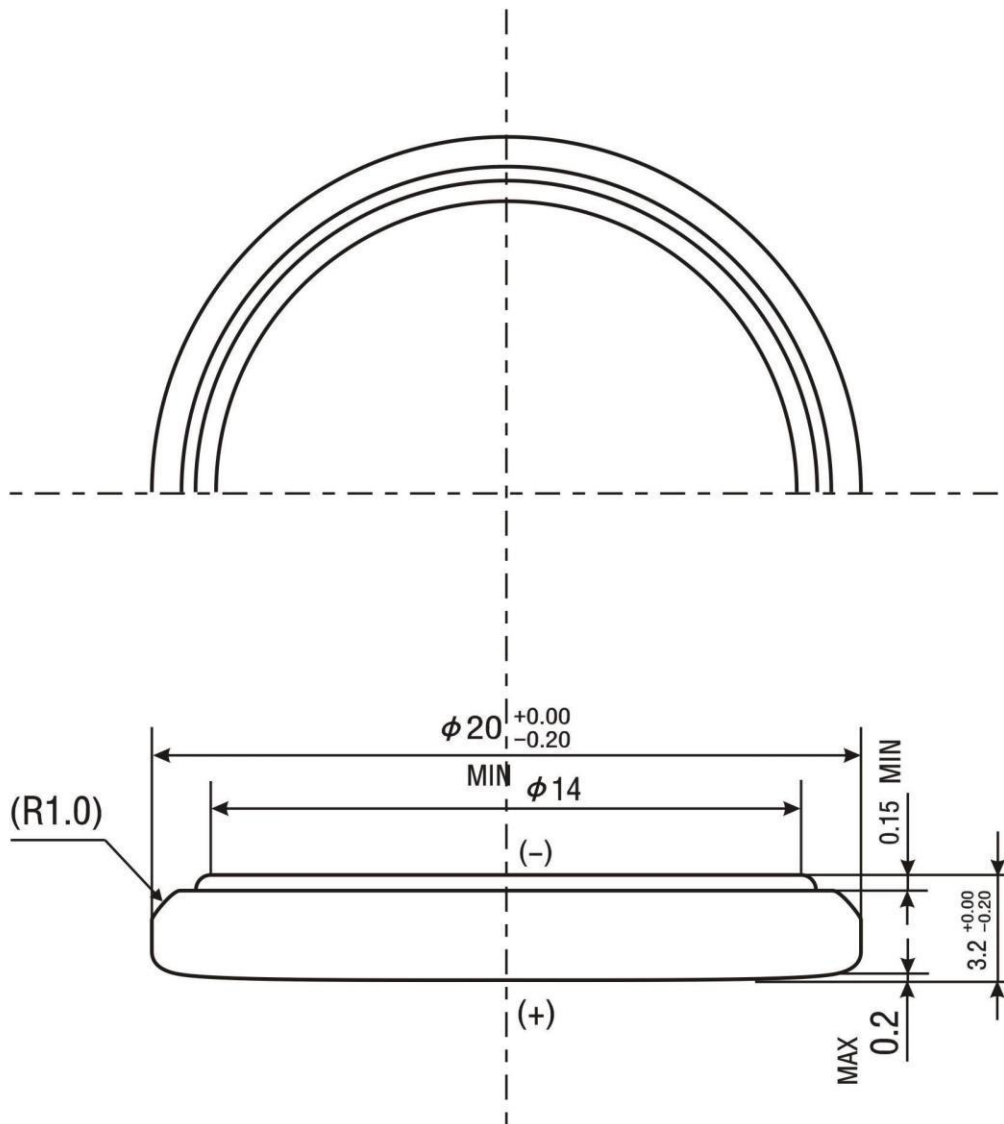

Unit:mm

			PROJECTION	SCALE	TITLE
				5/1	CR2032H
Dwn. BY	Shiyuanyuan	2017.01.08	EAST (SHENZHEN) TECHNOLOGY CO. , LTD		WORKS DWG. NO. 23.2032.06-A
CHK. BY	Zhuminfei	2017.01.08			
APP. BY	Wujunhao	2017.01.08			

Instructions for Usage and Safety

The battery consists of lithium, organic, solvent, and other combustible materials. Proper handling of the battery is of utmost importance; otherwise, the battery could lead to distortion, leakage (accidental seepage of liquid), overheating, explosion, or fire and cause bodily injury or damage to equipment. Please strictly comply with the following instructions to avoid the occurrence of accident.

WARNING for Handling

- **Do Not Ingest**
The battery should be properly stored and keep away from children in order to avoid them to put it into their mouths and ingest it. However, if it happens, you should immediately take them to the hospital.
- **Do Not Recharge**
The battery is not a rechargeable battery. You should never charge it as it could generate gas and internal short-circuiting, leading to distortion, leakage, overheating, explosion, or fire.
- **Do Not Make Hot**
If the battery is being heated to more than 100 degree centigrade, it would increase the internal pressure resulting distortion, leakage, overheating, explosion, or fire.
- **Do Not Burn**
If the battery is burnt or put to flame, the lithium metal will melt and cause explosion or fire.
- **Do Not Dismantle**
The battery should not be dismantled as it will cause damage to separator or gasket resulting distortion, leakage, overheating, explosion, or fire
- **Do Not Make Improper Setting**
The improper setting of the battery could lead to short-circuiting, charging or forced-discharging and distortion, leakage, overheating, explosion, or fire could be occasioned as a result. When setting, the positive and negative terminals should not be reversed.
- **Do Not Short-circuit The Battery**
The short-circuit should be avoided for positive and negative terminals. Do you carry or keep battery with metal goods; otherwise, battery could occasion distortion, leakage, overheating, explosion, or fire.
- **Do Not Directly Weld The Terminal or Wire to The Body of The Battery**
The welding will cause heat and occasion lithium melted or insulating material damaged in the battery. As a result, the distorting, leakage, overheating, explosion, or fire would be caused. The

battery should not be soldered directly to equipment which it must be done only on tabs or leads. The temperature of soldering iron must not be over 50 degree C and the soldering time must not be more than 5 seconds; it is important to keep the temperature low and the time short. The soldering bath should not be used as the board with battery could stop on the bath or the battery could drop into the bath. It should avoid taking excessive solder because it could go to unintended portion on the board resulting short or charge of the battery.

- Do Not Use Different Batteries Together

It must be avoided for using different batteries collectively because batteries of different types or used and new or different manufacturers could occasion distortion, leakage, overheating, explosion, or fire. Please obtain advice from HOLITH if it is necessary for using two or more batteries connected in series or in parallel.

- Do Not Touch The Liquid Leaked Out of Battery

In case the liquid leaked and get into the mouth, you should immediately rinse your mouth. In case the liquid gets into your eyes, you should immediately flush eyes with water. In any event, you should go to the hospital and have proper treatment from a medical practitioner.

- Do Not Bring Fire Close to Battery Liquid

If the leakage or strange smell is found, immediately put the battery away from fire as the leaked liquid is combustible.

- Do Not Keep in Touch with Battery

Try to avoid keeping the battery in touch with the skin as it will get hurt.

WARNING for Disposal

There are different regulations in different countries or regions and please comply with those regulations. In general, the insulating tape or friction tape should be used to cover the (+) and (-) terminals before disposal. It is because the discarded battery still has electric capacity and when it is in touch with other metals or materials, it could occasion distortion, leakage, overheating, or explosion.

WARNING for Circuit Design for Back-up Use

The battery is not rechargeable. It is important that the diodes are applied for prevention of charging from the main power or other batteries when the battery is used for the device having memory or RTC back-up applications. In addition, the application of protective resistance is necessary as it can regulate the current as shown in the figure below. The following points have to be paid attention when choosing diodes and protective resistance.

- Supplied voltage to load

Due to the application of a diode and a resistance, the voltage generated will drop during operation, you are reminded to pay attention to these drops of voltage for supplied voltage to load.

- Prevent charging by applying diodes

It is recommended to use the least leak current diodes. The charged capacity owing to leak current should be maintained within 1% of nominal capacity.

- Using and setting protective resistance

In order to refrain from changing the battery by large surges of current when the diode is failed, the protective resistance should be applied. It is recommended to adjust the protective resistance to make the maximum current not over the figures as stated in the table.

CAUTION (Handling / Storage)

- Do Not place the battery in ultrasonic

The short-circuit may be caused if the battery is placed in ultrasonic as the materials inside may be powdered occasioning distortion, leakage, overheating, explosion, or fire.

- Do Not roughly handle the battery

Distortion, leakage, overheating, explosion, or fire might be caused if the battery is received heavy impact or strong shock.

- Do Not short-circuit the battery while putting into equipment

It is advised to put the battery to the equipment in a prudent way. It is because the short-circuit may occurs to the battery through metal parts of the equipment.

- Do Not maintain contact pressure less than 2N

Due to the poor contact condition, the intended value may be higher than the battery voltage. For appropriate contact resistance, the contact pressure must be maintained not less than 2N.

- Do Not wrongly match the battery and equipment

Please use the proper battery conforming to the handling manual of the equipment. It is because the specifications or types of equipments are different and the battery may not fit all kinds of equipments.

- Do Not put the battery in hot place such as under the sun or in the car in the daytime

If the battery is put in hot place, it may cause distortion, leakage, overheating, explosion, or fire of the battery.

- Do Not allow the battery touch water

If the battery touches water may occasion distortion, leakage, overheating, explosion, or fire. It may also generate rust.

- Do Not stock the battery in the condition of high humidity and heat

In the high humid and hot condition, the battery may deteriorate. It may cause the battery distorted, leaked, overheated, or exploded.

SPECIFICATION FOR INSPECTIONS

It is guaranteed that this specification of the inspections will be fulfilled by our products. HOLITH shall identify the cause of the problem and proceed to take remedial actions if the products do not fulfill this specification of inspections.

1. Quality Standard

The product specification will be conformed.

2. Unit of Inspections

One battery will be taken as one unit of inspection.

3. Definition of Lot

A batch of products that are manufactured by the same production lines with the same lot code mark.

4. Test Method

The product specification will be confirmed.

5. Sampling Plan

The following table is referred and is only used for the initial test.

	Inspection Item	Inspection Plan	Sampling Level	A.Q.L
1	Dimensions	GB/T8897.2-2008	China National Standard	1.0
2	Open Circuit Voltage	GB/T8897.2-2008	China National Standard	1.0
3	Appearances	GB/T8897.2-2008	China National Standard	1.5

Major Defect: If there is failure on the functions of the products, it will be construed as major defect.

Others: Defect that is distinguished from Major Defect.

The operating features by attributes are used as a base for sampling inspections.