

局部视图P Local view P

料号P/N	颜色colour
XT08X-P32	壳体颜色: 灰色Shell color: gray
XT08X-P32-BK	壳体颜色: 黑色Shell color: black

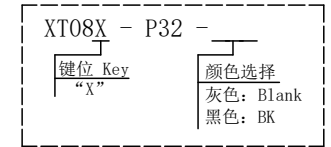

规格参数:

- 1、工作温度Operating temperature: -40℃~125° ℃。
- 2、额定电流Current rating:  
Power: 13A MAX; Signal: 5A MAX。
- 3、配对线径Cable Size:  
Power: 16-18 AWG; Signal: 20-22 AWG。
- 4、耐电压Dielectric withstanding voltage: 3000 VDC。
- 5、防护等级Protection class: IP67。
- 6、机械寿命Mating cycle: 100 Min。
- 7、法兰盘螺丝安装扭矩Screw Assembly Torque on Flange: 1.6-2.4 Nm。
- 8、对配插头见图纸Mating plug see drawing: "XT18X-S32"。
- 9、端子电镀信息。  
Terminal plating specification: See below。  
镍底, 整个端子镀金。  
Gold flash plating overall。

注:

- 1、安装面板厚度"A"选用3.5mm,  
the thickness of the installation panel "A" is 3.5mm,  
根据GB/T70.1-2000, 内六角圆柱头螺钉的杯头厚度为4.0mm(Max),  
According to GB/T70.1-2000, the cup head thickness of the  
hexagonal cylindrical head screw is 4.0mm(Max),  
根据GB 97.1-85平垫圈的度为0.8mm ;  
The degree of the flat washer according to GB 97.1-85 is 0.8mm;
- 2、安装面板厚度"A"选用5mm,  
the thickness of the installation panel "A" is 5mm,  
根据DIN7984-2009, 六角圆柱头螺钉的杯头厚度为2.8mm(Max),  
According to DIN 7984-2009, the cup head thickness of hexagonal  
cylindrical head screws is 2.8mm(Max),  
根据GB 97.1-85平垫圈的度为0.8mm ;  
The degree of the flat washer according to GB 97.1-85 is 0.8mm;

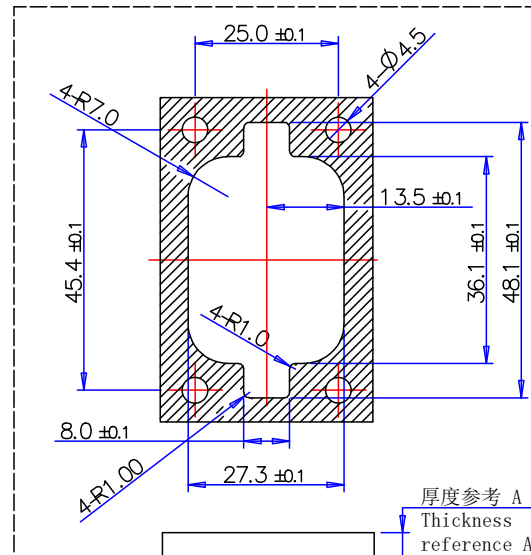

安装板开孔尺寸 Panel Size

发行版本 Revision	A / 0
------------------	-------

修改内容 Description	First release
---------------------	---------------

制图 Drawing	Xiong
日期 Date	2023. 11. 21

适用端子型号Applicable terminal type					
端子种类 Terminal type	端子料号 Terminal P/N	适合电线 Wire range	电线外径范围 Wire OD range	盲堵种类 Seal type	盲堵料号 Seal P/N
16# (Power)	XTM1611	16~18AWG	1.70~2.40 mm	16# (Power)	XT-SP-16
20# (Signal)	XTM2011	20~22 AWG	1.35~1.90 mm	20# (Signal)	XT-SP-20

客户料号 Cus' P/N	图号 File No.	RHT-710-0002	品名 Name	XT 32CKT 插座直式 XT 32CKT Rcpt Rear Code
未注公差 Unless Otherwise Specified	单位 Unit	mm	版本 Revision	A/0
线性 Linear	0.5~6 ±0.2 >6~30 ±0.3 >30 ±2%	比例 Scale	—	—
角度Angles	±3°	页码 Page	1 / 1	—
Third Angle Projection		图纸确认 APPROVAL		
—		绘图 Drawing	Xiong	日期 Date 2023. 11. 21
—		审核 Checked	Jim	2023. 11. 21
—		客户确认 Customer Approved	—	