



Jiangmen Hongli Energy Co., Ltd.

PRODUCT SPECIFICATION

Product	Lithium manganese dioxide battery				
Model Number	CR14250				
Outer Dimension	(H*Φ) 14.5*25mm				
Drafted	Xueying Li	Checked	Huier Chen	Approved	Jingxian Chen
2021- 7 - 22	2021- 7 - 22		2021- 7 - 22		

CR14250 Specification	
File No: HL-SM-CR14250-001	Effective Date: 2021-7-22
Version: A/1	Page: 2 / 11

Catalogue

- 1. Application Scope 3
- 2. Standard Parameters..... 3
- 3. Performance Standard..... 4
 - 3.1 Appearance..... 4
 - 3.2 Standard testing conditions 4
 - 3.3 Leakage Resistance..... 4
 - 3.4 Discharge Curve..... 4
 - 3.5 Safety Performance 5
 - 3.6 Mechanical Safety Performance..... 5
- 4. Precautions for used 6
- 5. Important Notes..... 6
- 6. Battery Dimension..... 7
- 7. Battery Packing 8
- 8. History of Revision..... 9

1 Application Scope

The specification describes standard parameters, electrical characteristics, safety performance, environmental adaptability, test and judgment, operation instructions and safety regulations of the battery.

2 Standard Parameters

No.	Item	Parameter	Notes
1	Capacity	800mAh	
2	Discharge current	5mA	
3	Cut-off voltage	1.5V	
4	Open-circuit voltage	3.00~3.40	
5	Max. continuous discharge current	800mA	
6	Max. pulse current	1500mA	
7	-20°C discharge (20mA/1.5V)	>400mAh	
8	Operating Temperature	-40°C ~ 70°C	
9	Storage Temperature	-0°C ~ 40°C	
10	Weight	9g	
11	Dimension (H*Φ)	(14.0±0.5) * (24.0±1) mm	
12	self-discharge (per year)	< 1%	

3 Performance Standards

3.1 Appearance

The surfaces of the batteries are clean. There should not be deformation, rust, stain or leakage.

3.2 Standard testing conditions

Unless otherwise specified elsewhere, tests should be conducted at

Temperature: $25 \pm 5^\circ\text{C}$ Humidity: 45 ~ 75% barometric pressure: 86 ~ 106kpa

3.3 Leakage Resistance

After 24 hours at 70°C , the battery was placed at room temperature for 8 hours for visual inspection. There was no leakage, explosion and fire.

3.4 Discharge Curve

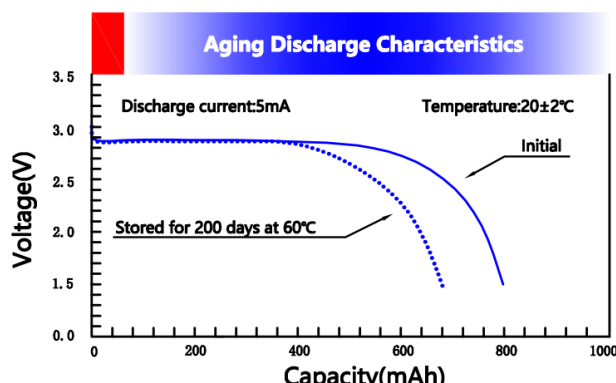
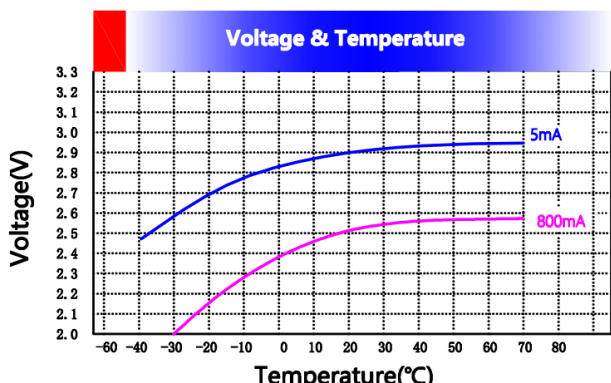
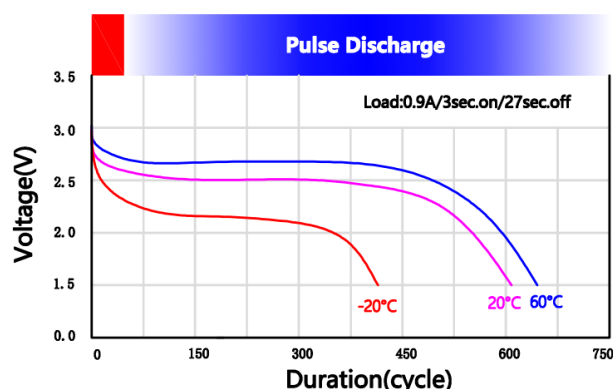
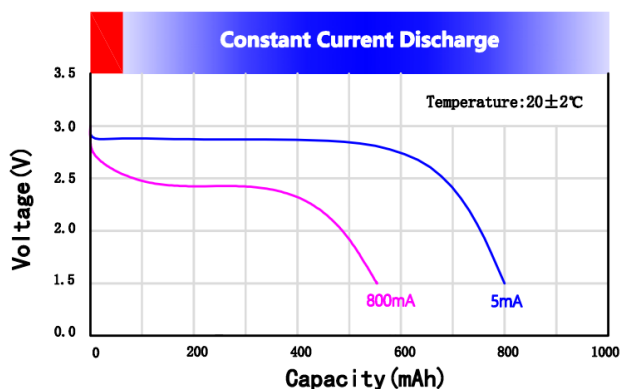

3.5 Safety Performance

Item	Test method	Standard
External short-circuit (55°C)	After the shell temperature of the tested battery is stable at 55°C, conduct external short circuit to the battery at this temperature, and the total resistance of the external circuit shall be less than 0.1 Ω. The short circuit shall be continued for at least 1 h after the temperature of the battery shell falls back to 55 °C. Continue to observe the samples for 6 hours.	No explosion No fire
Free Fall	The battery without being discharged falls on the concrete surface from a height of 1 m, each battery shall be dropped 6 times, twice in X, y and Z axes, and then the tested battery shall be placed for 1 h.	No leakage, No explosion No fire
"3 + 1" reverse charge (single battery)	The tested battery is connected in series with three non-discharged batteries of the same model containing a single battery, and the tested battery is connected in reverse with other batteries. The resistance of the circuit shall not be more than 0.1 Ω. Turn on the circuit for 24 hours, or until the temperature of the battery shell returns to the ambient temperature.	No explosion No fire
Heat shock	The tested battery was placed at 75°C for at least 6 hours, and then at - 40°C for at least 6 hours. The conversion time of different temperatures should not exceed 30 min. After 10 cycles, each battery was placed at ambient temperature for at least 24 h.	No leakage, No explosion No fire

3.6 Mechanical safety performance

Item	Test method	Standard
Vibration test	The tested battery shall be firmly fixed on the vibration platform of the vibration equipment in such a way that the vibration can be truly transmitted without deformation of the battery. The vibration amplitude of sine wave was 0.8mm. In three mutually perpendicular fixed directions, 12 cycles were carried out in each direction, and the cycle time of each azimuth was 3 h. One of the orientations should be perpendicular to the end face of the battery.	No leakage, No explosion No fire
Crush Test	The long axis of the tested battery is squeezed between the two planes by applying pressure through a vise or a hydraulic cylinder with a cylindrical piston. From the initial contact point, the extrusion is carried out continuously at a speed of about 1.5 cm / s until the extrusion force reaches about 13 kn and the pressure is released immediately. The pressure can be applied through a hydraulic cylinder with a piston diameter of 32 mm until the pressure reaches 17 MPa (13 KN). Each single cell or cell battery is extruded only once. Observe the battery for at least 6 h.	No leakage, No explosion No fire
Shock test	The tested battery is fixed on the testing equipment with a rigid support which can support all fixed surfaces of the tested battery. Each battery is subjected to three times of impact in three mutually	No explosion No fire

perpendicular fixed directions, a total of 18 times.				
Impact parameters				
Battery type	waveform	peak acceleration	pulse duration	Number of impacts per axle shaft
Small	half-sine wave	150g	6ms	3

4. Precautions for Used

The battery has an explosion resistant construction. But the following cautions should be taken, because combustible materials such as lithium metal and organic electrolyte are contained in the battery.

- * Do not use except inapplicable model or equipment
- * Do not connect more than three cells in series
- * Do not mix different types (chemistries) of batteries
- * Do not short circuit.
- * Do not dispose in fire
- * Do not charge.
- * Do not disassemble
- * Do not connect the wrong polarity (+,-)

5. Important Notes (Warranty)

5.1 **Warning** Fire and burn hazard. Do not recharge, short circuit, over discharge, crush, disassemble, heat above 100°C(212°F) or incinerate. Keep battery far away from children put them in original package until ready to use. Dispose of used batteries promptly.

5.2 When customer does any work on the battery ignoring instructions in this specification, for example wire is soldered to the tab or battery surface directly; Jiangmen Hongli Energy, Co Ltd. cannot warrant any battery performance

including safety and the customer should undertake the responsibility of all damage caused by this battery.

- 5.3 Do not solder the battery directly. Excessive heating may cause deformation of the battery components such as the gasket, which may lead to the battery swelling, leakage, explosion or ignition. High temperature and long time may cause heat gathered.
 - 5.4 Observe the soldering condition for the tabbed battery to be specified by the manufacturer. Choose the tabbed battery if soldering is required.
Excessive heating may cause deformation of the gasket, leakage or performance deterioration of the battery.
 - 5.5 Tabs can be soldered on the battery terminals directly by spot-welding. The parameters of the spot-welder must be adjusted carefully to avoid the battery being perforated, changing voltage and temperature rising above 65°C. Assure not to exceed the battery temperature higher than 60°C at soldering.
 - 5.6 Battery characteristics vary with type and grade, even when batteries are the same size and shape. When replacing batteries with new ones, be sure to carefully check the symbols and numbers on each battery.
 - 5.7 Please design equipment so that infants cannot easily remove batteries and swallow them.
-

CR14250 Specification	
File No: HL-SM-CR14250-001	Effective Date: 2021-7-22
Version: A/1	Page: 9 / 11

6. The Battery Dimensions

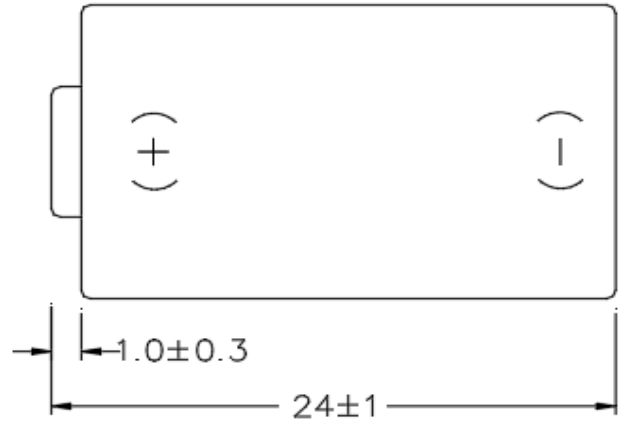
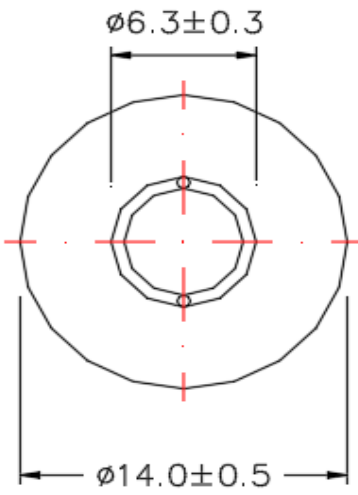

Unit: mm

7. Battery Packing Specification

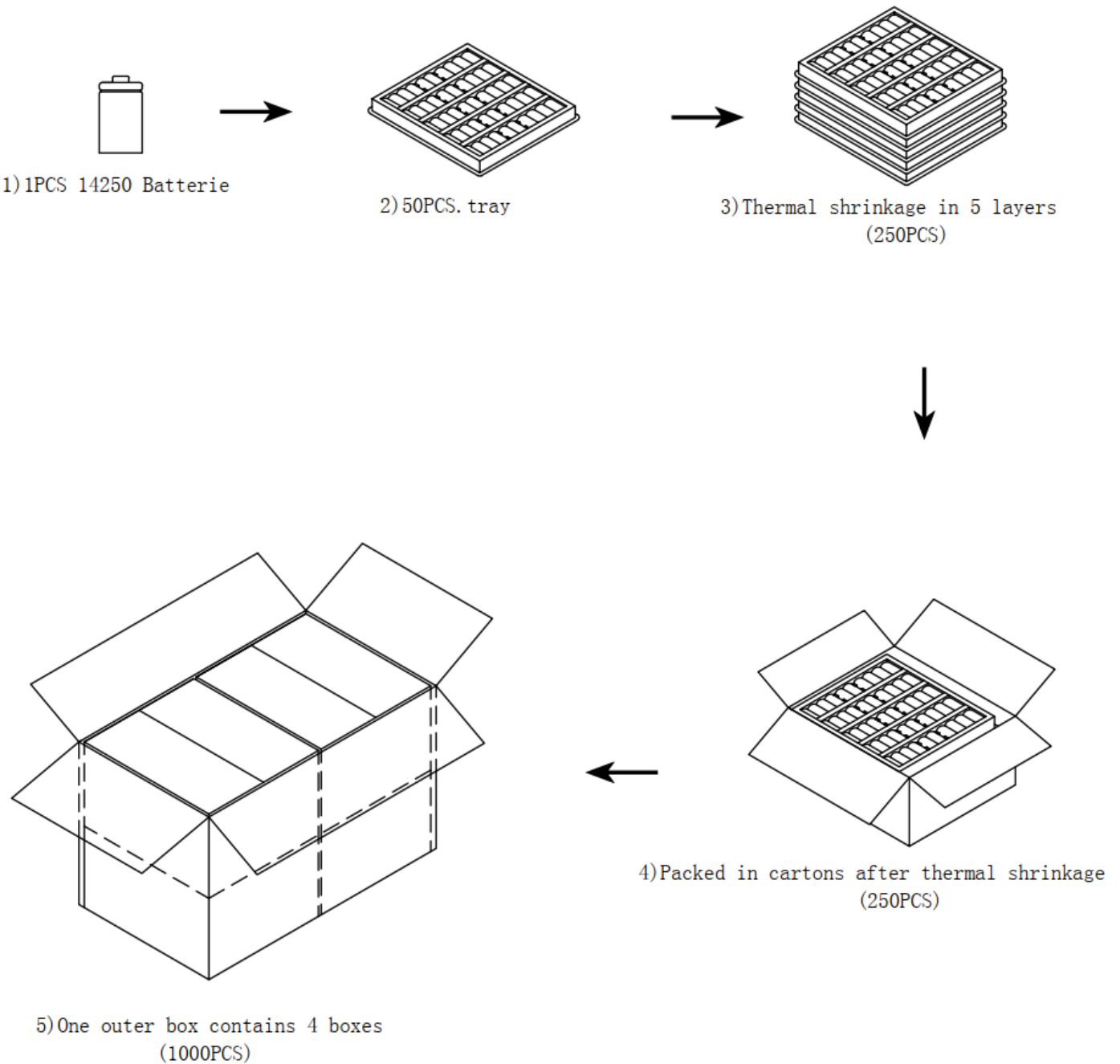

Packing list

QTY: 1000PCS

G. W: 10KGS

N. W: 9KGS

MEAS: 42X24X24.5CM



CR14250 Specification	
File No: HL-SM-CR14250-001	Effective Date: 2021-7-22
Version: A/1	Page: 11 / 11

8. History of Revision

Change Description

Number	Date	Version	Detail	Revised	Approved
1	2019-2-16	A/0	Issue		
2	2021-7-22	A/1	New Version		

