



1. Scope

This specification applies to the HPSM series of SMD power inductor.

2. Product Identification

HPSM 201610 BE 1R0 M 26 - LF
 ① ② ③ ④ ⑤ ⑥ ⑦

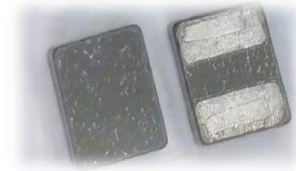

- ① Product Symbol
- ② Product dimensions
- ③ Special process code
- ④ Inductance Value (R47:0.47 uH; 1R0: 1.0uH; 100:10uH)
- ⑤ Inductance Tolerance (M: ±20%)
- ⑥ Process code
- ⑦ Lead free product.

3. Appearance and Dimensions

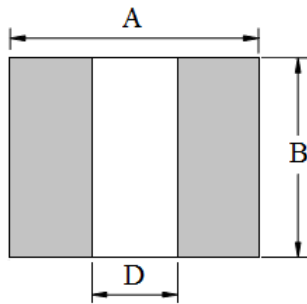

Note: Gray area is electrode

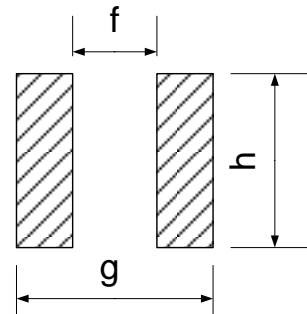

Recommended Land Pattern

Series	Dimensions (mm)						
	A	B	C (Max.)	D (Typ.)	f (Typ.)	g (Typ.)	h (Typ.)
HPSM141206	1.4±0.2	1.2±0.2	0.65	0.60	0.50	1.60	1.40
HPSM141208	1.4±0.2	1.2±0.2	0.80	0.60	0.50	1.60	1.40
HPSM160808	1.6±0.2	0.8±0.2	0.80	0.50	0.40	1.70	0.90
HPSM201208	2.0±0.2	1.2±0.2	0.80	0.60	0.50	2.20	1.40
HPSM201608	2.0±0.2	1.6±0.2	0.80	0.60	0.50	2.20	1.80
HPSM201610	2.0±0.2	1.6±0.2	1.00	0.60	0.50	2.20	1.80
HPSM252010	2.5±0.2	2.0±0.2	1.00	0.70	0.60	2.70	2.20
HPSM322512	3.2±0.2	2.5±0.2	1.20	0.90	0.80	3.50	2.90



4. Testing Conditions

Unless otherwise specified, the standard conditions for measurement/test as:

Ambient Temperature : 5 to 35°C

Relative Humidity: 25 to 85% RH

Atmospheric Pressure: 86 to 106 kPa

If any doubt on the results, measurements/tests should be made within the following limits:

Ambient Temperature : 25 ±1 °C

Relative Humidity: 60 to 70% RH

Atmospheric Pressure: 86 to 106 kPa

5. Electrical Characteristics And Test Instruments

HPSM141206 Series

HONGDA Part No.	Inductance (uH)	DCR (mΩ)		Isat (A)		Irms (A)	
		Max.	Typ.	Max.	Typ.	Max.	Typ.
HPSM141206BER33M20-LF	0.33±20%	40	35	5.0	5.5	2.8	3.0
HPSM141206BER47M20-LF	0.47±20%	50	42	3.0	3.3	2.4	2.6

HPSM141208 Series

HONGDA Part No.	Inductance (uH)	DCR (mΩ)		Isat (A)		Irms (A)	
		Max.	Typ.	Max.	Typ.	Max.	Typ.
HPSM141208BER33M20-LF	0.33±20%	27	22	4.4	4.8	3.4	3.7
HPSM141208BER47M20-LF	0.47±20%	38	33	3.7	4.2	2.8	3.0

HPSM160808 Series

HONGDA Part No.	Inductance (uH)	DCR (mΩ)		Isat (A)		Irms (A)	
		Max.	Typ.	Max.	Typ.	Max.	Typ.
HPSM160808BER56M20-LF	0.56±20%	60	52	2.7	3.1	2.2	2.5
HPSM160808BE1R0M20-LF	1.0±20%	144	120	2.0	2.2	1.6	1.8
HPSM160808BE2R2M20-LF	2.2±20%	290	241	1.2	1.3	1.0	1.1

HPSM201208 Series

HONGDA Part No.	Inductance (uH)	DCR (mΩ)		Isat (A)		Irms (A)	
		Max.	Typ.	Max.	Typ.	Max.	Typ.
HPSM201208BER24M21-LF	0.24±20%	20	16	5.6	6.1	5.1	5.4
HPSM201208BER33M20-LF	0.33±20%	27	23	5.0	5.6	4.2	4.5
HPSM201208BER47M21-LF	0.47±20%	27	24	4.8	5.2	4.0	4.2
HPSM201208BER56M22-LF	0.56±20%	47	40	3.3	3.7	3.2	3.5
HPSM201208BE1R0M20-LF	1.0±20%	60	50	3.2	3.4	2.8	3.1
HPSM201208BE2R2M-LF	2.2±20%	161	148	1.8	2.2	1.6	1.8



HPSM201608 Series

HONGDA Part No.	Inductance (uH)	DCR (mΩ)		Isat (A)		Irms (A)	
		Max.	Typ.	Max.	Typ.	Max.	Typ.
HPSM201608BER47M20-LF	0.47±20%	26	22	4.8	5.2	4.5	4.9
HPSM201608BE1R0M20-LF	1.0±20%	52	38	4.1	4.5	3.6	3.8
HPSM201608BE2R2M20-LF	2.2±20%	90	83	2.7	2.9	2.3	2.5

HPSM201610 Series

HONGDA Part No.	Inductance (uH)	DCR (mΩ)		Isat (A)		Irms (A)	
		Max.	Typ.	Max.	Typ.	Max.	Typ.
HPSM201610BER24M20-LF	0.24±20%	19	155	7.2	7.9	5.4	5.8
HPSM201610BER47M20-LF	0.47±20%	26	20	5.5	6.0	4.5	5.0
HPSM201610BE1R0M26-LF	1.0±20%	45	40	4.2	4.5	4.1	4.3
HPSM201610BE2R2M20-LF	2.2±20%	102	84	2.4	2.7	2.1	2.3

HPSM252010 Series

HONGDA Part No.	Inductance (uH)	DCR (mΩ)		Isat (A)		Irms (A)	
		Max.	Typ.	Max.	Typ.	Max.	Typ.
HPSM252010BER47M-LF	0.47±20%	22	18	6.5	7.2	5.7	6.0
HPSM252010BE1R0M25-LF	1.0±20%	30	25	5.0	5.5	4.5	4.8
HPSM252010BE2R2M-LF	2.2±20%	85	78	3.6	4.1	2.7	2.9
HPSM252010BE4R7M-LF	4.7±20%	180	150	2.0	2.4	1.8	2.0

HPSM322512 Series

HONGDA Part No.	Inductance (uH)	DCR (mΩ)		Isat (A)		Irms (A)	
		Max.	Typ.	Max.	Typ.	Max.	Typ.
HPSM322512BE0-LF	0.47±20%	18	14.5	8.0	9.0	6.0	6.6
HPSM322512BER68M20-LF	0.68±20%	22	18	5.0	5.5	4.8	5.3
HPSM322512BE1R0M-LF	1.0±20%	36	31	7.0	8.0	4.0	4.4

Test instruments and remarks

- * L test by CHROMA 3302 meter or equivalent
- * DCR test by Tonghui TH2516B meter or equivalent
- * CHROMA 3302 and 1320 meter for IDC;
- * Isat: DC current (A) that will cause L0 to drop approximately 30%.
- * Irms: DC current (A) that will cause an approximate ΔT of 40°C.
- * All test data is referenced to
- * Operating temperature: -55°C to +125°C. (Including self_heating).
- * The part temperature (ambient + temp rise) should not exceed 125 under worst case operating conditions. Circuit design, component placement, PCB trace size and thickness, airflow and other cooling provision all affect the part temperature. Part temperature should be verified in the end application.

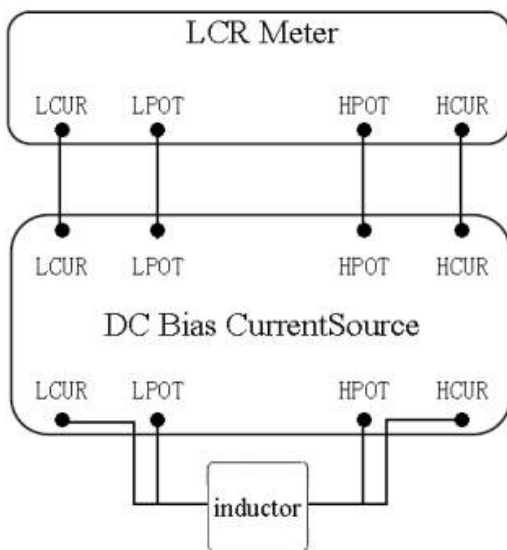

Isat test schematic diagram

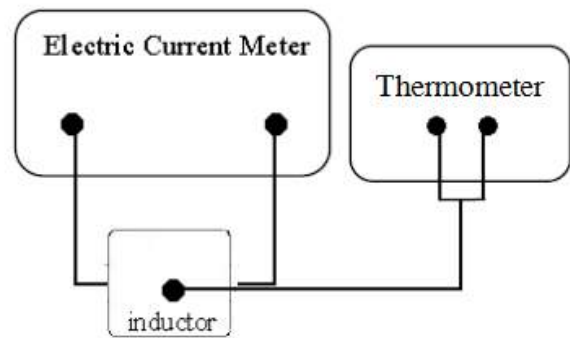

Irms test schematic diagram

6. Condition of work

Operating temperature range: -55°C ~ +125°C (Including self-heating).

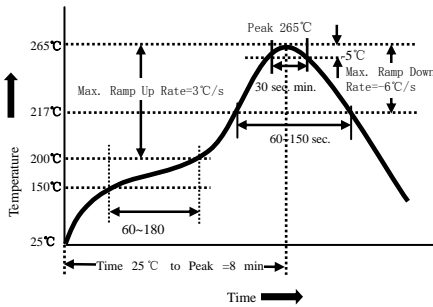
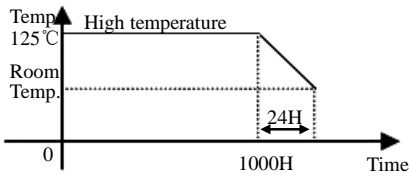
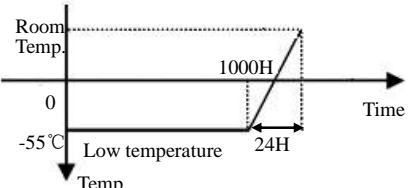
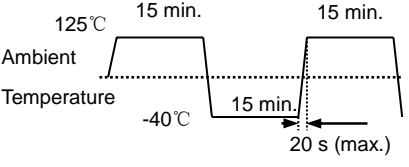

7. Reliability

No.	Item	Requirements	Test Methods and Remarks	Reference	Sample Size
1	Solderability	(1) No physical damage. (2) Terminal area must have 95% min. solder coverage.	①Temperature: 245 ± 5 °C, flux 5-10 s. ②Sample immersion tin furnace 5 ± 0.5s. ③Immersed and in and out of speed: 25 ± 6mm/s.	AEC-Q200 (J-STD-002)	15
2	Resistance to Soldering Heat		①The peak temperature: 260+5/-0°C. ②Reflow: 3times. ③Temperature curve is as below: 	AEC-Q200 (MIL-STD-202 Method 210)	30
3	High Temperature Storage	(1) No physical damage.	①Temperature: 125 ± 2 °C. ②Time : 1000 hours. ③Measurement at 24 ± 4 hours after test conclusion. 	AEC-Q200 (MIL-STD-202 Method 108)	77
4	Low Temperature Storage	(2) ΔL0/L0 ≤ 10%	①Temperature: -55 ± 2 °C. ②Time : 1000 hours. ③Measurement at 24 ± 4 hours after test conclusion. 	JESD22-A119	77
5	Thermal shock		①First -40°C for 15 minutes, last 125°C 15minutes as 1 cycle. Go through 300 cycles. ②Max transfer time is 20 second. ③Measurement at 24 ± 4 hours after test conclusion. 	MIL-STD-202 Method 107	30

No.	Item	Requirements	Test Methods and Remarks	Reference	Sample Size
6	Humidity Resistance	(1) No physical damage. (2) $ \Delta L_0/L_0 \leq 10\%$	①1000 hours, 85 °C/85%RH. ②Unpowered. ③Measurement at 24±4 hours after test conclusion. 	AEC-Q200 (MIL-STD-202 Method 103)	77
7	Terminal Strength	No physical damage.	①The test samples shall be soldered to the board. ②17.64N, 60s. 	AEC-Q200 (AEC-Q200-006)	30
8	Board Flex	(1) No physical damage. (2) $ \Delta L_0/L_0 \leq 10\%$	①Part mounted on a 100mm*40mm FR4 PCB board, which is 1.6±0.2 mm thick and as a Layer-thickness 35 μm ± 10 μm. ②Bending speed is 1mm/s. ③Keeping the P.C Board 2 mm minimum for 60 seconds. 	AEC-Q200 (AEC-Q200-005)	30
9	Drop		①Height: 1 m, Free fall, 10times. ②Direction: 1 Angle, 1side, 2surface.	JESD22-B111	30
10	Vibration		①Frequency range : 10~2000Hz. ②Amplitude: 1.5mm, 5g. ③Sweep time and duration: 10~2000~10Hz for 20 minutes. ④Each four hours in X,Y,Z direction, 12 hours in total.	AEC-Q200 (MIL-STD-202 Method 204)	30



No.	Item	Requirements	Test Methods and Remarks	Reference	Sample Size
11	Loading at High Temperature	(1) No physical damage. (2) $ \Delta L0/L0 \leq 10\%$	①Temperature: $85 \pm 2^\circ\text{C}$. ②Time : 1000 hours. ③Applied Current : Rated current. ④Measurement at 24 ± 4 hours after test conclusion.	AEC-Q200 (MIL-PRF-27)	77

*All above experiments items need 3 Lot., sample size is as specified in the table above.

*Sample size standard is from AEC-Q200 : qualification sample size requirements.

8. Recommended Soldering Conditions

(1) Reflow soldering conditions

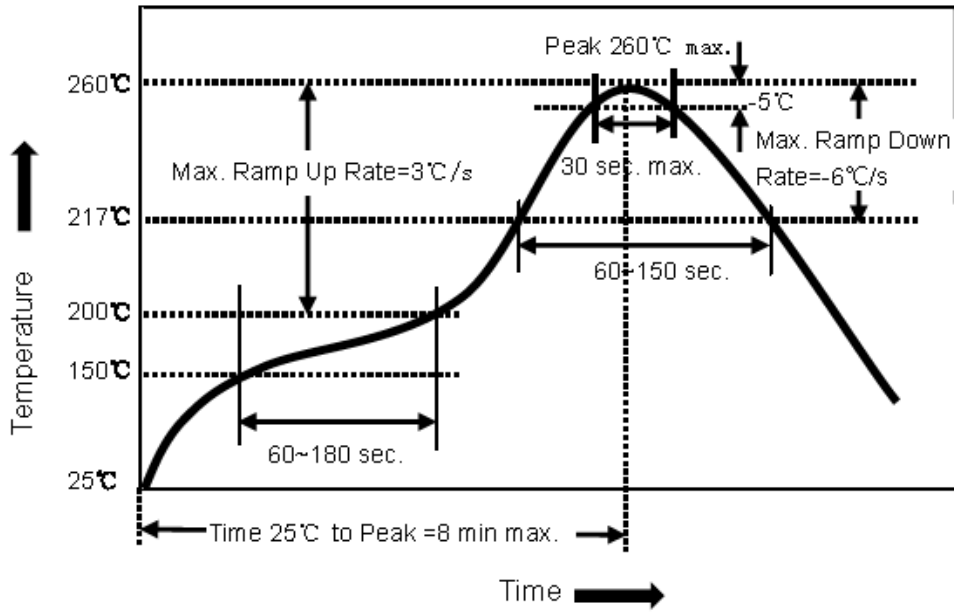

*Above reflow soldering curve is from J-STD-020D.

(2) Iron soldering

The following conditions must be strictly followed when using a soldering iron.

Pre-heating	150°C 1 minute
Tip temperature	350°C max
Soldering iron output	30w max
End of soldering iron	φ 1mm max
Soldering time	3 seconds max



9. Package Information

(1) Dimension of tape (Unit: mm)

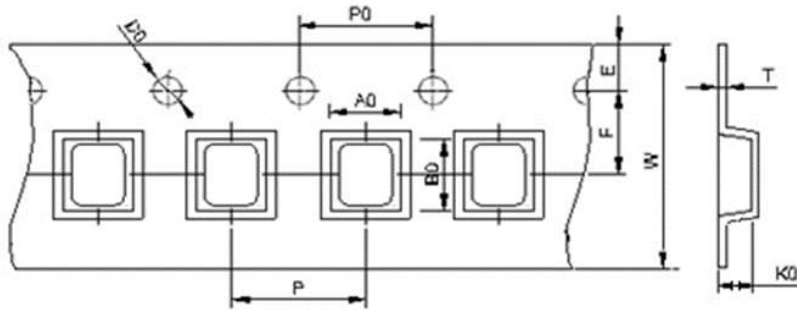

W	A0	B0	K0	E	F	P	P0	D0	T
8.0±0.1	2.00±0.10	2.35±0.10	1.10±0.1	1.75±0.1	3.5±0.1	4.0±0.1	4.0±0.1	1.5+0.1/-0.0	0.18±0.02

(2) Dimension of reel (Unit: mm)

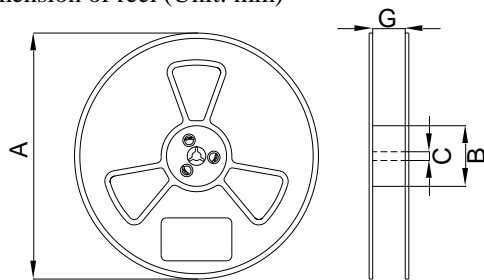

Symbol	Dimension
A	178±2
B	58±2
C	13.5±0.2
G	9.0±1.5

(3) Taping figure and drawing direction

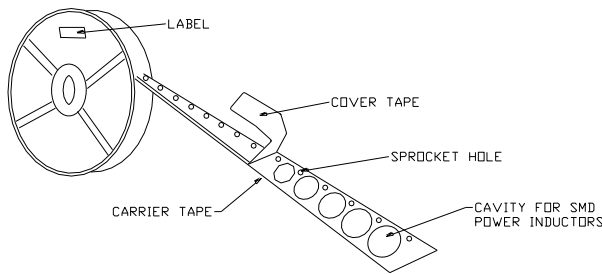

(4) Packaging quantities: 2000PCS/Reel.

(5) Peeling strength of cover tape:

The peel force of top cover tape shall be between 0.10N to 1.0N

*the peel force standard is from EIA-481-D

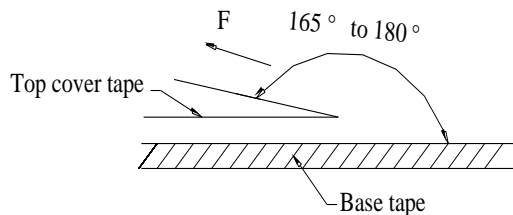

Room Temp. (°C)	Room Humidity (%)	Room aim (hpa)	Peel Speed mm/min
5-35	45-85	860-1060	300



10. Products Storage

(1) Storage period

Products which inspected in HONGDA over 12 months ago should be examined and used, which can be confirmed with inspection No. marked on the container. Solderability should be checked if this period is exceeded.

(2) Storage conditions

Products should be storage in the warehouse on the following conditions:

Temperature: -10 ~+ 35°C

Humidity: Less than 70% relative and humidity

No rapid change on temperature and humidity.

(3) Don't keep products in corrosive gases such as sulfur, chlorine gas or acid, or it may cause oxidization of electrode, resulting in poor solderability.

(4) Products should be storage on the palette for the prevention of the influence from humidity, dust and so on.

(5) Products should be storage in the warehouse without heat shock, vibration, direct sunlight and so on.

(6) Products should be storage under the airtight packaged condition.