

REV.	DESCRIPTION	DESIGN	APPROVAL	DATE
X2	RELEASED	W.C	D.H	15NOV2019
X3	ADD P/N	Daniel Lin	Hongji Cjen	2023.05.26

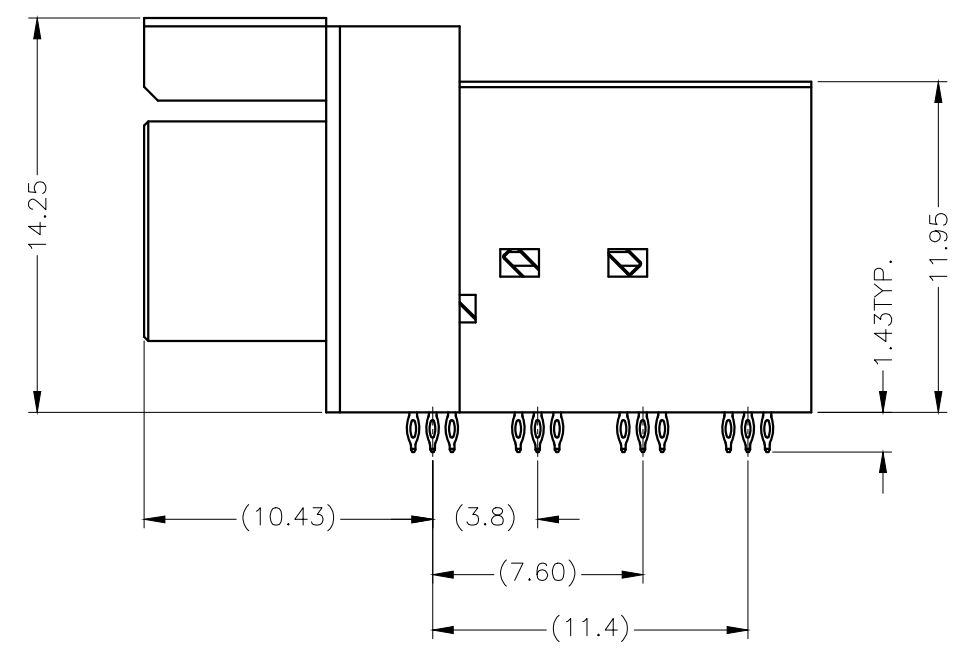
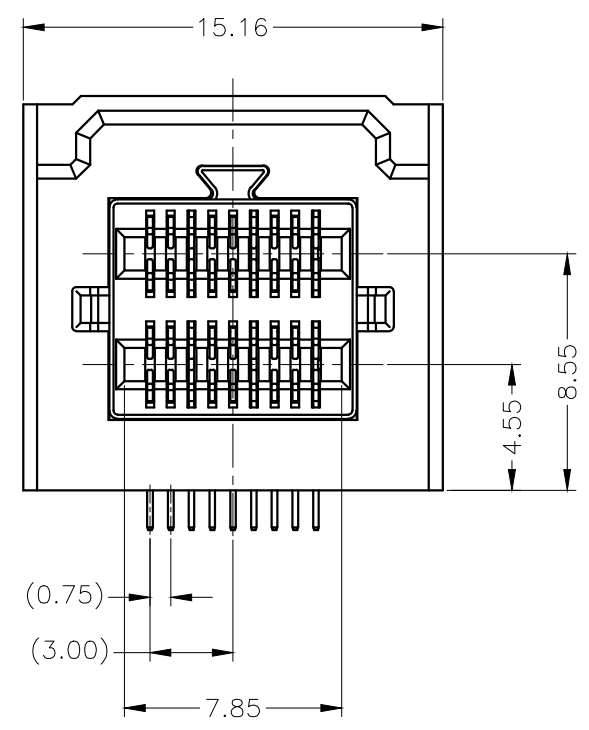

NOTES

- MATERIAL:
 HOUSING: HIGH TEMPERATURE THERMALPLASTIC, BLACK.
 BRACKET: HIGH TEMPERATURE THERMALPLASTIC, BLACK.
 INSERT MOLD HOUSING: HIGH TEMPERATURE THERMALPLASTIC, BLACK.
 CONTACTS: COPPER ALLOY.
- FINISH:
 CONTACT: GOLD PLATING ON CONTACT AREA
 MATTE TIN PLATING ON PRESS-FIT AREA
 NICKEL UNDER PLATING ALL OVER.
- APPLICABLE MOUNTING SCREW:
 M2X0.635 SELF-THREADING SCREW.
 LENGTH: PCB THICKNESS+ 3.0mm MAX.

⚠️ COMPONENT KEEP ZONE OUT AREA.

5. P/N : PMSB36-1300-X00-0H

0 : NO SCREW
 1 : WITH SCREW

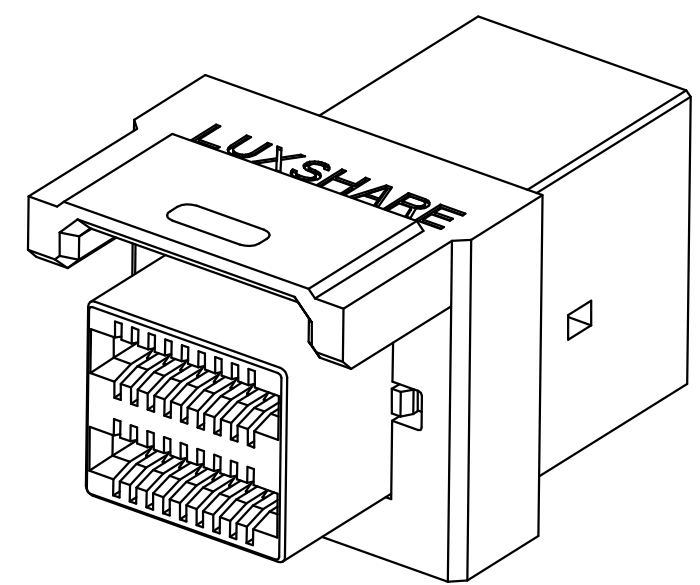
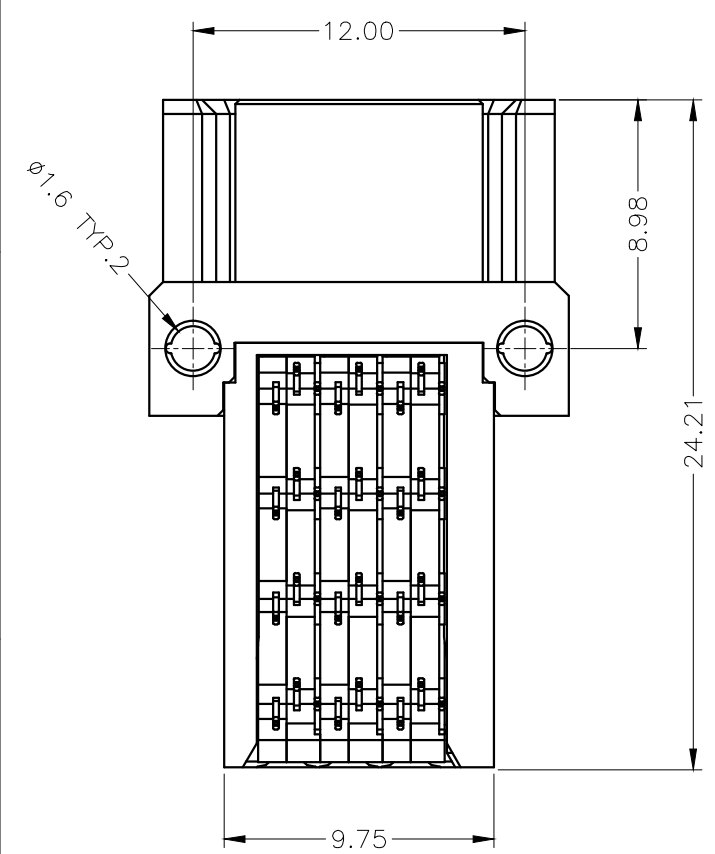

X.±0.25	X.°±5 °	PART NO.: PMSB36-130X-000-0H	LUXSHARE-ICT			
.X±0.25	.X°±5 °					
.XX±0.25	.XX°±5 °	TITLE: MINI-SAS HD CONNECTIR 1X1(12G)	CUSTOMER P/N: -			
.XXX±	.XXX°± °					
UNITS:	mm	APPD: Hongji Chen	DWG NO: PMSB36-1300-000-0H-00			
THESE DRAWINGS AND SPECIFICATIONS ARE THE PROPERTY OF LUXSHARE-ICT AND SHALL NOT BE REPRODUCED, COPIED OR CUED IN ANY MANNER WITHOUT THE PRIOR WRITTEN CONSENT OF LUXSHARE-ICT		CHKD: Hongji Chen		SCALE	SHEET	REV.
		DRAW: Daniel Lin		4:1	1 OF 2	X3

REV.	DESCRIPTION	DESIGN	APPROVAL	DATE
-	-	-	-	-

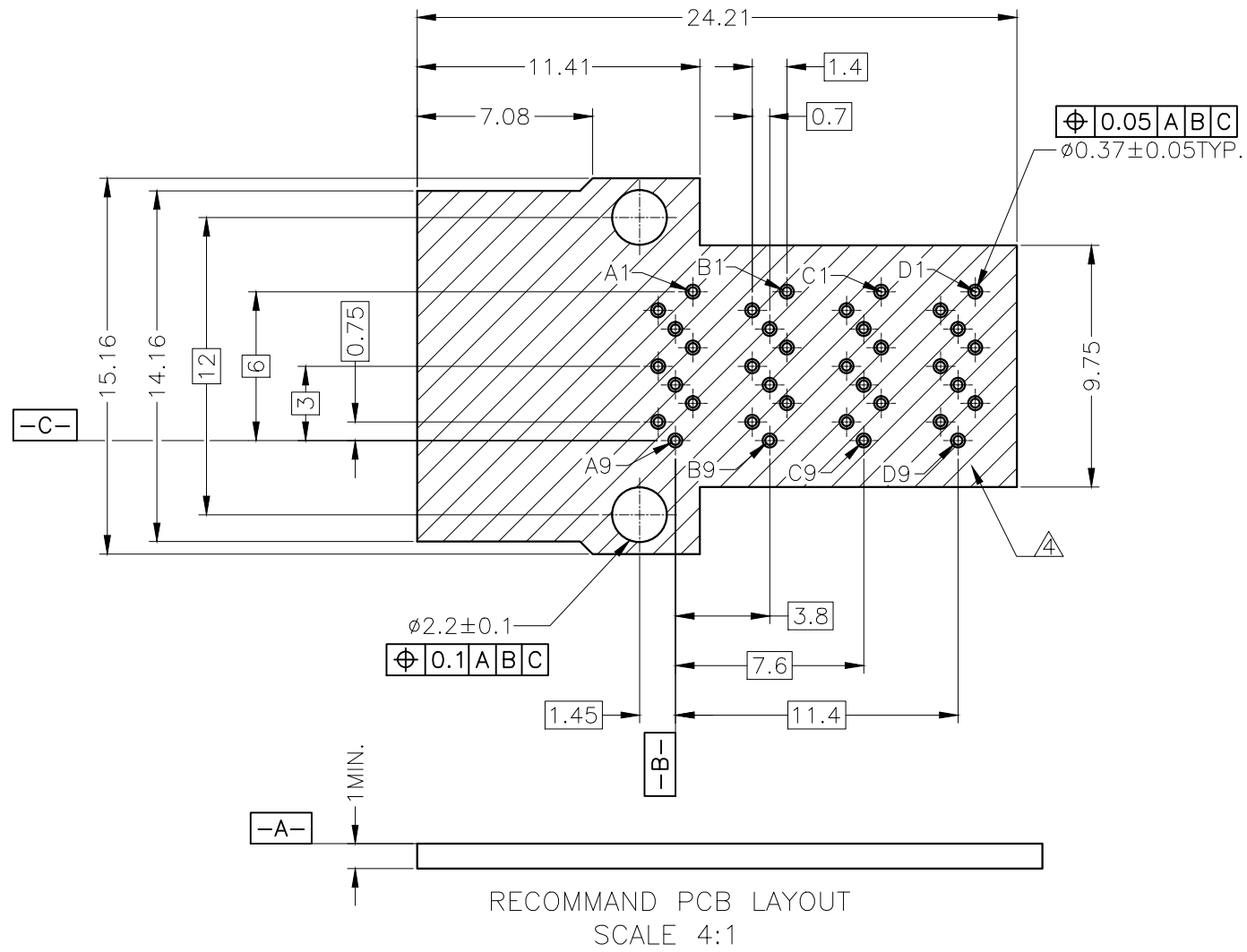

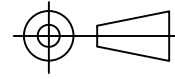
X.±-	X.°±-	PART NO.: PMSB36-1300-000-0H	LUXSHARE-ICT			
.X±-	.X°±-					
.XX±-	.XX°±-	TITLE: MINI-SAS HD CONNECTIR 1X1(12G)	CUSTOMER P/N: -			
.XXX±	.XXX°±-					
UNITS:	mm	APPD: -	DWG NO: PMSB36-1300-000-0H-00			
THESE DRAWINGS AND SPECIFICATIONS ARE THE PROPERTY OF LUXSHARE-ICT AND SHALL NOT BE REPRODUCED, COPIED OR CUED IN ANY MANNER WITHOUT THE PRIOR WRITTEN CONSENT OF LUXSHARE-ICT		CHKD: -		SCALE	SHEET	REV.
		DRAW: -		4:1	2 OF 2	X2