

# Exascend eMMC5.1 Specification

---

## EM300 Series

## Revision History

Version	Date	Description
001	23-Jul	First Released
002	23-Set	Add Warranty

# Table of Contents

<b>1. Description</b> .....	<b>4</b>
<b>2. Product List</b> .....	<b>4</b>
<b>3. Features</b> .....	<b>5</b>
<b>4. Functional Block Diagram</b> .....	<b>6</b>
<b>5. eMMC Device and System</b> .....	<b>7</b>
5.1 eMMC System Overview .....	7
5.2 eMMC Device Overview .....	7
<b>6. eMMC 5.1 Feature Overview</b> .....	<b>9</b>
6.1 Boot.....	9
6.2 Sleep (CMD5) .....	9
6.3 Bus Modes.....	9
6.4 Reliable Write.....	10
6.5 Secure Erase .....	10
6.6 Secure Trim .....	11
6.7 Trim .....	11
6.8 Partition Management.....	11
6.9 High priority interrupt (HPI) .....	12
6.10 Background Operations .....	12
6.11 H/W Reset.....	12
6.12 Packed Commands .....	12
6.13 Cache .....	12
6-14 Discard .....	13
6-15 Sanitize.....	13
6-16 Dynamic Capacity Management.....	13
<b>7. Product Specifications</b> .....	<b>14</b>
7-1 Power Consumption .....	14
7-2 Performance .....	14
7-3 Operating Conditions.....	14
7-4 Physical Specification.....	15
<b>8. Interface Description</b> .....	<b>17</b>
8-1 eMMC Interface ball array.....	17
8-2 Pins and Signal Description .....	18
<b>9. Device Resistors</b> .....	<b>19</b>
9.1 Operating Condition Resistor (OCR) .....	19
9.2 Card Identification Resistor (CID) .....	19
9-3 Card Specific Data Resistor (CSD) .....	20
9-4 Extended CSD Resistor.....	22
<b>Legal information</b> .....	<b>32</b>
Limited Warranty Policy .....	32
Warranty Terms.....	32
Disclaimer of liability .....	32
Copyright notice.....	33
Contact information.....	33

## 1. Description

Exascend eMMC is an embedded flash memory storage solution.

Exascend eMMC is a hybrid device combining an embedded flash controller include LDPC based ECC and flash memory, with JEDEC Standard eMMC 5.1 interface.

The eMMC controller include LDPC based ECC directs the Flash management, including ECC, wear-leveling, IOPS optimization and read sensing, significantly reducing the storage management burden of the host CPU.

eMMC is an ideal storage solution for many electronics devices. eMMC designed to cover a wide area of application such as smart phones, Tablet PCs, Mobile phones, PDAs, Handheld electronics, Digital video cameras, Multimedia equipment, etc. Not only used in consumer products, eMMC is being adopted rapidly in embedded applications, such as many Computer on Module designs, because of its compact size, low power consumption and many enhanced feature.

The technology specifications of eMMC are managed by JEDEC, the global leader in developing open standards for the microelectronics industry.

## 2. Product List

Density	Part Number	Package	PKG size (mm)	Remark
4GB	ESEMSA004GQBG-I	FBGA153	11.5 x 13.0 x 1.0	1 stack
8GB	ESEMSA008GQBG-I	FBGA153	11.5 x 13.0 x 1.0	1 stack
16GB	ESEMSA016GYBG-I	FBGA153	11.5 x 13.0 x 1.0	1 stack
32GB	ESEMSA032GYBG-I	FBGA153	11.5 x 13.0 x 1.0	1 stack
64GB	ESEMSA064GYBG-I	FBGA153	11.5 x 13.0 x 1.0	1 stack
128GB	ESEMSA128GYBG-I	FBGA153	11.5 x 13.0 x 1.0	2 stack

\*4~8GB with MLC solution / 16GB~128GB with 3D TLC solution

## 3. Features

- Support JEDEC/ eMMC 5.1 Compliant
  - Support 3.3V/1.8V power supply
  - Support 12 wire bus (CLK, CMD, Data Strobe, DAT[7:0] and hardware reset (RST\_n))
  - Up to 400MHz clock speed
  - Support Single Data Rate(SDR) and Dual Data Rate(DDR)
  - Support different Bus width : 1bit, 4bit, 8bit
  - Support Original Boot and Alternative Boot modes
  - Support Data Removal (Erase, Trim and Sanitize)
  - Support Replay Protected Memory Block(RPMB)
  - Support Multiple Partitions with enhanced attribute
  - Support Lock/Unlock and Write Protection
  - Support Data Protection for Power Failure
  - Support Power Saving Sleep Mode
  - Support High Priority Interrupt(HPI)
  - Support Background Operation
  - Support Packed Commands
  - Support Sampling Tuning Sequence
  - Support Dynamic Power Manager : standby and sleep modes
  - Support Command Queuing
  - Support Secure Write Protection
- 
- **Package size**
    - 11.5mm x 13.0mm x 1.0mm
- 
- **Operating Voltage range**
    - $V_{CC} = 2.7V \sim 3.6V$  (typical 3.3V)
    - $V_{CCQ} = 1.7V \sim 1.95V$ (typical 1.8V),  $2.7V \sim 3.6V$  (typical 3.3V)
- 
- **Temperature**
    - Operating :  $-40^{\circ}C \sim 85^{\circ}C$
    - Storage :  $-50^{\circ}C \sim 95^{\circ}C$

## 4. Functional Block Diagram

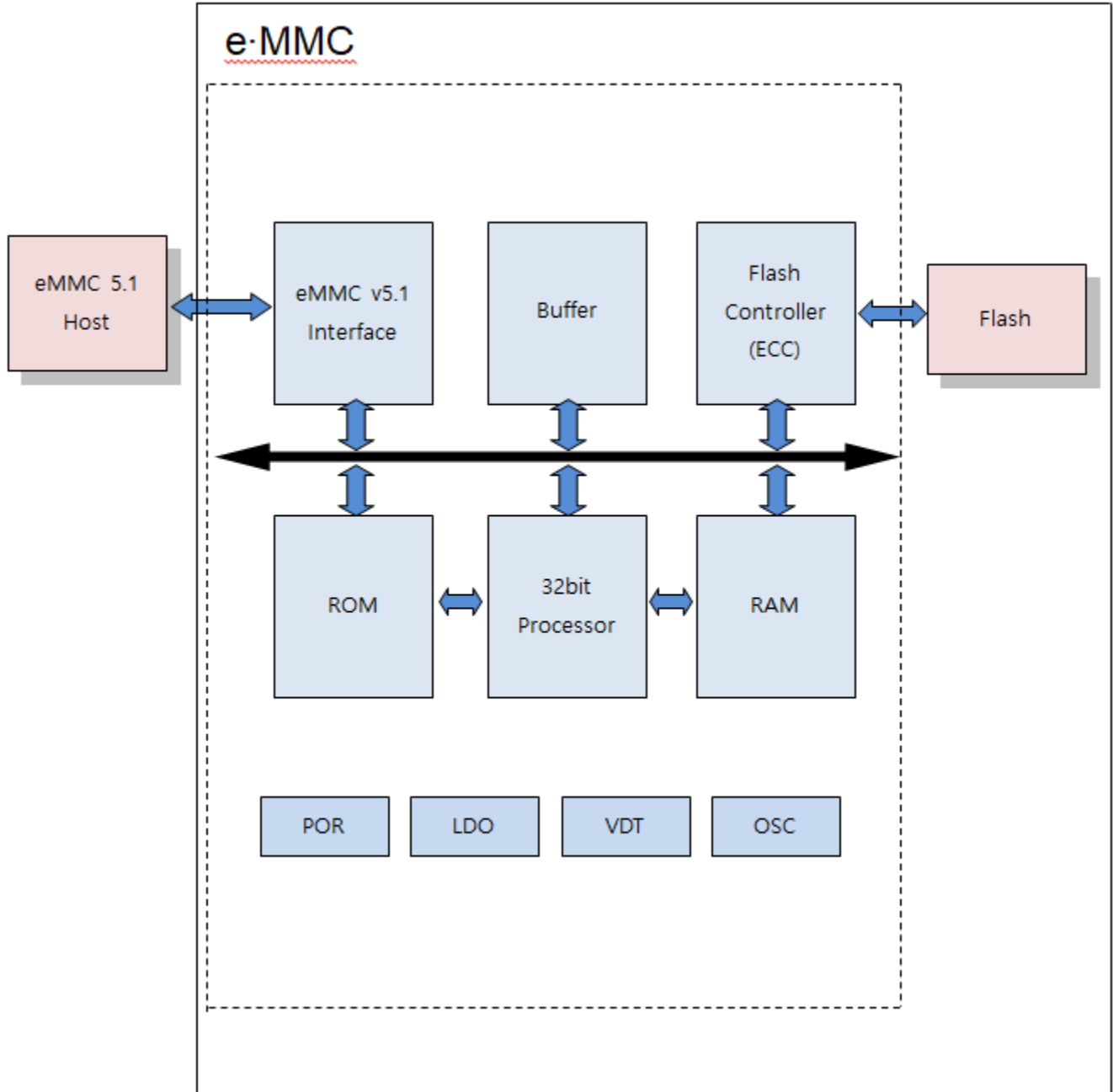

Figure 1 - eMMC Block Diagram

## 5. eMMC Device and System

### 5.1 eMMC System Overview

The eMMC specification covers the behavior of the interface and the device controller include LDPC based ECC. AS part of this specification the existence of a host controller include LDPC based ECC and a memory storage array are implied but the operation of these pieces is not fully specified

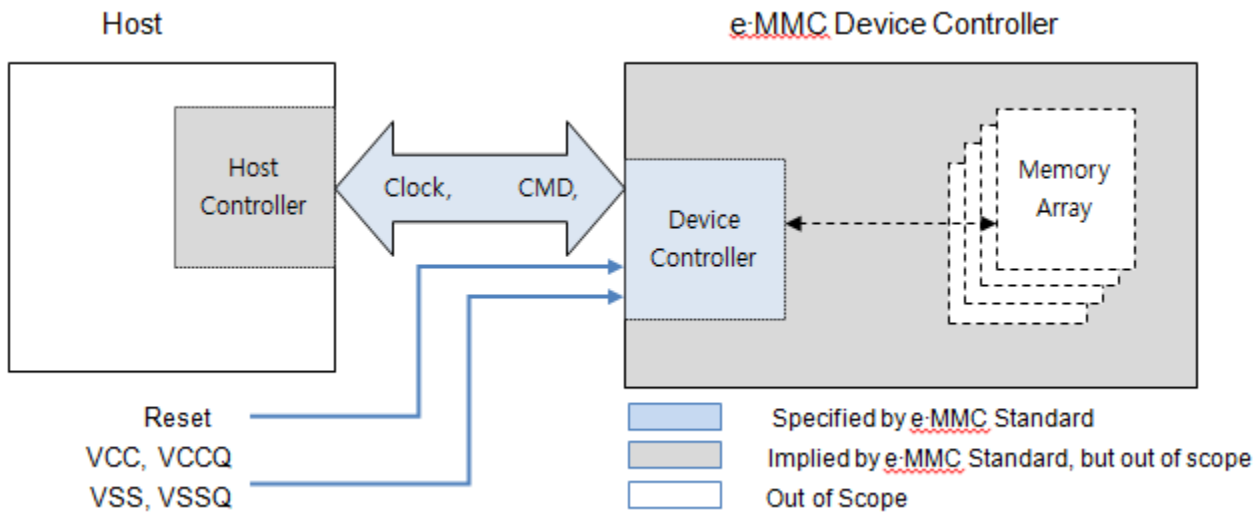

Figure 2 - eMMC System Overview

### 5.2 eMMC Device Overview

The eMMC bus has the following communication and power lines

- CLK : Clock Input
- DS : Data strobe used for output in HS400 mode.
- CMD : Command is a bidirectional signal. The host and eMMC operate in two modes, open drain and push-pull
- DAT0~DAT7 : Data lines are bidirectional signal. Host and eMMC operate in push-pull mode.
- RST\_n : Hardware Reset Input
- VCC : VCC is the power supply for core and flash IO.
- VCCQ : VCCQ is the power supply line for host interface
- VSS, VSSQ : Ground lines.

**Table 1 - eMMC Interface**

Name	Type	Description
CLK	I	Clock
DS	O/PP	Data Strobe
DAT0	I/O/PP	Data
DAT1	I/O/PP	Data
DAT2	I/O/PP	Data
DAT3	I/O/PP	Data
DAT4	I/O/PP	Data
DAT5	I/O/PP	Data
DAT6	I/O/PP	Data
DAT7	I/O/PP	Data
CMD	I/O/PP/OD	Command/Response
RST_n	I	Hardware reset
VCC	S	Supply voltage for Core
VCCQ	S	Supply voltage for I/O
VSS	S	Supply voltage ground for Core
VSSQ	S	Supply voltage ground for I/O
I: input, O: output, PP: push-pull, OD: open-drain, NC: Not connected, S: power supply		

**Table 2 - eMMC registers**

Name	Width	Description	Implementation
	(bytes)		
CID	16	Device Identification number, an individual number for Identification.	Mandatory
RCA	2	Relative Device Address, is the device system address, Dynamically assigned by the host during initialization.	Mandatory
DSR	2	Driver stage Resister, to configure the Device's output drivers.	Optional
CSD	16	Device Specific Data, information about the Device operation conditions.	Mandatory
OCR	4	Operation Conditions Resister. Used by a special broadcast command to identify the voltage type of the Device.	Mandatory
EXT_CSD	512	Extended Device Specific Data. Contains information about the Device capabilities and selected modes.  Introduced in standard v4.0	Mandatory



## **6. eMMC 5.1 Feature Overview**

### **6.1 Boot**

eMMC supports JESD84-B51A boot operation mode, both mandatory as well as alternate mode are supported.

### **6.2 Sleep (CMD5)**

A Device may be switched between a Sleep state and a Standby state by SLEEP/AWAKE(CMD5). In the Sleep State the power consumption of the memory device is minimized. In this state the memory device reacts only to the commands RESET(CMD0 with argument of either 0x00000000 or 0xF0F0F0F0 or H/W reset) and SLEEP/AWAKE(CMD5). All the other commands are ignored by the memory device.

The Vcc power supply may be switched off in Sleep state is to enable even further system power consumption saving.

\*For additional information please refer JESD84-B51A.

### **6.3 Bus Modes**

- **Boot mode**
  - The device will be in boot mode after power cycle, reception of CMD0 with argument of 0xF0F0F0F0 or the assertion of hardware reset signal.
- **Device identification mode**
  - The device will be in device identification mode after boot operation mode is finished or if host and/or device does not support boot operation mode. The device will be in this mode, until the SET\_RCA command (CMD3) is received.
- **Interrupt mode**
  - Host and device enter and exit interrupt mode simultaneously. In interrupt mode there is no data transfer. The only message allowed is an interrupt service request from the device or the host.
- **Data transfer mode**
  - The device will enter data transfer mode once an RCA is assigned to it. The host will enter data transfer mode after identifying the device on the bus
- **Inactive mode**
  - The device will enter inactive mode if either the device operating voltage range or access mode is not valid. The device can also enter inactive mode with GO\_INACTIVE\_STATE command(CMD15). The device will reset to Pre-idle state with power cycle.

**Table 3 - Bus mode's overview**

Device State	Operation mode	Bus mode
Inactive State	Inactive mode	Open-drain
Pre-Idle State	Boot mode	
Pre-Boot State		
Idle State	Device identification mode	
Identification State		
Stand-by State		
Sleep State	Data transfer mode	Push-pull
Transfer State		
Bus-Test State		
Sending-data State		
Receive-data State		
Programming State		
Disconnect State		
Boot State		
Wait-IRQ State	Interrupt mode	Open-drain

## 6.4 Reliable Write

eMMC supports 512B reliable write as defined in eMMC 5.1 spec.

Reliable write is a special write mode in which the old data pointed to by a logical address must remain unchanged until the new data written to same logical address has been successfully programmed. This is to ensure that the target address updated by the reliable write transaction never contains undefined data. When writing reliable write, data will remain valid even if a sudden power loss occurs during programming.

## 6.5 Secure Erase

In addition to the standard Erase command the eMMC support the optional Secure erase command.

The Secure Erase command differs from the basic Erase command in that it requires the device and host to wait until the operation is complete before moving to the next device operation.

\*For additional information please refer JESD84-B51A.

The secure erase command requires device to perform a secure purge operation on the erase groups, and copy items identified for erase, in those erase groups.

A purge operation is defined as overwriting addressable location with a single character and the performing an erase.

This new command meets high security application requirements that once data has been erased, it can no longer be retrieved from device.

## 6.6 Secure Trim

The Secure Trim command is very similar to the Secure Erase command. The Secure Trim command performs a secure purge operation on write blocks instead of erase groups. To minimize the impact on the device’s performance and reliability the Secure Trim operation is completed by executing two distinct steps.

\*For additional information please refer JESD84-B51A.

## 6.7 Trim

The Trim function is similar to the Erase command but applies the erase operation to write blocks instead of erase groups.

\*For additional information please refer JESD84-B51A.

## 6.8 Partition Management

The default area of the memory device consists of a User Data Area to store data, two possible boot area partitions for booting and the Replay Protected Memory Block Area Partition to manage data in an authenticated and replay protected manner. The memory configuration initially consists (before any partitioning operation) of the User Data Area and RPMB Area Partitions and Boot Area Partitions.

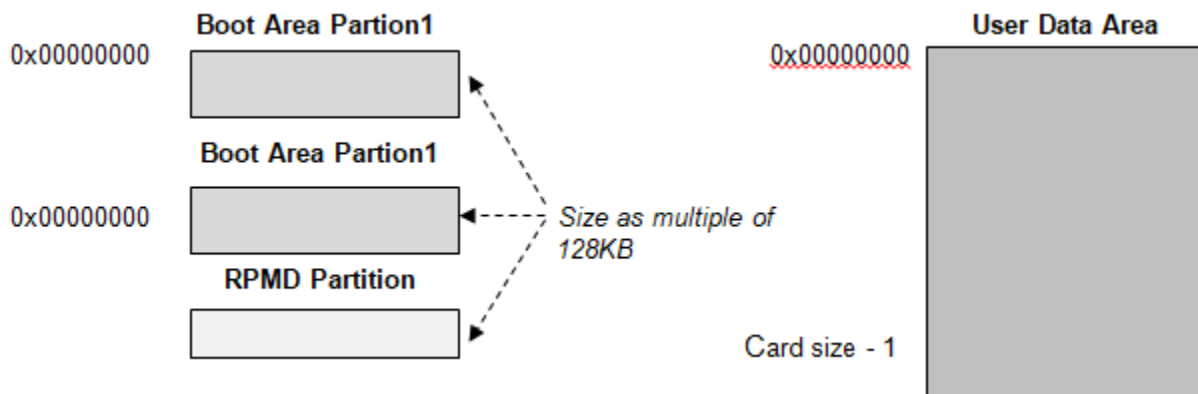

**Figure 3 - eMMC memory organization at time zero**

\*For additional information please refer JESD84-B51A.

## 6.9 High priority interrupt (HPI)

Many operating systems use demand-paging to launch a process requested by the user. If the host needs to fetch pages while in a middle of a write operation, the request will be delayed until the completion of the write command which, in the worst case scenario, can take up to 350ms.

The high priority interrupt (HPI) as defined in JESD84-B51A enables low read latency operation by suspending a lower priority operation before it is actually completed. This mechanism can reduce read latency, in typical condition, to 5msec

\*For additional information please refer JESD84-B51A.

## 6.10 Background Operations

Devices have various maintenance operations that they need to perform internally, such as garbage collection, erase and compaction. In order to reduce latencies during time critical operations, it is better to execute maintenance operations when the device is not serving the host.

Operations are then separated into two types: foreground operations – such as read or write command, and background operations- operations that the device can execute when the host is not being served.

\*For additional information please refer JESD84-B51A.

## 6.11 H/W Reset

Hardware reset may be used by host to reset the device, moving the card to a Pre-Idle state and disabling the power-on period write protect on blocks that was set as power-on write protect before the reset was asserted.

\*For additional information please refer JESD84-B51A.

## 6.12 Packed Commands

Read and write commands can be packed in groups of commands (either all read or all write) that transfer the data for all commands in the group in one transfer on the bus to reduce overheads.

\*For additional information please refer JESD84-B51A.

## 6.13 Cache

Cache is temporary storage space in an eMMC device. The cache should in typical case reduce the access time (compared to an access to the main non-volatile) for both write and read. The cache is not directly accessible by the host. This temporary storage space may be utilized also for some

implementation specific operations like as an execution memory for the memory controller include LDPC based ECC and/or as storage for an address mapping table etc but which definition is out of scope of this specification.

\*For additional information please refer JESD84-B51A.

## 6-14 Discard

The Discard is similar operation to TRIM. The Discard function allows the host to identify data that is no longer required so that the device can erase the data if necessary during background erase events. The contents of a write block where the discard function has been applied shall be 'don't care'. After discard operation, the original data may be remained partially or fully accessible to the host dependent on device. The portions of data that are no longer accessible by the host may be removed or unmapped just as in the case of TRIM. The device will decide the contents of discarded write block.

\*For additional information please refer JESD84-B51A.

## 6-15 Sanitize

The sanitize operation is a feature, in addition to TRIM and Erase that is used to remove data from the device. The use of the Sanitize operation requires the device to physically remove data from the unmapped user address space. A Sanitize operation is initiated by writing a value to the extended CSD[165] SANITIZE\_START.

\*For additional information please refer JESD84-B51A.

## 6-16 Dynamic Capacity Management

Extensive memory usage and aging of Flash could result in bad block.

Dynamic Capacity Management provides a mechanism for the memory device to reduce its reported capacity and extend the device life time.

The mechanism to manipulate dynamic capacity is based on: memory array partitioning and the granularity of WP groups. Reducing the capacity is done by releasing of WP-groups anywhere within the address space of the user area. A released WP-Group will behave as a permanently write protected group and it shall not be read from: Writing to an address within a released WP-Group returns a WP error; Reading from an address within a released WP-Group is forbidden and may return an error; Checking write protection (using CMD30) and write protect type (using CMD31) shall report protected groups and permanent write protection accordingly.

\*For additional information please refer JESD84-B51A.

## 7. Product Specifications

### 7-1 Power Consumption

Table 4 - Power Consumption (Ta=25°C @VCC=3.3V & VCCQ=1.8V)

Power Consumption	4GB	8GB	16GB	32GB	64GB	128GB	Units
Standby (VCCQ & VCC on)	150	80	135	135	140	110	uA
Sleep (VCCQ on, VCC off)	120	70	130	130	135	80	uA
HS400 Read VCC	40	70	40	40	40	75	mA
HS400 Read VCCQ	170	200	120	120	125	125	mA
HS400 Write VCC	20	45	50	50	55	85	mA
HS400 Write VCCQ	100	125	65	65	65	70	mA

### 7-2 Performance

Table 5 – Performance

HS400 Performance	4GB	8GB	16GB	32GB	64GB	128GB	Units
Sequential Read	160	250	290	290	295	282	MB/s
Sequential Write	52	115	195	195	190	197	MB/s
Random Read	4200	3900	8200	8200	7900	7560	IOPS
Random Write	3200	4400	7100	7000	6800	5860	IOPS

### 7-3 Operating Conditions

Table 6 - Operating and Storage Temperature

	Temperature	Remark
Operating	-40°C ~ 85°C	None
Non-Operating	-50°C ~ 95°C	None

## 7-4 Physical Specification

eMMC is a 153pin, thin fine-pitched ball grid array.(BGA)

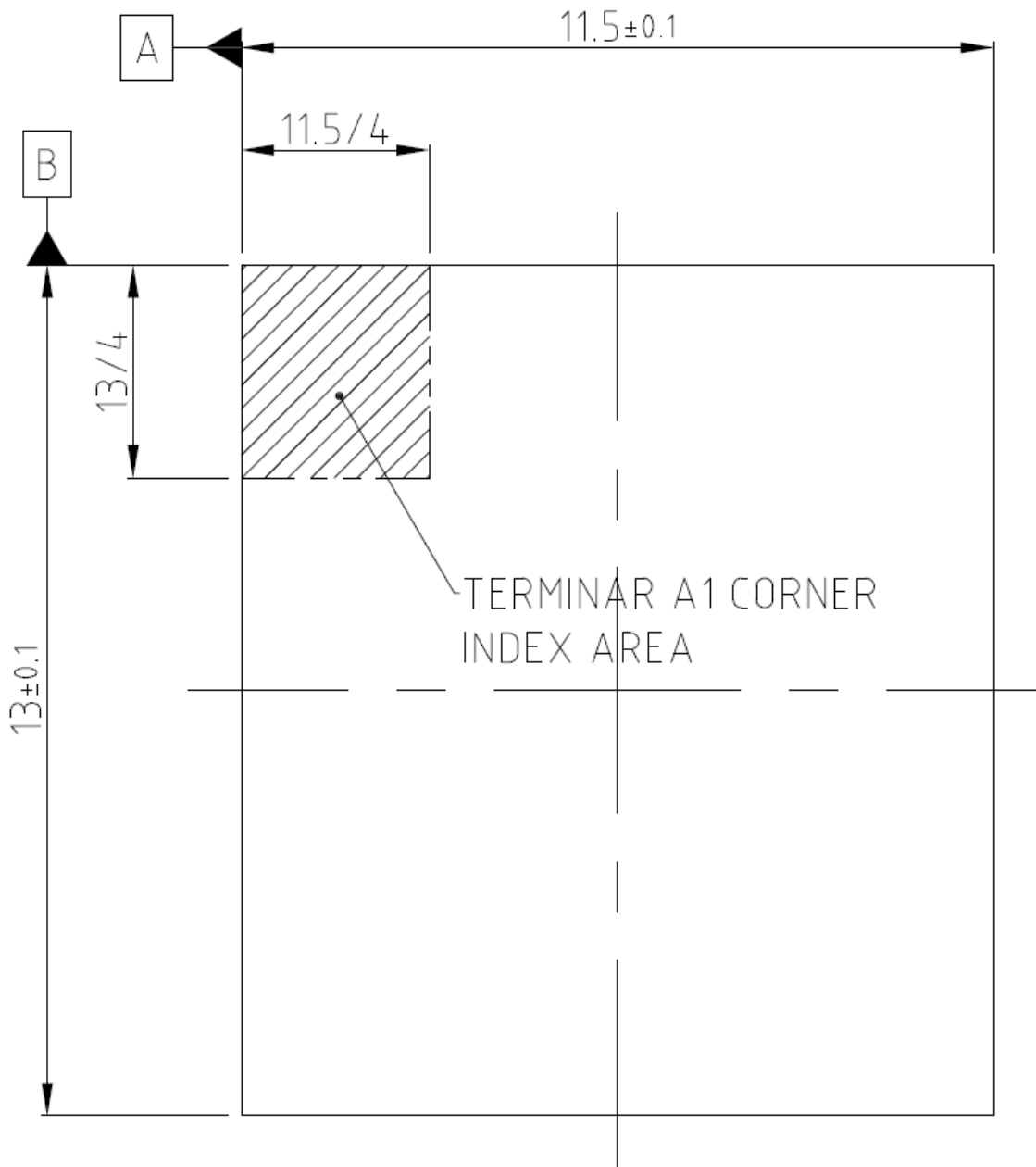
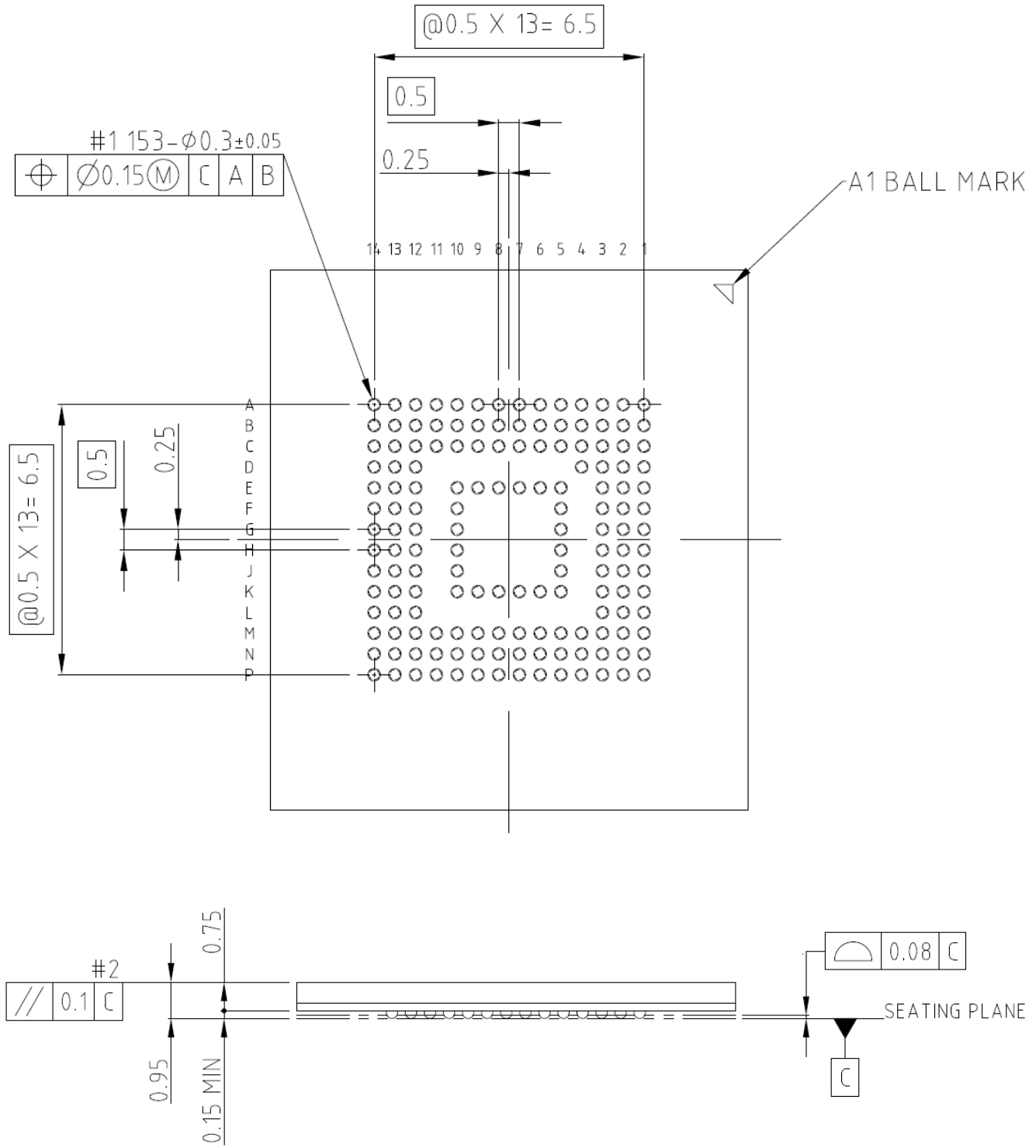

Figure 4 – 11.5 x 13.0 x 1.0mm Top View



**Figure 5 – 11.5 x 13.0 x 1.0mm Bottom & side View**



## 8. Interface Description

### 8-1 eMMC Interface ball array

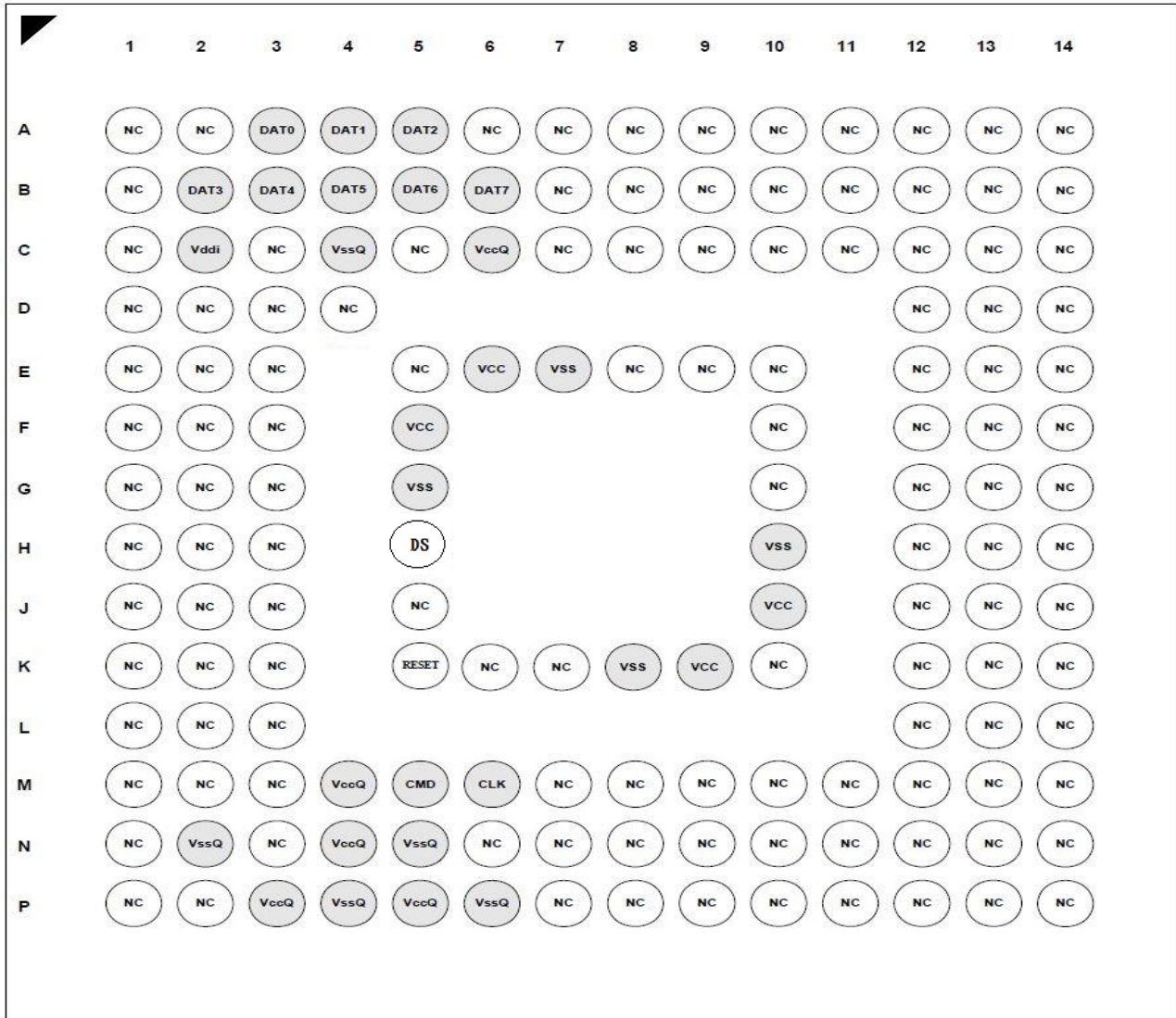

Figure 6 - FBGA153 Package Connection (top view through package)

## 8-2 Pins and Signal Description

**Table 7 – Pin and signal Description**

153-Ball Device	Symbol	Type	Ball Function
M6	CLK	Input	Clock: Each cycle directs a 1-bit transfer on the com-mand and DAT lines.
M5	CMD	Input	Command: A bidirectional channel used for device initiali-zation and command transfer. Command has two operating mode : 1) Open-drain for initialization. 2) Push-pull for fast command transfer.
A3	DAT0	I/O	Data I/O0: Bidirectional channel used for data transfer.
A4	DAT1	I/O	Data I/O1: Bidirectional channel used for data transfer.
A5	DAT2	I/O	Data I/O2: Bidirectional channel used for data transfer.
B2	DAT3	I/O	Data I/O3: Bidirectional channel used for data transfer.
B3	DAT4	I/O	Data I/O4: Bidirectional channel used for data transfer.
B4	DAT5	I/O	Data I/O5: Bidirectional channel used for data transfer.
B5	DAT6	I/O	Data I/O6: Bidirectional channel used for data transfer.
B6	DAT7	I/O	Data I/O7: Bidirectional channel used for data transfer.
K5	RST_n	Input	Reset signal pin
E6, F5, J10, K9	VCC	Supply	VCC: Flash memory I/F and Flash memory power supply.
C6, M4, N4, P3, P5	VccQ	Supply	VccQ: Memory controller core and MMC interface I/O power supply.
E7, G5, H10, K8	VSS	Supply	Vss: Flash memory I/F and Flash memory ground connection.
C4, N2, N5, P4, P6	VssQ	Supply	VssQ
C2	VDDi		VDDi :

			Connect 1uF capacitor from VDDi to ground.
H5	DS		Data Strobe :
			Return clock signal used in HS400 mode

## 9. Device Resistors

### 9.1 Operating Condition Resistor (OCR)

The 32-bit operation condition register(OCR) store the Vdd voltage profile of the eMMC and the access mode indication. In addition, this register includes a status information bit. This status bit is set if the eMMC power up procedure has been finished. The OCR register shall be implemented by eMMC.

**Table 8 - OCR register definition**

OCR bit	Description	Value	Remark
[6:0]	Reserved	000 0000b	
[7]	1.70 ~ 1.95V	1b	
[14:8]	2.0 ~ 2.6V	000 0000b	
[23:15]	2.7 ~ 3.6V	1 1111 1111b	
[28:24]	Reserved	0 0000b	
[30:29]	Access mode	10b	
[31]	card power up status bit (busy) <sup>1</sup>		

<sup>1</sup>This bit is set to LOW if the Device has not finished the power up routine.

### 9.2 Card Identification Resister (CID)

The Card Identification(CID) register is 128 bits wide. In contains the Device identification information used during the Device identification phase(eMMC protocol). Every individual flash or I/O Device shall have an unique identification number. Table 21 lists these identifiers.

The structure of the CID register is defined in the following section.

**Table 9 - Card Identification register definition**

Name	Field	Width	CID-Slice	CID Value	Remark
Manufacture ID	MID	8	[127:120]	FFh	
Reserved		6	[119:114]		
Card / BGA	CBX	2	[113:112]	01h	BGA
OEM/Application ID	OID	8	[111:104]	FFh	Not fixed

Product name	PNM	48	[103:56]	FFFFFF	
Product revision	PRV	8	[55:48]	FF	Not fixed
Product serial number	PSN	32	[47:16]	Random by Production	Not fixed
Manufacturing date	MDT	8	[15:8]	month , year	Not fixed
CRC7 checksum	CRC	7	[7:1]	0h	Not fixed
Not used, always '1'	-	1	[0:0]	0h	

### 9-3 Card Specific Data Resister (CSD)

The Device-specific Data (CSD) register provides information on how to access the Device contents. The CSD defines the data format, error correction type, maximum data access time, data transfer speed, whether the DSR register can be used etc. The programmable part of the register(entries marked by W or E, see below) can be changed by CMD27. The type of the CSD Registry entries below is coded as follows :

- R : Read only
- W : One time programmable and not readable.
- R/W : One time programmable and readable
- W/E : Multiple writable with value kept after power failure, H/W reset assertion and any CMD0 reset and not readable.
- R/W/E : Multiple writable with value kept after power failure, H/W reset assertion and any CMD0 reset and not readable.
- R/W/C\_P : Writeable after value cleared by power failure and H/W reset assertion (the value not cleared by CMD0 reset) and readable.
- R/W/E\_P : Multiple writable with value reset after power failure, H/W reset assertion and any CMD0 reset and readable.
- W/E\_P : Multiple writable with value reset power failure, H/W reset assertion and any CMD0 reset and not readable.

**Table 10 - CSD Field**

Name	Field	Width	Cell type	CSD Slice	CSD Value	Remark
CSD structure	CSD_STRUCTURE	2	R	[127:126]	3h	
System Specification version	SPEC_VERS	4	R	[125:122]	4h	
Reserved	-	2	R	[121:120]		
Data read access-time 1	TAAC	8	R	[119:112]	2Fh	20ms
Data read access-time 2in CLK cycle (NSAC*100)	NSAC	8	R	[111:104]	1h	
Max. bus clock frequency	TRAN_SPEED	8	R	[103:96]	2Ah	20MHz
Device command classes	CCC	12	R	[95:84]	5F5h	Class 0,2,4,5,6,7,8,10
Max. read data block length	READ_BL_LEN	4	R	[83:80]	9h	512B

Partial blocks for read allowed	READ_BLK_PARTIAL	1	R	[79:79]	0h	Not support
Write block misalignment	WRITE_BLK_MISALIGN	1	R	[78:78]	0h	Not support
Name	Field	Width	Cell type	CSD Slice	CSD Value	Remark
Read block misalignment	READ_BLK_MISALIGN	1	R	[77:77]	0h	Not support
DSR implemented	DSR_IMP	1	R	[76:76]	0h	Not support
Reserved		2	R	[75:74]		
Device size	C_SIZE	12	R	[73:62]	FFFh	
Max read current @VDD min	VDD_R_CURR_MIN	3	R	[61:59]	6h	
Max read current @VDD max	VDD_R_CURR_MAX	3	R	[58:56]	6h	
Max write current @VDD min	VDD_W_CURR_MIN	3	R	[53:53]	6h	
Max write current @VDD max	VDD_W_CURR_MAX	3	R	[52:50]	6h	
Device size multiplier	C_SIZE_MULT	3	R	[49:47]	7h	
Erase group size	ERASE_GRP_SIZE	5	R	[46:42]	1Fh	
Erase group size multiplier	ERASE_GRP_MULT	5	R	[41:37]	1Fh	
Write protect group size	WP_GRP_SIZE	5	R	[36:32]	1h	
Write protect group enable	WP_GRP_ENABLE	1	R	[31:31]	1h	
Manufacturer default ECC	DEFAULT_ECC	2	R	[30:29]	0h	
Write speed factor	R2W_FACTOR	3	R	[28:26]	1h	
Max. write data block length	WRITE_BLK_LEN	4	R	[25:22]	9h	512B
Partial blocks for write allowed	WRITE_BLK_PARTIAL	1	R	[21:21]	0h	Not support
Reserved		4	R	[20:17]		
Content protection application	CONTENT_PROT_APP	1	R	[16:16]	0h	Not support
File format group	FILE_FORMAT_GRP	1	R/W	[15:15]	0h	
Copy flag (OTP)	COPY	1	R/W	[14:14]	0h	
Permanent write protection	PERM_WRITE_PROTECT	1	R/W	[13:13]	0h	
Temporary write protection	TMP_WRITE_PROTECT	1	R/W/E	[12:12]	0h	
File format	FILE_FORMAT	2	R/W	[11:10]	0h	
ECC code	ECC	2	R/W/E	[9:8]	0h	None
CRC	CRC	7	R/W/E	[7:1]	Dh	
Not used, always '1'		1	-	[0:0]	1h	

\*The following sections describe the CSD fields and the relevant data types. If not explicitly defined otherwise, all bit strings are interpreted as binary coded numbers starting with the left bit first.

## 9-4 Extended CSD Resister

The Extended CSD register defines the Device properties and selected modes. It is 512bytes long. The most significant 320bytes are the Properties segment, which defines the Device capabilities and cannot be modified by the host. The lower 192bytes are the Modes segment, which defines the configuration the Device is working in. These modes can be changed by the host means of the SWITCH command.

\*For details, refer to section 7.4 of the JEDEC Standard Specification No. JESD84-B51A.

**Table 11 - Extended CSD Field**

Name	Field	Cell type	CSD Slice	EXT_CSD Value	Remark
Properties Segment					
Reserved <sub>1</sub>	RESERVED	TBD	[511:506]		
Extended Security Command Error	EXT_SECURITY_ERR	R	[505]	0h	Only for eMMC4.5 by JESD84-B51A
Supported Command Sets	S_CMD_SET	R	[504]	1h	Allocated by MMCA
HPI features	HPI_FEATURES	R	[503]	3h	Bit[1]=1: HPI mechanism implementation base on CMD12  Bit[1]=0: HPI mechanism implementation base on CMD13  Bit[0]=1: HPI mechanism support  Bit[0]=0: HPI mechanism not support (default)
Background operations support	BKOPS_SUPPORT	R	[502]	1h	Background operation are supported
Max packed read commands	MAX_PACKED_READS	R	[501]	3Fh	
Max packed write commands	MAX_PACKED_WRITES	R	[500]	3Fh	
Data Tag Support	DATA_TAG_SUPPORT	R	[499]	1h	System data tag supported
Tag Unit Size	TAG_UNIT_SIZE	R	[498]	1h	1024Bytes
Tag Resources Size	TAG_RES_SIZE	R	[497]	0h	

Context Management Capabilities	CONTEXT_CAPABILITIES	R	[496]	5h	
Large Unit Size	LARGE_UNIT_SIZE_M1	R	[495]	0h	
Extended partition Attribute Support	EXT_SUPPORT	R	[494]	3h	
Supported modes	SUPPORTED_MODES	R	[493]	1h	
FFU features	FFU_FEATURES	R	[492]	1h	
Operation codes timeout	OPERATION_CODE_TIMEOUT	R	[491]	17h	
FFU Argument	FFU_ARG	R	[490:487]	0h	
Barrier support	BARRIER_SUPPORT	R	[486]	0h	
Reserved1		TBD	[485:309]		
CMD Queuing Support	CMDQ_SUPPORT	R	[308]	0h	
CMD Queuing Depth	CMDQ_DEPTH	R	[307]	0h	
Reserved1		TBD	[306]		
Number of FW sectors correctly programmed	NUMBER_OF_FW_SECTORS_CORRECTLY_PROGRAMMED	R	[305:302]	0h	
Vendor proprietary health report	VENDOR_PROPRIETARY_HEALTH_REPORT	R	[301:270]	0h	
Device life time estimation type B	DEVICE_LIFE_TIME_EST_TYP_B	R	[269]	1h	
Device life time estimation type A	DEVICE_LIFE_TIME_EST_TYP_A	R	[268]	1h	
Pre EOL information	PRE_EOL_INFO	R	[267]	1h	
Optimal read size	OPTIMAL_READ_SIZE	R	[266]	8h	
Optimal write size	OPTIMAL_WRITE_SIZE	R	[265]	8h	
Optimal trim unit size	OPTIMAL_TRIM_UNIT_SIZE	R	[264]	8h	
Device version	DEVICE_VERSION	R	[263:262]	0h	
Firmware version	FIRMWARE_VERSION	R	[261:254]	---	
Power class for 200MHz, DDR at VCC= 3.6V	PWR_CL_DDR_200_360	R	[253]	0h	
Cache size	CACHE_SIZE	R	[252:249]	100h	
Generic CMD6 timeout	GENERIC_CMD5_TIME	R	[248]	32h	Not defined
Name	Field	Cell type	CSD Slice	EXT_CSD Value	Remark
Power off notification (long)timeout	POWER_OFF_LONG_TIME	R	[247]	3Ch	Not defined

Background operations status	BKOPS_STATUS	R	[246]	0h	Outstanding : No operation required
Number of correctly programmed sectors	CORRECTLY_PRG_SECTORS_NUM	R	[245:242]	0h	
1st initialization time after partitioning	INI_TIMEOUT_AP	R	[241]	1Eh	Initial time out 3s
Cache Flushing Policy	CACHE_FLUSH_POLICY	R	[240]	0h	
Power class for 52MHz, DDR at VCC = 3.6V	PWR_CL_DDR_52_360	R	[239]	0h	
Power class for 52MHz, DDR at VCC = 1.95V	PWR_CL_DDR_52_195	R	[238]	0h	
Power class for 200MHz at VCCQ = 1.95V, VCC = 3.6V	PWR_CL_200_195	R	[237]	0h	
Power class for 200MHz at VCCQ = 1.3V, VCC = 3.6V	PWR_CL_200_130	R	[236]	0h	
Minimum Write Performance for 8bit At 52MHz in DDR mode	MIN_PERF_DDR_W_8_52	R	[235]	0h	
Minimum Read Performance for 8bit At 52MHz in DDR mode	MIN_PERF_DDR_R_8_52	R	[234]	0h	
Reserved <sub>1</sub>	RESERVED	TBD	[233]		
TRIM Multiplier	TRIM_MULT	R	[232]	2h	TRIM Timeout = 300ms*2=600ms
Secure Feature support	SEC_FEATURE_SUPPORT	R	[231]	55h	<ol style="list-style-type: none"> <li>1. Support the sanitize operation</li> <li>2. Support the secure and insecure trim operation</li> <li>3. Support the auto erase on retired defective portion of array</li> <li>4. Secure purge operations are supported</li> </ol>
Secure Erase Multiplier	SEC_ERASE_MULT	R	[230]	1Bh	Secure Erase Timeout= 5.1 sec
Secure TRIM Multiplier	SEC_TRIM_MULT	R	[229]	11h	Secure trim Timeout=



					8.1 sec
Boot information	BOOT_INFO	R	[228]	7h	Bit[2]=1: Device supports high speed timing during boot Bit[1]=1: Device supports dual data rate during boot Bit[0]=1: Device supports alternate boot method Bit[0,1,2]=0: Not supports each feature Bit[7:3]=Reserved
Name	Field	Cell type	CSD Slice	EXT_CSD Value	Remark
Reserved <sub>1</sub>	RESERVED	TBD	[227]		
Boot partition size	BOOT_SIZE_MULT	R	[226]	20h	
Access size	ACC_SIZE	R	[225]	6h	
High-capacity erase unit size	HC_ERASE_GRP_SIZE	R	[224]	1h	
High-capacity erase timeout	ERASE_TIMEOUT_MULT	R	[223]	1h	High Capacity erase timeout : 300ms
Reliable write sector count	REL_WR_SEC_C	R	[222]	1h	1sector
High-capacity write protect group size	HC_WP_GRP_SIZE	R	[221]	20h	
Sleep current (VCC)	S_C_VCC	R	[220]	7h	Sleep Current :128uA
Sleep current(VCCQ)	S_C_VCCQ	R	[219]	7h	Sleep Current :128uA
Production state awareness timeout	PRODUCTION_STATE_AWARENESS_TIMEOUT	R	[218]	17h	
Sleep/awake timeout	S_A_TIMEOUT	R	[217]	17h	Sleep/Awake Timeout : 85ms
Sleep Notification Timeout	SLEEP_NOTIFICATION_TIME	R	[216]	11h	
Sector Count	SEC_COUNT	R	[215:212]	---	
Secure Write Protect Information	SECURE_WP_INFO	TBD	[211]	0h	
Minimum Write Performance for 8bit At 52MHz	MIN_PERF_W_8_52	R	[210]	0h	
Minimum Read Performance for 8bit	MIN_PERF_R_8_52	R	[209]	0h	

At 52MHz					
Minimum Write Performance for 8bit at 26MHz, for 4bit at 52MHz	MIN_PERF_W_8_26_4_52	R	[208]	0h	
Minimum Write Performance for 8bit at 26MHz, for 4bit at 52MHz	MIN_PERF_R_8_26_4_52	R	[207]	0h	
Minimum Write Performance for 4bit at 26MHz	MIN_PERF_W_4_26	R	[206]	0h	
Minimum Write Performance for 4bit at 26MHz	MIN_PERF_R_26	R	[205]	0h	
Reserved <sub>1</sub>	RESERVED	R	[204]		
Power class for 26MHz at 3.6V 1R	PWR_CL_26_360	R	[203]	0h	MAX RMS Current = 100mA, MAX Peak Current = 200mA
Power class for 52MHz at 3.6V 1R	PWR_CL_52_360	R	[202]	0h	MAX RMS Current = 100mA, MAX Peak Current = 200mA
<b>Name</b>	<b>Field</b>	<b>Cell type</b>	<b>CSD Slice</b>	<b>EXT_CSD Value</b>	<b>Remark</b>
Power class for 26MHz at 1.95V 1R	PWR_CL_26_195	R	[201]	0h	MAX RMS Current = 65mA, MAX Peak Current = 130mA
Power class for 52MHz at 1.95V 1R	PWR_CL_52_195	R	[200]	0h	MAX RMS Current = 65mA, MAX Peak Current = 130mA
Partition switching timing	PARTITION_SWITCH_TIME	R	[199]	5h	Partition switch time : 10ms
Out-of-interrupt busy timing	OUT_OF_INTERRUPT_TIME	R	[198]	19h	HPI time out : 20ms
I/O Driver Strength	DRIVER_STRENGTH	R	[197]	Fh	Support driver strength : Type0,1,2,3
Device type	DEVICE_TYPE	R	[196]	57h	1. HS400 @ 1.8V  2. High-speed Data Rate 52@ 1.8V/3.3V

					3. High-speed Data Rate 52@rated device voltage(s)
					4. High-speed Data Rate 26@rated device voltage(s)
Reserved <sub>1</sub>	RESERVED	TBD	[195]		
CSD structure	CSD_STRUCTURE	R	[194]	2h	CSD version No.1.2
Reserved <sub>1</sub>	RESERVED	TBD	[193]		
Extend CSD revision	EXT_CSD_REV	R	[192]	8h	Revision 1.8(for MMC v5.1)
Modes Segment					
Command set	CMD_SET	R/W/E_P	[191]	0h	
Reserved <sub>1</sub>	RESERVED	TBD	[190]		
Command set revision	CMD_SET_REV	R	[189]	0h	V4.0
Reserved <sub>1</sub>	RESERVED	TBD	[188]		
Power class	POWER_CLASS	R/W/E_P	[187]	0h	See EXT_CSD in spec.
Reserved <sub>1</sub>	RESERVED	TBD	[186]		
High-speed interface timing	HS_TIMING	R/W/E_P	[185]	0h	It depends on Host I/F speed. Default is 0, But it can be 1 by host
Strobe Support	STROBE_SUPPORT	R	[184]	1h	
Bus width mode	BUS_WIDTH	W/E_P	[183]	0h	
Reserved <sub>1</sub>	RESERVED		[182]		
Erase memory content	ERASED_MEM_CONT	R	[181]	0h	0 after erase
Name	Field	Cell type	CSD Slice	EXT_CSD Value	Remark
Reserved <sub>1</sub>	RESERVED	TBD	[180]		
Partition configuration	PARTITION_CONFIG	R/W/E & R/W /E_P	[179]	0h	
Boot config protection	BOOT_CONFIG_PROT	R/W/E & R/W /C_P	[178]	0h	
Boot bus Conditions	BOOT_BUS_CONDITIONS	R/W/E	[177]	0h	
Reserved <sub>1</sub>	RESERVED	TBD	[176]		
High-density erase group	ERASE_GROUP_DEF	R	[175]	0h	

definition					
Boot write protection status registers		TBD	[174]	0h	
Boot area write protection register	BOOT_WP	R/W/E & R/W  /C_P	[173]	0h	Bit[6]=0 : Master is permitted to set B_PWR_WP_EN (bit0)  Bit[4]=0 : Master is permitted to set B_PERM_WP_EN (bit2)  Bit[2]=0 : Boot Region is not permanently write protected  Bit[0]=0 : Boot Region is not power-on write protected
Reserved <sub>1</sub>	RESERVED	TBD	[172]		
User area write protection register	USER_WP	R/W, & R/W /C_P & R/W /E_P	[171]	0h	
Reserved <sub>1</sub>	RESERVED	TBD	[170]		
FW configuration	FW_CONFIG	R/W	[169]	0h	FW updates enabled
RPMB Size	RPMB_SIZE_MULT	R	[168]	20h	RPMB size 512KB
Write reliability setting register	WR_REL_SET	R/W	[167]	0h	
Write reliability parameter register	WR_REL_PARAM	R	[166]	14h	1. Enhanced definition of reliable write  2. All the WR_DATA_REL parameter in the WR_REL_SEL register are R/W
<b>Name</b>	<b>Field</b>	<b>Cell type</b>	<b>CSD Slice</b>	<b>EXT_CSD Value</b>	<b>Remark</b>
Start Sanitize operation	SANITIZE_START	W/E_P	[165]	0h	
Manually start background operations	BKOPS_EN	W/E_P	[164]	0h	

Enable background operations handshake	BKOPS_EN	R/W	[163]	0h	
H/W reset function	RST_n_FUNCTION	R/W	[162]	0h	
HPI management	HPI_MGMT	R/W/E_P	[161]	0h	
Partitioning Support	PARTITIONING_SUPPORT	R	[160]	7h	<p>1. Can have extended partitions attribute</p> <p>2. Can have enhanced technological features</p> <p>3. Device supports partitioning features</p>
Max Enhanced Area Size	MAX_ENH_SIZE_MULT	R	[159:157]		
Partitions attribute	PARTITIONS_ATTRUBUTE	R/W	[156]	0h	<p>Bit[7:5]: Reserved</p> <p>Bit[4]=1: Set Enhanced attribute in General Purpose partition 4</p> <p>Bit[3]=1: Set Enhanced attribute in General Purpose partition 3</p> <p>Bit[2]=1: Set Enhanced attribute in General Purpose partition 2</p> <p>Bit[1]=1: Set Enhanced attribute in General Purpose partition 1</p>
Partitioning Setting	PARTITON_SETTING_COMPLETED	R/W	[155]	0h	
General Purpose Partition Size	GP_SIZE_MULT	R/W	[154:143]	0h	
Enhanced User Data Area Size	ENH_SIZE_MULT	R/W	[142:140]	0h	
Enhanced User Data Start Address	ENH_START_ADDR	R/W	[139:136]	0h	
Reserved <sup>1</sup>	RESERVED	TBD	[135]		

Bad Block Management mode	SEC_BAD_BLK_MGMNT	R/W	[134]	0h	
Production state awareness	PRODUCTION_STATE_AWARENESS	R/W/E	[133]	0h	
Name	Field	Cell type	CSD Slice	EXT_CSD Value	Remark
Package Case Temperature is Controlled	TCASE_SUPPORT	W/E_P	[132]	0h	
Periodic Wake-up	PERIODIC_WAKEUP	R/W/E	[131]	0h	
Program CID/CSD in DDR mode Support	PROGRAM_CID_CSD_DDR_SUPPORT	R	[130]	1h	
Reserved <sub>1</sub>	RESERVED	TBD	[129:128]		
Vendor Specific Fields	VENDOR_SPECIFIC_FIELD		[127:64]	0h	
Native sector size	NATIVE_SECTOR_SIZE	R	[63]	0h	
Sector size emulation	USE_NATIVE_SECTOR	R/W	[62]	0h	
Sector size	DATA_SECTOR_SIZE	R	[61]	0h	
1st initialization after disabling sector size emulation	INI_TIMEOUT_EMU	R	[60]	0h	
Class 6 commands control	CLASS_6_CTRL	R/W/E_P	[59]	0h	
Number of addressed group to be Released	DYNCAP_NEEDED	R	[58]	0h	
Exception event control	EXCEPTION_EVENTS_CTRL	R/W/E_P	[57:56]	0h	
Exception event status	EXCEPTION_EVENTS_STATUS	R	[55:54]	0h	
Extended Partitions Attribute	EXT_PARTITIONS_ATTRIBUTE	R/W	[53:52]	0h	
Context configuration	CONTEXT_CONF	R/W/E_P	[51:37]	0h	
Packed command status	PACKED_COMMAND_STATUS	R	[36]	0h	
Packed command failure index	PACKED_FAILURE_INDEX	R	[35]	0h	
Power Off Notification	POWER_OFF_NOTIFICATION	R/W/E_P	[34]	0h	Power off notification is not supported by host, device should not assume any notification
Control to turn the Cache ON/OFF	CACHE_CTRL	R/W/E_P	[33]	0h	
Flushing of the cache	FLUSH_CACHE	W/E_P	[32]	0h	

Control to turn the Barrier ON/OFF	BARRIER_CTRL	R/W	[31]	0h	
Mode config	MODE_CONFIG	R/W/E_P	[30]	0h	
Mode operation codes	MODE_OPERATION_CODES	W/E_P	[29]	0h	
Reserved1		TBD	[28:27]		
FFU status	FFU_STATUS	R	[26]	0h	
Pre loading data size	PRE_LOADING_DATA_SIZE	R/W/E_P	[25:22]	0h	
Max pre loading data size	MAX_PRE_LOADING_DATA_SIZE	R	[21:18]		
Product state awareness enablement	PRODUCT_STATE_AWARENESS_ENABLEMENT	R/W/E & R	[17]	3h	
Secure Removal Type	SECURE_REMOVAL_TYPE	R/W/E & R	[16]	9h	
Command Queue Mode Enable	CMDQ_MODE_EN	R/W/E_P	[15]	0h	
Reserved1		TBD	[14:0]		
NOTE1. Reserved bits should read as “0”					
NOTE2. Obsolete values should be don't care					

## Legal information

### Limited Warranty Policy

Exascend, Inc. ("Exascend") warrants that Exascend's product, in its original sealed packaging, will be free from defects in materials and workmanship. Subject to the conditions and limitations set forth below, Exascend will either repair or replace any part of its products that prove defective by reason of improper workmanship or materials. This warranty is non-transferable and valid only for the original purchaser of the Exascend products, except where prohibited by law. The original sales receipt or invoice, or a copy thereof, is required to establish the purchase date and original purchaser.

1. This warranty supersedes all other warranties and representations, whether oral or written, between you and Exascend. Exascend makes no other warranties, including any warranty of merchantability or fitness for a particular purpose, whether expressly or implied.
2. All warranties, whether express or implied, are limited to the periods of time set forth below. Some states and jurisdictions do not allow such exclusion of implied warranties, limitations or warranty period, so above restrictions may not apply to you.
3. Exascend may acknowledge or read and save the data and information (collectively, "Information") stored in the product during after-services. Exascend hereby agrees that Exascend will not disclose any Information to any third parties, except Exascend's employees, who may need to access the Information, with or without your prior written consent.

### Warranty Terms

We offer three (3) years limited warranty for our eMMC products.

The warranty period is the SHORTER OF:

- a period of three (3) years beginning from the date of purchase; or
- the period ending when the drive reached advertised DWPD or TBW rating; or
- the period ending when the device's Lifespan indicator has reached 0% or below.

This Limited Warranty will not apply to, and Exascend will have no liability or obligation with respect to, problems or damage resulting from any of the following: (i) accident, modification, neglect, abuse, careless or incorrect handling, misuse or improper operation, disassembly, misapplication or use in unusual physical environments or under operating conditions not approved by Exascend (including, but not limited to, use of the Product with an improper voltage supply); (ii) normal wear and tear; (iii) removal of label(s) or sticker(s) provided on or with the Product (including all warranty or quality-control stickers, product serial or electronic numbers); (iv) problems relating to or residing in non-Exascend hardware, software or other items with which the Product is used; (v) use in an environment, in a manner or for a purpose for which the Product was not designed or not in accordance with Exascend's published documentation; (vi) installation, modification, alteration or repair by anyone other than Exascend or its authorized representatives; (vii) problems that do not relate to materials or workmanship or that have an insignificant impairment on the use or operation of the Product; or (viii) problems related to consumables; (ix) Product purchased "AS-IS" or "with known faults, defects or problems." Additionally, Exascend will have no liability or obligation to recover any data in the Product.

### Disclaimer of liability

Exascend, Inc. reserves the right to make changes to specifications and product descriptions such as but not limited to numbers, parameters and other technical information contained herein without notice. Please contact Exascend, Inc. to obtain the latest specifications. Exascend, Inc. grants no warranty with respect to this datasheet, explicit or implied, and is not liable for direct or indirect damages. Some states do not grant the exclusion of incidental damages and as such this statement may not be valid in such states. The provisions of the datasheet do not convey to the purchaser of the device any license under any patent right or other intellectual property right of Exascend, Inc.

### Customers must not use Exascend products in applications where a device failure or malfunction may cause personal injury or death, e.g., in life support systems or devices.

Exascend shall not be liable for any loss, injury or damage caused by use of the products in any of the following applications:

- Medical-related devices, life support, medical measurement devices, etc.
- Control devices for trains, ships, mass transportation systems or automotive vehicles, etc.



- Specific applications including military/defense-related equipment, aerospace, nuclear facility control systems, etc.
- Safety systems for disaster prevention/crime prevention, etc.

### Copyright notice

Copyright © 2023 Exascend, Inc. All rights reserved. Information contained in this document, including but not limited to any instructions, descriptions, and product specifications, is considered proprietary and confidential to Exascend, Inc. and shall not be modified, used, copied, reproduced or disclosed in whole or in part, in any form or by any means, electronic or mechanical, for any purpose, without the written consent of Exascend, Inc.

### Contact information

Exascend Taiwan Office

Address: Room 1, 6F, No.288, Sec. 6, Civic Blvd., Xinyi Dist., Taipei City 110, Taiwan (R.O.C.)

General Support: +886-2-2726-6500

Fax: +886-2-2726-6126

Email: [sales@exascend.com](mailto:sales@exascend.com)

Exascend reserves the right to change  
products or specification without notice.