

1 2 3 4 5 6 7 8 9

F

E

D

C

B

A

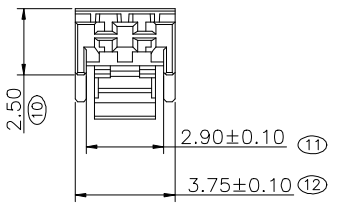
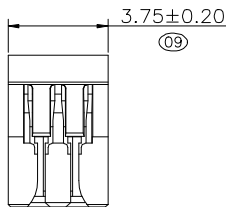
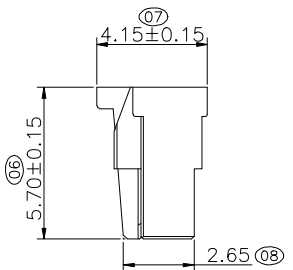
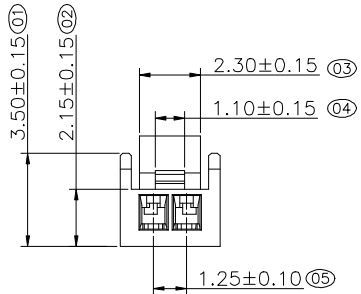

Specifications

Current Rating:AWG26:1.0Amp
:AWG28:1.0Amp
:AWG30:1.0Amp

Voltage Rating: 50V AC/DC.
Insulation Resistance:100MΩ Min.
Dielectric Withstanding Voltage:500V AC
Contact Resistance:30mΩ Max.
Operating Temperature:-25°C to +85°C
Materials

Regular Thermoplastic:Only Suitable for
Wave Soldering Process (PBT).
All materials must meet GREENCONN
hazardous substances control standards.

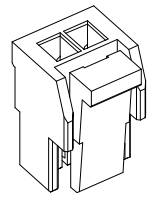

Ordering Information

G HD361 - XX A AJ - N
 No. of Pins per Row Standard Packing
 09 N=PE bag



3RD.ANG
PROJ.

PAGE. 1/1

GENERAL TOLERANCE	
X'±5.0'	X.±0.30
.X'±3.0'	.X±0.25
.XX'±2.0'	.XX±0.15
.XXX'±1.0'	.XXX±0.10

DESIGNED:	DATE:
CHECKED:	DATE:
APPROVED:	DATE:

DWG. NO.
GHD361-HA-N
 PART NO.
GHD361-02AAJ-N

TITLE.
1.25mm PITCH
DISCONNECTABLE CRIMP STYLE
CONNECTORS-Housing

REV. A	UNIT. mm	SCALE. 4:1
--------	----------	------------

1 2 3 4 5 6 7 8 9

1 2 3 4 5 6 7 8 9

F

E

D

C

B

A

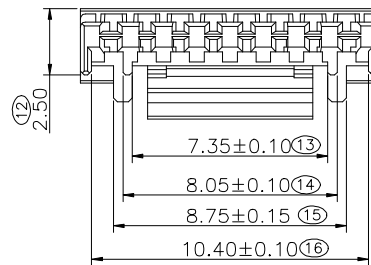
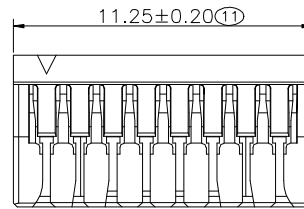
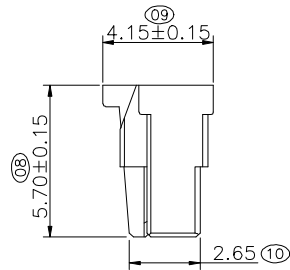
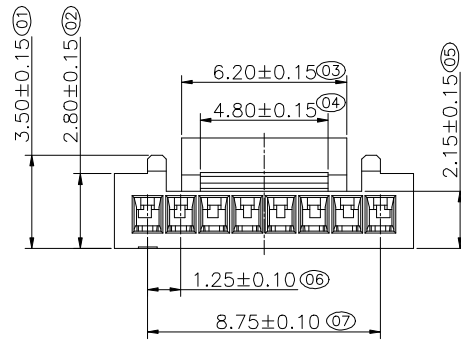

Specifications

Current Rating:AWG26:1.0Amp
:AWG28:1.0Amp
:AWG30:1.0Amp

Voltage Rating: 50V AC/DC.
Insulation Resistance:100MΩ Min.
Dielectric Withstanding Voltage:500V AC
Contact Resistance:30mΩ Max.
Operating Temperature:-25°C to +85°C
Materials
Regular Thermoplastic:Only Suitable for
Wave Soldering Process (PBT).
All materials must meet GREENCONN
hazardous substances control standards.

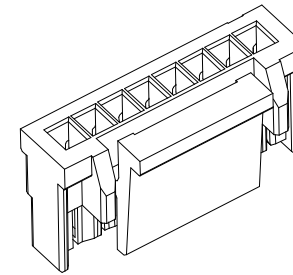

Ordering Information

G HD361 - XX A AJ - N
 No. of Pins per Row Standard Packing
 08 N=PE bag



Website:www.greenconn.com
E-mail:sales@greenconn.com

REV. A UNIT. mm SCALE. 4:1

3RD.ANG PROJ.

PAGE. 1/1

GENERAL TOLERANCE

X'±5.0'	X.±0.30
.X'±3.0'	.X±0.25
.XX'±2.0'	.XX±0.15
.XXX'±1.0'	.XXX±0.10

DESIGNED:

DATE:

CHECKED:

DATE:

APPROVED:

DATE:

DWG. NO.

GHD361-HA-N

PART NO.

GHD361-08AAJ-N

TITLE.

1.25mm PITCH
DISCONNECTABLE CRIMP STYLE
CONNECTORS-Housing

1 2 3 4 5 6 7 8 9

1 2 3 4 5 6 7 8 9

F
E
D
C
B
A

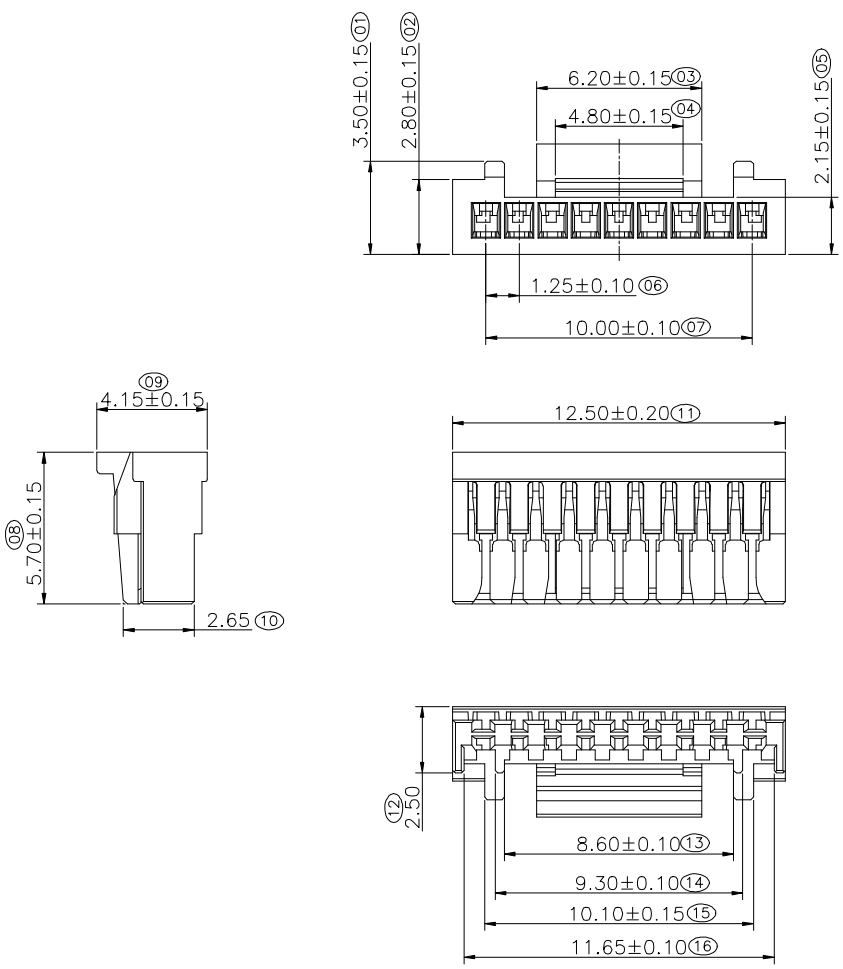

Specifications
 Current Rating:AWG26:1.0Amp
 :AWG28:1.0Amp
 :AWG30:1.0Amp
 Voltage Rating: 50V AC/DC.
 Insulation Resistance:100MΩ Min.
 Dielectric Withstanding Voltage:500V AC
 Contact Resistance:30mΩ Max.
 Operating Temperature:-25°C to +85°C
 Materials
 Regular Thermoplastic:Only Suitable for
 Wave Soldering Process (PBT).
 All materials must meet GREENCONN
 hazardous substances control standards.

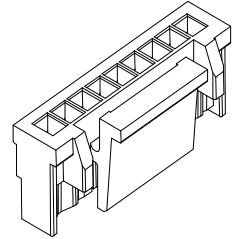

Ordering Information

G HD361 - XX A AJ - N
 No. of Pins per Row Standard Packing
 09 N=PE bag

 Website:www.greenconn.com E-mail:sales@greenconn.com	3RD.ANG PROJ.	GENERAL TOLERANCE		DESIGNED: CHECKED: APPROVED:	DATE: DATE: DATE:	DWG. NO.	TITLE. 1.25mm PITCH DISCONNECTABLE CRIMP STYLE CONNECTORS-Housing
	 PAGE. 1/1	X'±5.0'	X±0.30			DWG. NO.	
		.X'±3.0'	.X±0.25			PART NO.	
		.XX'±2.0'	.XX±0.15			GHD361-09AAJ-N	
REV. A	UNIT. mm	SCALE. 4:1	.XXX'±1.0'	.XXX±0.10			

1 2 3 4 5 6 7 8 9

1 2 3 4 5 6 7 8 9

F

E

D

C

B

A

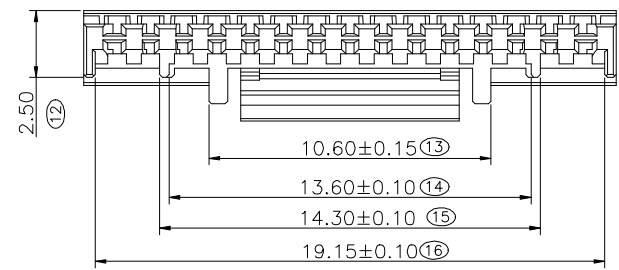
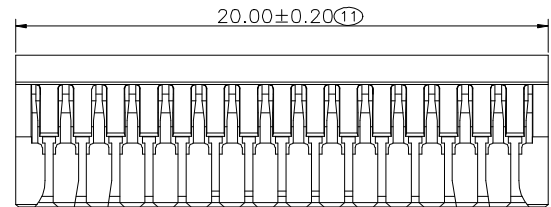
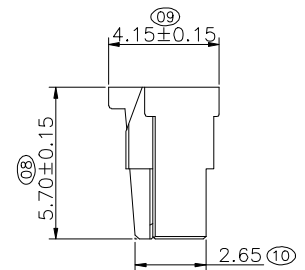
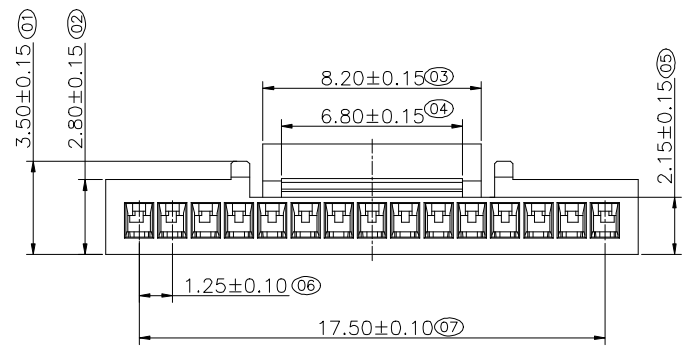

Specifications

Current Rating:AWG26:1.0Amp
:AWG28:1.0Amp
:AWG30:1.0Amp

Voltage Rating: 50V AC/DC.
Insulation Resistance:100MΩ Min.
Dielectric Withstanding Voltage:500V AC
Contact Resistance:30mΩ Max.
Operating Temperature:-25°C to +85°C
Materials
Regular Thermoplastic:Only Suitable for
Wave Soldering Process (PBT).
All materials must meet GREENCONN
hazardous substances control standards.

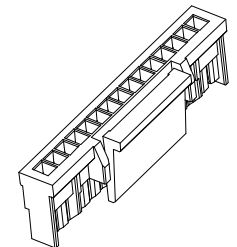

Ordering Information

G HD361 - XX A AU - N
 No. of Pins per Row Standard Packing
 09 N=PE bag

Greenconn
 Website:www.greenconn.com
 E-mail:sales@greenconn.com

REV. A	UNIT. mm	SCALE. 4:1
--------	----------	------------

3RD.ANG PROJ.

 PAGE. 1/1

GENERAL TOLERANCE	
X'±5.0'	X.±0.30
.X'±3.0'	.X±0.25
.XX'±2.0'	.XX±0.15
.XXX'±1.0'	.XXX±0.10

DESIGNED: DATE:
 CHECKED: DATE:
 APPROVED: DATE:

DWG. NO. GHD361-HA-N
 PART NO. GHD361-15AAJ-N

TITLE. 1.25mm PITCH DISCONNECTABLE CRIMP STYLE CONNECTORS-Housing

1 2 3 4 5 6 7 8 9