

www.szrunda.com

**RUNDA**  
www.szrunda.com

**RUNDA**

深圳市润达电子有限公司

地址：深圳市龙华新区民治街道龙润大厦1402  
电话：0755-29737378 29738118 13823642418  
传真：0755-29738128  
邮箱：szrunda@126.com  
http://www.szrunda.com

东莞市润达散热风扇有限公司

地址：东莞市塘厦镇平山村宝岭路371号  
电话：0769-82553188  
传真：0769-82553118  
移动电话：13823642418  
邮箱：runda@szrunda.com

东莞市润达散热风扇有限公司

DONGGUAN RUNDA COOLING FAN CO.,LTD

## 公司简介

润达于2003年在深圳龙华成立，因公司规模扩大，于2012年搬至东莞塘厦镇平山村宝岭路371号，建筑面积达8000余平方米，独门独院之标准厂房，可融纳千余名职员。

本公司主要生产直流、交流及交流转直流之轴流风机、鼓风机、离心风机、横流风机、风机护网等多种产品。主要应用于通信设备、家电、工控设备、汽车、高端PC、医疗设备等领域，产品销售面向欧洲、亚洲等国内外知名企业。

本公司拥有一支强有力的研发团队，是国家高新技术企业，拥有自己的高科技实验室及一流的仪器及生产设备，有自主品牌和知识产权。公司以客户需求及时代需要为导向来开发新的项目；我已经开发并验证OK的新产品有：大风压风量低噪音低功耗高性能风机系列和AC TO DC (EC) 节能风机，三相低噪音双向风扇等。

我司有通过ISO9001:2015、ISO14001:2015以及IAFT16949体系认证，产品有申请UL, TUV, CE, CCC等安规。

## Company Profile

RUNDA was established in 2,003 year in Shenzhen city. Because of expansion, we moved to Dongguan city in the end of 2012. Area is more than 8,000m<sup>2</sup>, independent standard workshop, can hold almost thousands employees.

We are majored in producing DC, AC, and AC to DC axial fans, blower, centrifugal fan, cross-flow fan, finger guard etc.. The main using is in communication equipment, home appliances, VMIC, car, High-end PC, Medical equipment. Product is sold out to many domestic and overseas well-known enterprises, such as Europe, Asia etc.

We have a strong team for researching and developing, and there is our own high-tech LABS and first-class equipments. Our guiding is customer demand and Times demand. Now there are some successful new products, high performance with large air-pressure and airflow but low noise and low power, energy-saving fan that AC TO DC (EC).

We through the management system ISO9001:2015 and environmental management system ISO14001:2015, IAFT16949 certification. Most of products are UL, TUV, CE, CCC compliant.

Our belief: Honest for foundation, Service best, Quality first, Technical Innovation.

Welcome all friends to come here and have a sincere cooperation for a better future!



厂区一角  
A Corner of Factory



风洞实验室 Windtunnellaboratory  
One: 0~100CFM, 0~100mmAq  
Two: 50~2000CFM, 0~250mmAq



噪音测试房  
背景噪音 < 14.1DB  
Acoustic Testing Laboratory  
Back Groud Noise < 14.1DB

## 产品应用/Application



# Table of Contents

目录/Contents.....	01	70mm*70mm*25mm	
EC风机简介/EC Fan Introduction .....	03	RS7025 Series.....	44
工程资料/Engineer Information.....	05	RS7025 A Series.....	45
命名方式/Method of Definition.....	16	75mm*75mm*20mm	
<b>DC Axial Fan Series 直流轴流风扇系列</b>		RS7520 Series.....	46
20mm*20mm*10mm		80mm*80mm*10mm	
RS2010 Series.....	17	RS8010 Series.....	47
25mm*25mm*10mm		80mm*80mm*15mm	
RS2510 Series.....	18	RS8015 Series.....	48
30mm*30mm*7mm		80mm*80mm*20mm	
RS3007 Series.....	19	RS8020 Series.....	49
30mm*30mm*10mm		RS8020 A Series.....	50
RS3010 Series.....	20	80mm*80mm*25mm	
RS3010 AJ Series .....	21	RS8025 Series.....	51
35mm*35mm*10mm		RD8025 Series.....	52
RS3510 Series.....	22	RD8025 A Series.....	53
40mm*40mm*10mm		80mm*80mm*32mm	
RS4010 Series.....	23	RD8032 Series.....	54
RS4010-B Series.....	24	80mm*80mm*38mm	
40mm*40mm*15mm		RD8038 Series.....	55
RS4015 Series.....	25	RD8038 Series.....	56
40mm*40mm*20mm		RD8038 AJ Series.....	57
RS4020 Series.....	26	80mm*80mm*56mm	
40mm*40mm*28mm		RD8056 Series.....	58
RD4028 Series .....	27	90mm*90mm*15mm	
RD4028-B Series.....	28	RS9015 Series.....	59
40mm*40mm*56mm		92mm*92mm*25mm	
RD4056 Series.....	29	RS9225 Series.....	60
50mm*50mm*10mm		RD9225 Series.....	61
RS5010 Series.....	30	92mm*92mm*28mm	
50mm*50mm*15mm		RD9228 Series.....	62
RS5015 Series.....	31	92mm*92mm*32mm	
50mm*50mm*20mm		RD9232 Series.....	63
RS5020 Series.....	32	92mm*92mm*38mm	
50mm*50mm*25mm		RD9238 Series.....	64
RS5025 Series.....	33	RD9238 AJ Series.....	65
60mm*60mm*10mm		120mm*120mm*25mm	
RS6010 Series.....	34	RS1225 Series.....	66
60mm*60mm*15mm		RD1225 Series.....	67
RS6015 Series.....	35	RD1225 C Series.....	69
60mm*60mm*20mm		120mm*120mm*32mm	
RS6020 Series.....	36	RS1232 Series.....	70
60mm*60mm*25mm		120mm*120*38mm	
RS6025 Series.....	37	RS1238 Series.....	71
RD6025 Series.....	38	120mm*120*38mm	
RD6025-B Series.....	39	RD1238 Series.....	72
60mm*60mm*38mm		RD1238 Series.....	73
RD6038 Series.....	40	RD1238 C Series.....	74
RD6038 A Series .....	41	130mm*130mm*38mm	
70mm*70mm*10mm		RD1338 Series.....	75
RS7010 Series.....	42	140mm*140mm*25mm	
70mm*70mm*15mm		RS1425 Series.....	76
RS7015 Series.....	43		

# Table of Contents

140mm*140mm*38mm		60*60*38mm	
RD1438 Series.....	77	RT6038 Series.....	105
140mm*140mm*50mm		80*80*25mm	
RD14050 Series.....	78	RT8025 Series.....	106
150mm*150mm*51mm		80*80*32mm	
RS1551 Series.....	79	RT8032 Series.....	107
160mm*160mm*50mm		80*80*38mm	
RS16050 Series.....	80	RT8038 Series.....	108
172mm*150mm*25mm		92*92*25mm	
RS1725 Series.....	81	RT9225 Series.....	109
172mm*150mm*51mm		92*92*32mm	
RS1751 Series.....	82	RT9232 Series.....	110
RD1751 Series.....	83	92*92*38mm	
RS1751 C Series.....	84	RT9238 Series.....	111
180mm*180mm*60mm		120*120*25mm	
RD18060 Series.....	85	RT12025 Series .....	112
200mm*200mm*60mm		120*120*38mm	
RS20060 Series.....	86	RT1238 Series .....	113
200mm*200mm*53mm		160*160*50mm	
RS20053 Series.....	87	RT16050 Series .....	114
200mm*200mm*70mm		172*150*51mm	
RS20070 Series.....	88	RT17251 Series .....	115
220mm*30mm		200*200*70mm	
RS2230 Series.....	89	RT20070 Series .....	116
524mm*89mm		254*89mm	
RD25489 Series.....	90	RT25489 Series .....	117
<b>DC Blower Series 直流鼓风机系列</b>		<b>Standard AC Axial Fan Series 标准交流轴流风机系列</b>	
25*12mm		80*80*25mm	
RB2512 Series.....	91	AC8025 Series .....	118
30*4mm		80*80*38mm	
RB3004 Series.....	92	AC8038 Series .....	119
35*17mm		92*92*25mm	
RB3517 Series.....	93	AC9225 Series .....	120
40*10mm		110*110*25mm	
RB4010 Series.....	94	AC11025 Series .....	121
40*20mm		120*120*25mm	
RB4020 Series.....	95	AC12025 Series .....	122
50*15mm		120*120*38mm	
RB5015 Series.....	96	AC12038 Series .....	123
50*20mm		150*150*51mm	
RB5020 Series.....	98	AC15051 Series .....	124
60*25mm		172*150*51mm	
RB6025 Series.....	99	AC17251 Series .....	125
75*25mm		180*180*60mm	
RB7525 Series.....	100	AC18060 Series .....	126
75*30mm		200*200*60mm	
RB7530 Series.....	101	AC20060 Series .....	127
97*33mm		254*89mm	
RB9733 Series.....	102	AC25489 Series .....	128
120*32mm		<b>Metal Finger Guard Series 金属护网系列</b>	
RB1232 Series.....	103	RM-XX Series.....	129
<b>EC Fan series EC 风扇</b>		<b>PLastic Filter Guard Series 塑胶滤网系列</b>	
60*60*25mm		RP-XX Series.....	130
RT6025 Series.....	104		

## EC(AC TO DC) Brushless Fan

AC风扇（即交流）与DC风扇（即直流）区别于下：

品名	转速最高值	耗省电力	效率	噪音	调速能否	寿命
AC风机	受限，最高转3000左右	功耗大	低	高	几乎不能	短（温升高）
DC风机	可达数万转每分钟	功耗低	高	低	从几百转到几万转可调	长（温升低）

从以上方面作对比，DC风扇有着明显的优异之处，但是DC风扇要工作也得需要外加电源，往往在以下方面受到限制。需要电源，就得面临以下几个方面的问题：

比如一只风扇正常工作时需要50W的功率，就得配75以上的电源，因为得考虑用量，这样一来得面临以下问题。

- 成本升高（电源+风机）
- 空间小的地方无法放置电源，特别有的地方需要几只风机，电源相应也得成倍增加，体积也就相应增大，空间成问题。
- 一般电源效率在85%左右，有15%的电能在损耗
- 电源与风机的匹配还得考虑EMC问题，以上方面是DC风扇不完美的一面。

本公司有着高科技的技术研发人员和较完美的实验室，现成功地开发出高效EC风机，帮您解决这些问题。

本公司开发的EC即AC TO DC风机有以下几方面的优点：

- 体积小，同DC或AC普通风机，不需电源。
- 采用高压三相或全波桥驱动，超高效率，是普通AC的3倍以上。
- 可作温控及PWM功能，节能降噪。
- 可作风机故障报警功能。
- 可输出转速信号，方便系统的风机管理。
- 电流功率仅AC的三分之一以下，发热量小，温升低，寿命长。
- 电压范围宽，从几十伏到230V以上。
- 可作AC 110V与AC220V共用，转速相同。
- 风机可带恒速功能，转速不受外界电网电压的波动而波动。
- 成本低于电源+DC风机的价格。
- 自带EMC滤波，干扰小。
- 带软启动（即缓慢启动），杜绝冲电流带来的器件损伤。
- 无交流声。

## EC(AC TO DC) Brushless Fan

Differences between AC Fan and DC Fan are showed below :

Item	Max. Speed	Consumes Power	Efficiency	Noise	Control of Speed	Life
AC fan	Limited,Max.3000rpm	High	Low	High	Almost impossible	Short and high Temperature rise
DC fan	Almost tens of thousands rpm/min	Low	High	Low	Adjust in range 500~20000rpm	Long and low Temperature rise

Compared as above, DC fans have very obvious advantages, but they need extra power supply to drive them. So DC fans may meet some problems from power supply as below:

For example, a dc fan need 50W power during normal working, and we must give it power more than 75W. Now there some problems:

- High cost: power supply and fans
  - Space: You need enough space to place power supply, especially when you fix a few pieces of fan, more power supplies need at the same time. Then the space will be a problem.
  - Waste of energy: General power efficiency is at least 85%, and 15% is waste at least.
  - You'd consider the EMC matching between power supply and fans
- These points are the side of defectives on DC fans.

**Our company has a high-tech team and perfect laboratory for technology researching and developing. Now we have developed efficient EC fan to help you solve these problems.**

**Our EC fans have so many advantages:**

- Small volume, don't need extra power supply;
- High volt three-phase or whole wave bridge driver, super efficiency, more than 3 times than normal AC fans;
- Temperature control and PWM control available, energy saving and noise reduction;
- Fault Alarm Function available;
- FG signal output. It is convenient for system to manage fans;
- Low power dissipation(1/3 of AC fans), low temperature rise, long life;
- Wide range of operation voltage, AC 30V~AC 230V;
- Constant Speed Function, speed remains at the same when the volt is changed;
- The cost is lower than the sum of power supply and DC fan;
- Soft Start Function is available so it can avoid electronic components damaged by impulse current;
- Filter inside, little interference;
- None noise like AC fans;
- It has two voltages. No matter you input AC110V or AC220V, the speed is the same.

# Engineering Information

## 专业术语名词列表及解释 Professional terms list and interpretation

保护方式/Protection Function		
专业名词 Specialized Word	解释 Definition	参考文献 Reference
RP	Reverse Protection的缩写, 正负极反接保护(自带极性保护二极管), 防止正负极接反而烧毁风机	
AS	Auto Re_Start的缩写, 转子锁定保护, 自动重启功能	F1
SS	Soft Start的缩写, 软启动, 电流及转速缓慢上升	F2
CL	Current Limit的缩写, 限流保护	

信号输出方式/Signal Output		
专业名词 Specialized Word	解释 Definition	参考文献 Reference
FG	Frequency Generator的缩写, 频率发生器, 用来侦测风扇转速	F3
RDH(RD)	Rotation Detection的缩写, 运转状态侦测, 停转高电平报警	F4
RDL(RDb)	Rotation Detection的缩写, 运转状态侦测, 停转低电平报警	F4
LD	Low Detection的缩写, 转速低于极限值输出高电平报警	F5

调速方式/Speed Control		
专业名词 Specialized Word	解释 Definition	参考文献 Reference
PWM	Pulse wide modulation的缩写, 固定频率, 占空比调速	F6
TC	Temperature Control的缩写, 温度控制转速	F7
VC	Voltage Control的缩写, 电压信号控制转速	F8
RC	Resistor Control的缩写, 电阻(通常情况下用电位器)控制转速	F9
CS	Const Speed的缩写, 达到额定电压后恒定转速	F10

- 导线颜色定义: Colors of lead wires:
- 电源正极: 红色 Positive: Red
  - 电源负极: 黑色 Negative: Black
  - 方波FG信号: 黄色 FG signal: Yellow
  - 报警RD信号: 灰色 RD signal: Gray
  - 报警RDb信号: 白色 RDb signal: White
  - 报警LD信号: 褐色 LD signal: Brown
  - PWM信号: 蓝色 PWM control: Blue
  - 电压调速VC信号: 绿色 VC control: Green
  - 电阻调速RC信号: 紫色 RC control: Purple
  - 正反转控制CW/CCW信号: 黄绿斑马条色 CW/CCW control: Yellowgreen Zebra Stripes

信号输出标准接口电路/Signal output standard interface circuit diagram

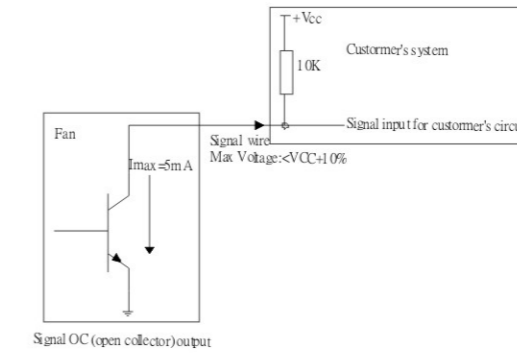

PWM输入标准接口电路/PWM input standard circuit diagram

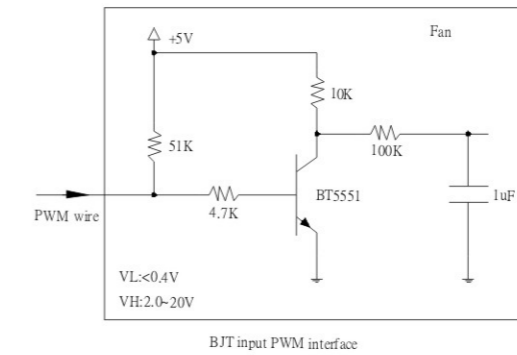

VC(电压讯号调速)输入标准接口电路/VC input standard diagram

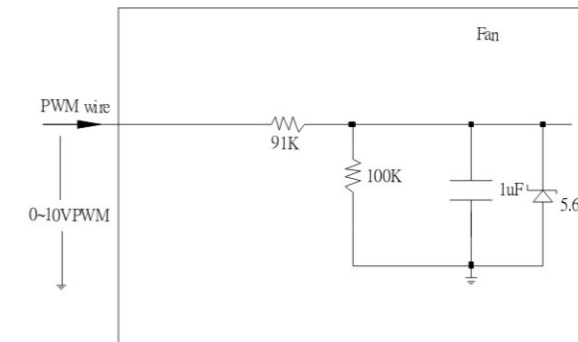

RC(可调电阻)输入标准接口电路/RC input standard diagram

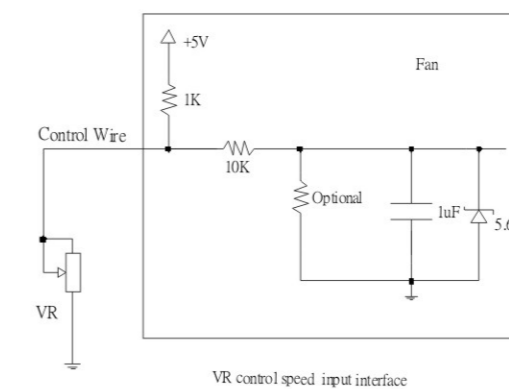

## F1:AS(Auto Restart)自动重起功能：

当转子受外力作用被堵转，风扇内部自动断电（即电流降到很低），进行保护。每隔3~5秒钟后自动重新判断是否继续受阻，直到外力解除后重新启动运转。

AS: Auto Restart Function

The motor can auto-power off when rotor is locked at rated voltage for 1sec to protect itself. Then the circuit attempts to restart in 3 to 5 sec until the force released.

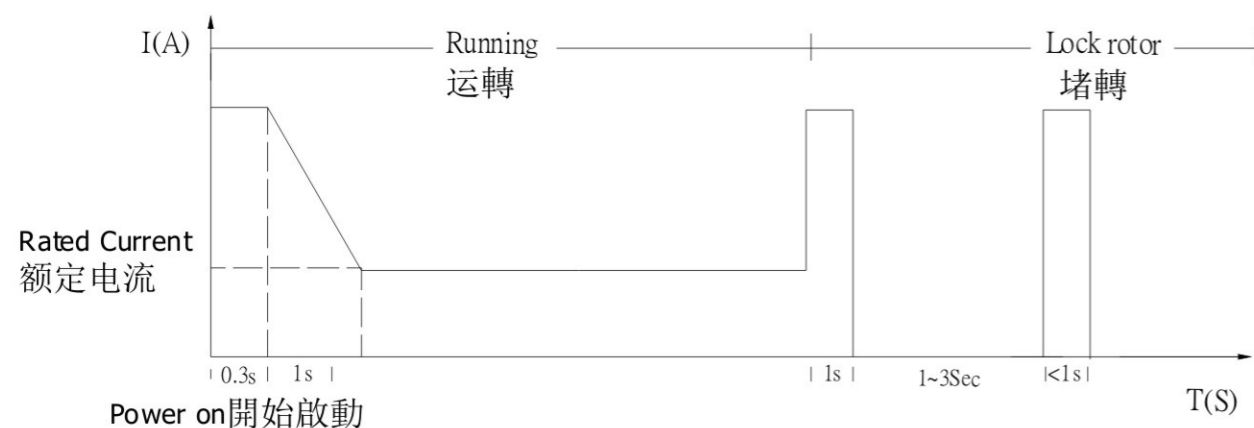

Without SS function 不带SS功能

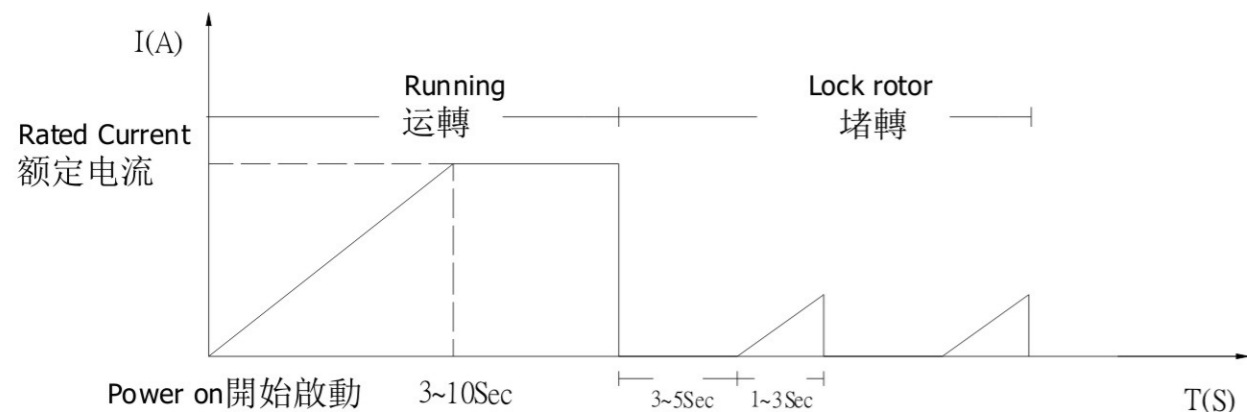

With SS function 带SS功能

## F2 : SS功能:

名词解释：Soft Start 软启动，又称缓启动或防冲击电流保护IR功能（Inrush current protection）。

Definition: Soft Start (also called Inrush Current Protection).

软启动功能是指风机上电,转速从零缓慢上升到额定转速,大约需要3-10秒;电流因此也是从零开始缓慢上升到额定的电流范围。

SS means fan electricity, rotate speed from zero to the rated speed will cost 3-10 seconds; also current is up to the rated range from zero slowly.

软启动对于大风机的作用在于:由于风机内部定子由线圈与电子驱动构成,线圈乃属感性负载。在刚通电时扇叶由静止到全速运转,流过线圈的电流特别大(刚启动瞬间线圈感抗就等于线圈纯直流电阻),此时的冲击电流在额定电流的3-5倍以上,(如额定电流在1A左右,冲击电流会在3-5A以上)。这样一来,对客户的电源冲击能力就要求过高,例如选用额定电流为48V,1A的风机,电源功率得 $48V \times 5A = 240W$ 以上。带软启动的风扇,电流不会冲击到如此之高,最高电流就等于额定电流的+10%左右;例如:48V 1A的风扇,只需要50W以上即可(当然依具体情况留一定的余量)。50W的电源与240W的电源相比,成本及占用空间有明显差距,从这个角度上,使用带软启动的风扇在整体成本上有所优势,且节能。另外,带软启动的风扇冲击电流小,对风扇内部器件危害小,性能更安全。

SS role in the big fans is: because the stator is consist of the coil and electronic drives, and the coils belong to perceptual load .At the beginning of fan electricity, there is a great of current through the coils when the blades from static to full speed. (At the start moment the inductive reactance is as much as the pure dc resistance). At this time the impulse current is 3-5 times to the rated current (E.G current is 1A, the impulse current will be 3-5A) so it is a high requirement to the customers' power impulse ability. For example, the fan with rated current 48V, 1A, the power consumption will up to  $48V \times 5A = 240W$ . The fans with SS, only need 50W (According to the specific situation it will keep some margins). Compare 50W power with 240W power, there's an obvious difference between the costs and spaces. In this situation, it offers advantages to use the fans which with SS function, and efficient. Other way, the fans with SS function have small impulse current, on the inside devices little harm and safer.

本公司有资深的软硬件工程师,设计出来的大风机均具有良好的软启动功能。

Our company has senior hardware and software engineers.The big fans designed out are with well SS function.

不带SS功能与带SS功能的上电及堵转示意图如下所示：

With and without SS function's power up and plugging turn work schemes as the chart:

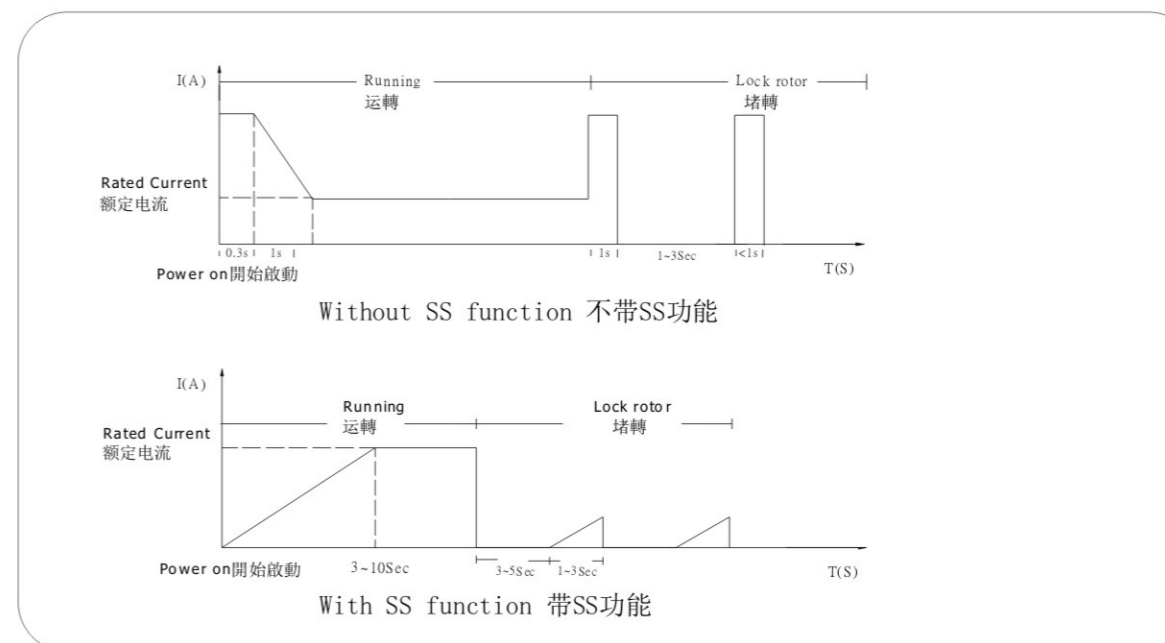

### F3:FG(Frequency Generator)频率发生器：

风扇运转时，转子的N, S极切换会产生高低电平变化，转速越快，电平变化也就越快。从而可以通过变化的频率来侦测风扇的转速。  
 每分钟的转速=方波频率\*(120/磁极个数)

#### FG(Frequency Generator)

When fan is running, the switch of rotor N, S can make exchange of high and low level. And speed faster, the frequency of level exchange faster. So we can sense fan's rotation speed via the signal of variational frequency.  
 $Rpm/min = \text{frequency of square wave} * (120/\text{poles})$

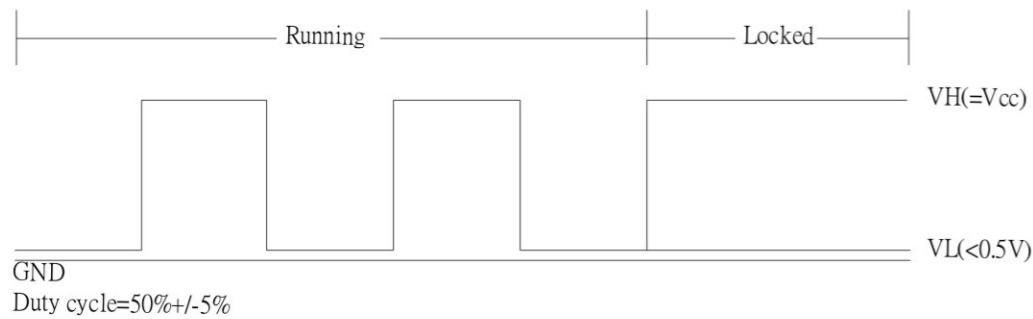

### F4:RD(Rotation Detection)运转状态监测，堵转报警：

RD ( RDH ) 运转时候信号引脚输出低电平，转子堵住时输出高电平；RDb ( RDL ) 与此相反。外部设备通过检测高低电平的判断来分辨该风可是处于运转状态还是非运转状态。

#### F4: RD(Rotation Detection)

RD(RDH):When running, output low level;when locked, output high level;  
 RDb(RDL):Just contrast. When running, output high level;when locked, output low level;  
 External equipment will distinguish the fan is working or not through the inspection of high and low level.

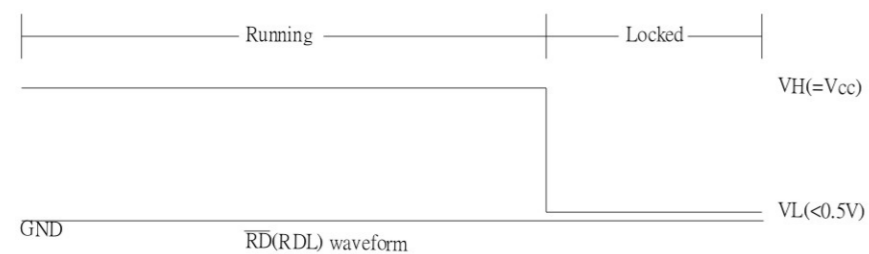
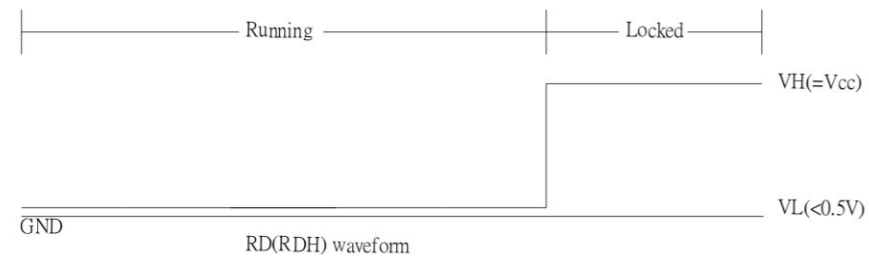

### F5 : LD功能:

名词解释：Low Detect,转速低于设定值报警。

Definition: Low Detect, Output alerting signal when the rotate speed is below the setting.

LD的功能是指:风扇转速低于设定的极限转速时输出高电平报警信号,如某规格的风扇转速标准为5000RPM ; 可设定70%以下转速时 ( 即低于3500RPM) 开始报警。(该极限转速值可由客户决定，一般默认为低于70%额定的转速开始报警)。

It means that the fan will output the high level alerting signal when the rotational speed lower than the limit speed which was setted before. For example, one kind of fan's normal speed is 5000rpm, we can set it to start alerting when its speed is lower than 70% of it(below 3500 RPM).(The limit speed could be charged by customers, generally the default is that it starts alerting when the speed is lower than 70% of its rated speed).

该功能与RD报警信号的不同在于:RD功能只要风扇在运转，不论转速多少,只要不停转就不报警,而LD功能是转速低于设定值时就开始报警。

The difference between LD and RD is:For RD ones, as long as the fan is working, no matter what the speed is, it starts warning only when the fan is out of working. But LD starts warning when the speed is lower than the given speed.

风扇使用时间长了,轴承组合之间，或定子与转子间难免会有灰尘,这样一来可能会导致风扇转速的降低,当然元器件的不良也可能导致转速降低。这样一来,如果是使用的RD功能则不会报警提示,但是使用LD功能,则会报警提示更换该风机,以免风机转速过低无法散热造成设备温升过高,而工作不正常。

Long time using the fans, it is hard to avoid dust between the bearing unit assembling, the stators and rotors. It will lead to the fan's speed reduced, certainly the problem of components also may lead to the results. In this situation, if use the RD it will not be warned ,but in use of LD, it will warn to change the fan in order to avoid the equipments' temperature too high by the fan's lower speed that make the unusual working.

RD与LD功能的工作示意图如下图所示：

The RD and LD's work schemes as the chart:

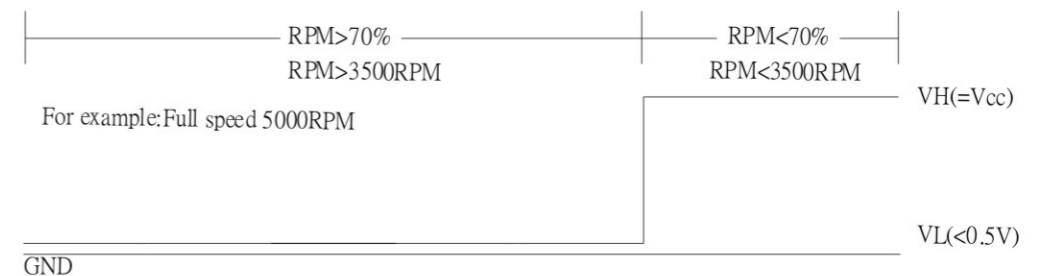
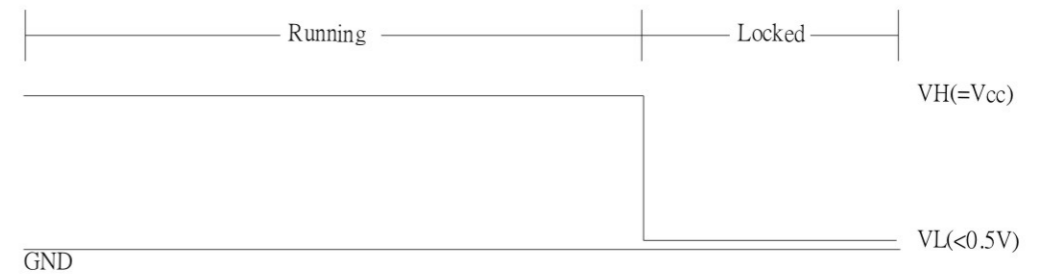

## F6 : PWM调速功能

PWM控制调速(Pulse Width Modulation)脉冲宽度调速,频率可从20HZ-30KHZ。高电平电压范围可以从2.5V-20V,低电平范围 $\leq 0.5V$ 。该调速是通过固定频率的变脉,调整其宽度(也就是占空比Duty cycle)来改变风扇转速。6种常见曲线模式如下图所示,当然还可依客户制定,占空比VS转速的关系。

PWM control, Pulse Width Modulation. Frequency can be from 20HZ~30KHZ. High-level voltage is from 2.5V~20V, and low-level $\leq 0.5V$ . This control via variational pulse of fixed frequency to adjust its width(Duty cycle) and then alters speed. Of course, we can work out the relation of duty cycle and Voltage according to

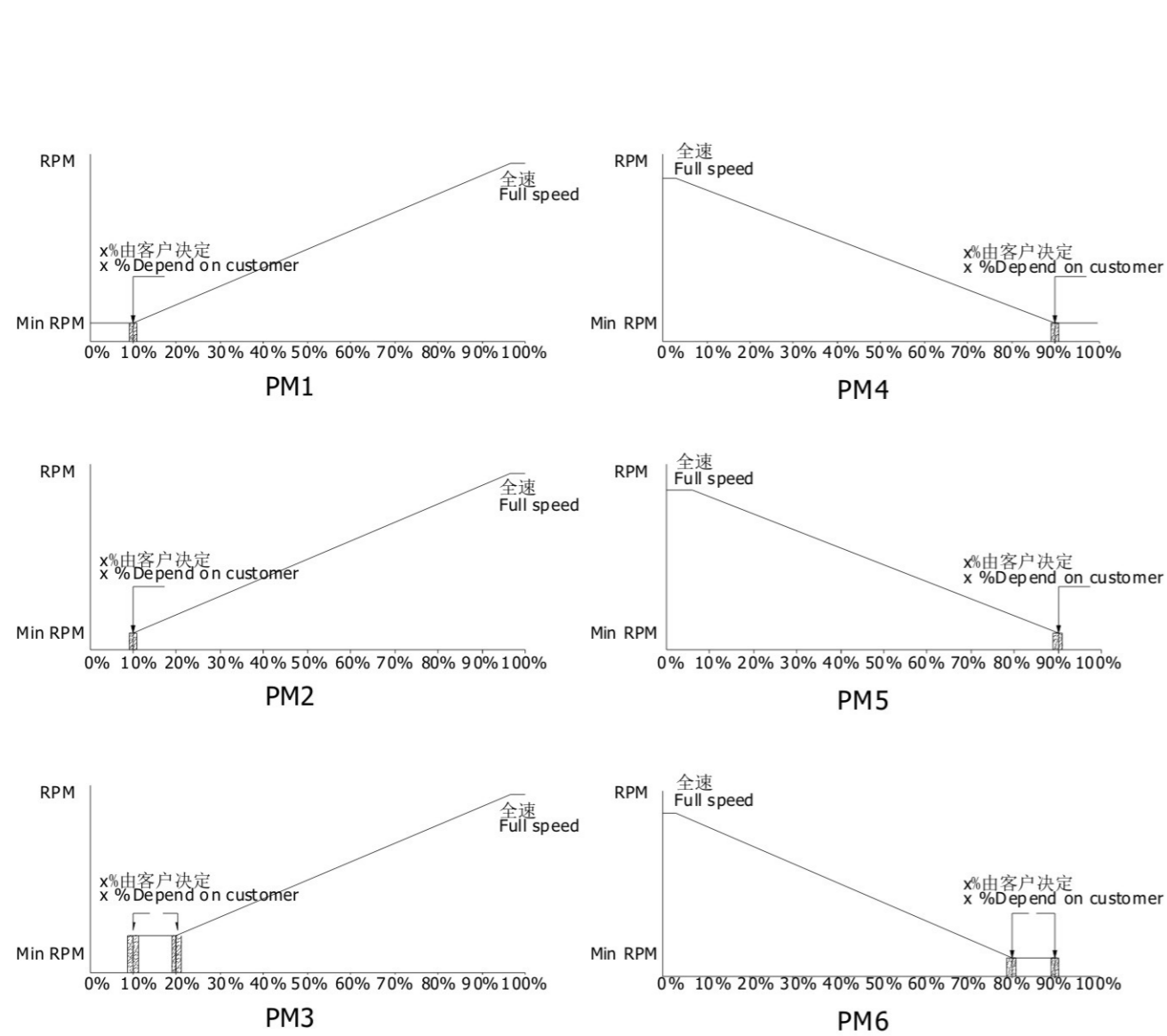

## F7 : TC调速功能

TC控制调速(Temperature Control)温控功能风机,风扇的转速受温度控制.不同的温度可对应不同的转速(温度Sensor可在风机内挂或通过引出线的方式外挂)。常见的3种曲线如下图所示:

TC(Temperature Control) : Speed is controled by temperature. Different temperature corresponds different speed(Temperature sensor can be filled inside or connected outside as lead wires). There are three normal curves showed below:

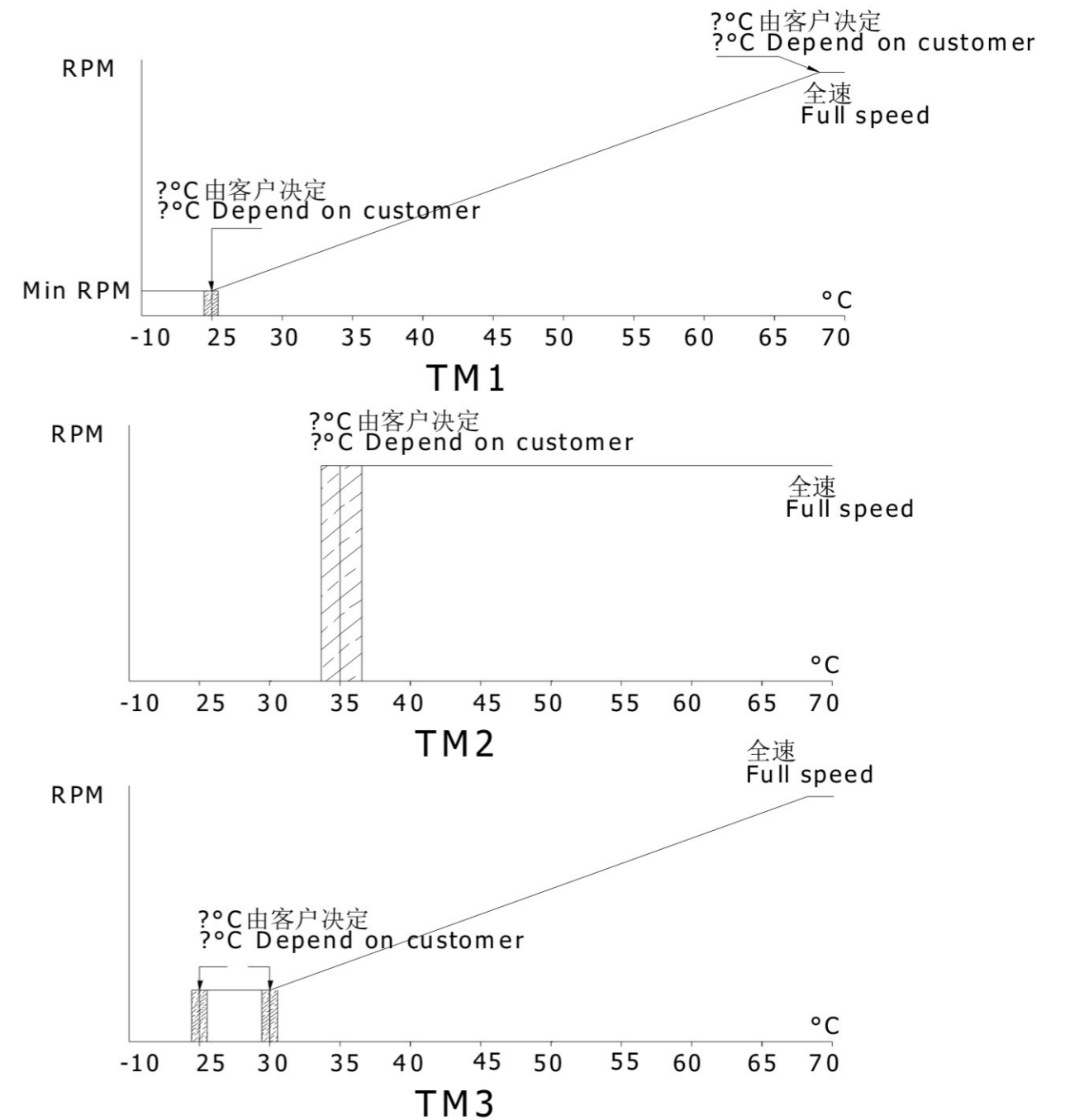

## F8 : VC模拟电压信号调速(Voltage Signal Control)

转速依电压信号高低来控制风扇之转速,不同的输入电压可对应不同的转速.电压信号一般可设定范围为0-20V之间,一般推荐使用0-5V,控制信号电压消耗电流 $\leq 1\text{mA}$ ,常见的6种曲线如下图所示:

Third: VC mode(Voltage Signal Control)

Speed is controlled by voltage signal.Different input volt and different speed.Usually the range of volt signal is at 0~20V, but we suggest 0~5V.And the voltage of signal control uses up current $\leq 1\text{mA}$ .There are six common curves below:

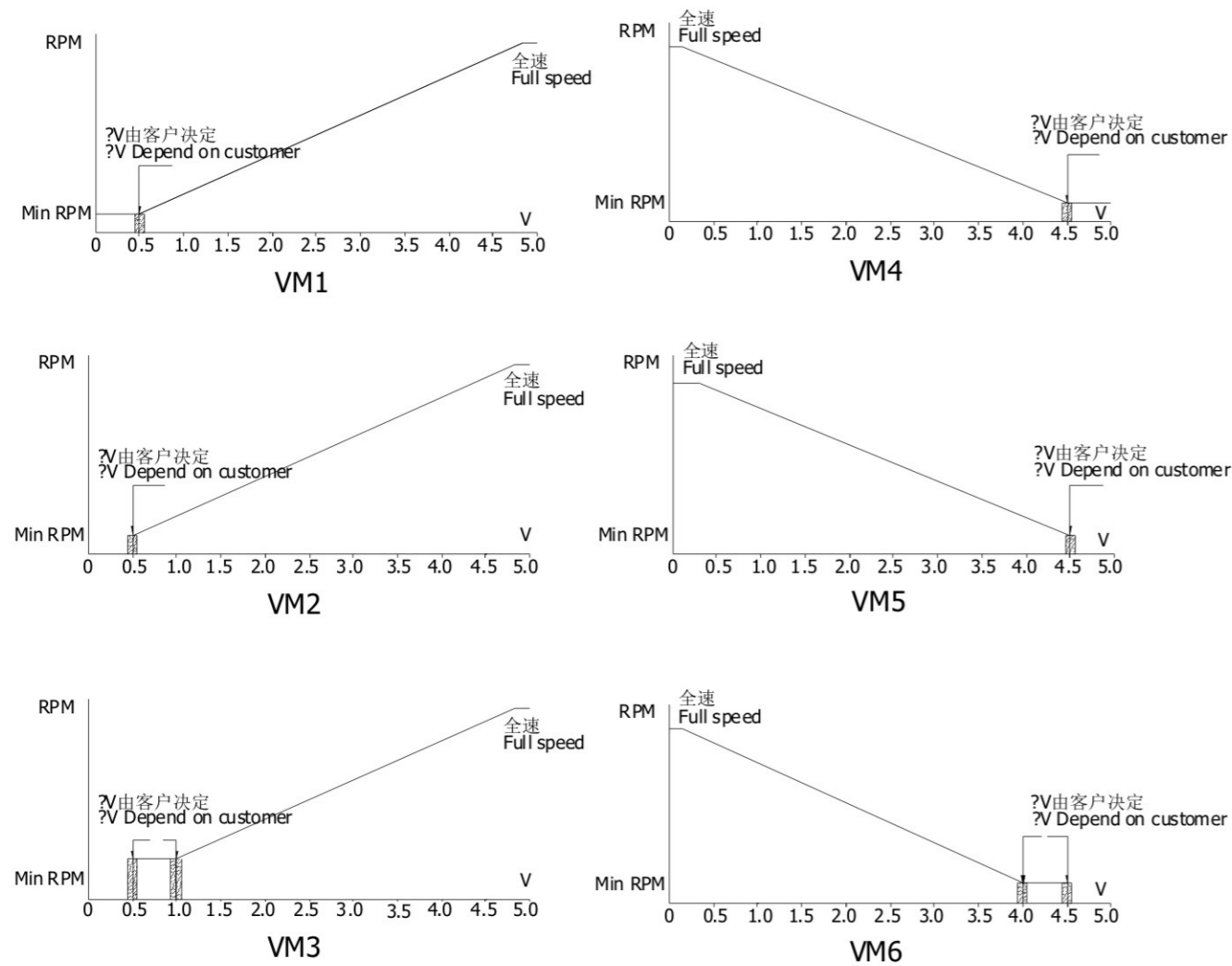

## F9 : RC电阻调速(Resister Control)

通过改变风机外挂电阻的阻值(一般用可调电阻)来改变风机转速,即不同的电阻值对应不同的转速。(一般建议用10K可调电阻)常见的3种调速方式如下图所示:

RC(Resister Control)

When we adjust the resistivity of resistance(usually use adjustable resistor), the speed will be changed.That means different resistivity and different speed.And we suggest to use 10K adjustable resistor.There are three common ways to regulate speed:

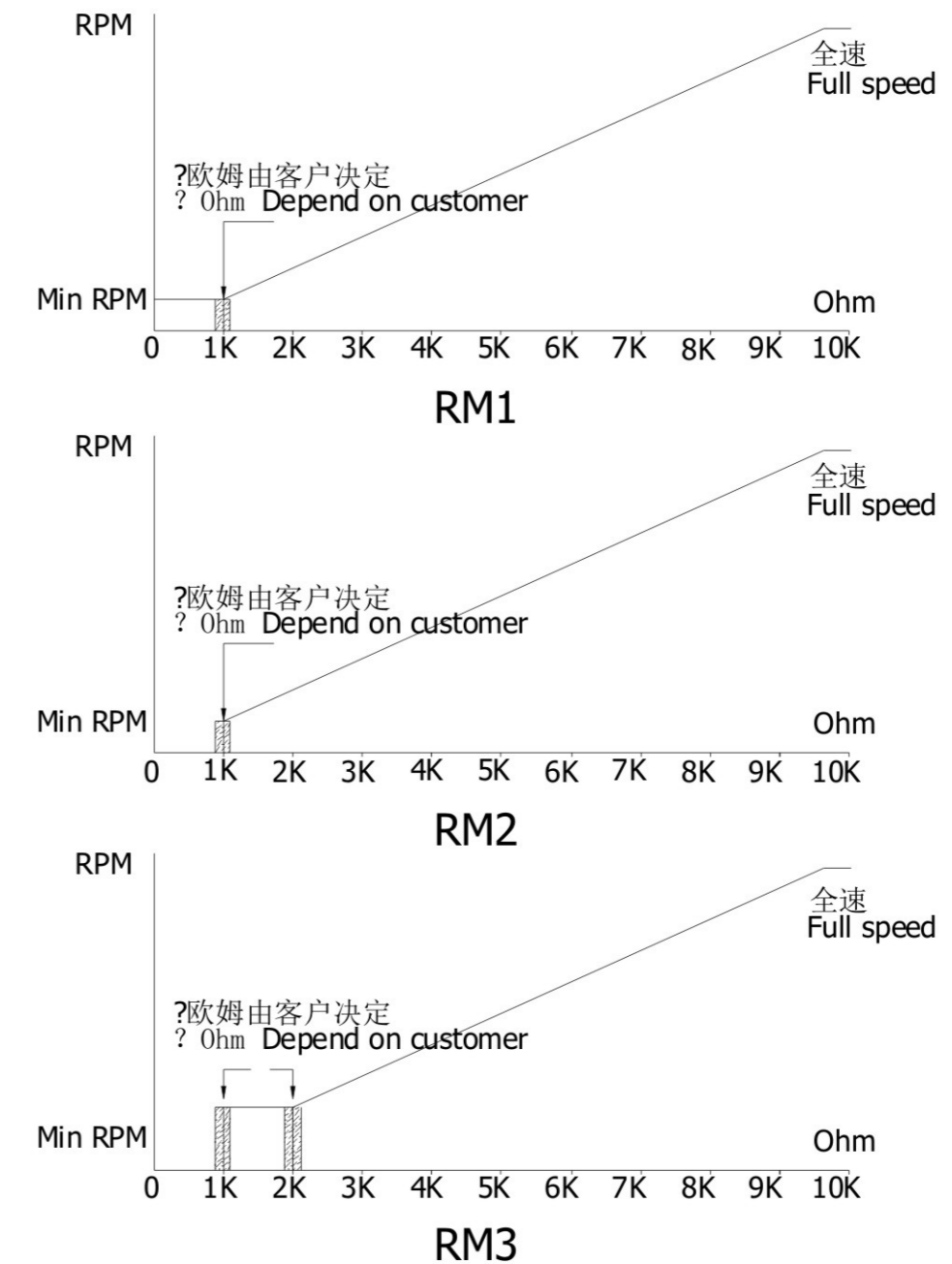

## F10 : CS功能(CS Function) :

名词解释：Constant Speed 恒定的转速，即恒速功能。

Definition: Constant Speed.

恒速是指风机在额定电压至该风机的最高承受的电压范围内，转速保持恒定不变。(如48V风扇，上限电压为72V,那么只要供电电压在48V-72V之间时，风扇保持额定转速不变。

It means that the speed remains the same at range between rated voltage to the highest voltage it can undertake. For example, a 48V fan, its limit voltage is 72V, so when supply voltage changes between 48V~72V, speed would remain at rated.

普通的风扇（不带恒速功能的），转速随电压的升高而升高，同时电流也随之升高，同样噪音也随之升高。当电压有波动时，转速就不稳定，电流及噪音忽高忽低。在一些宽电压范围的应用上，普通风扇不太适用，如12038风扇，48V/1A/5000RPM的风扇，在上限电压72V时，转速约为8000RPM以上，电流在2.2A以上，噪音在65DB以上。这样一来，转速上升，功率增大，电流升高，风扇内部温升过高，寿命也就相应下降，长期以来，器件也容易损坏。这样不利于节能，低噪音及长寿命的重要性能指标。

But for normal fans, voltage higher and speed higher, at the same time, current higher, noise level higher. If voltage isn't steady, speed, current, and noise level are high and low. So normal fans are not suitable for wide voltage range using. 120x120x38mm fan, 48V/1A/5000RPM, when it reaches limit voltage 72V, speed will reach 7000rpm, and current is 2.2A at least, noise not lower than 65DB. Then the power is too high, and inner temperature too high also, the life expectancy will be shorter. For a long time, components are easy to break. It affects fan's reliability.

带恒速功能的风扇，因在允许的电压范围内转速不变，噪音也就不变，功率不变，有利于实现节能，低噪音，长寿命的时代需求。

If fan with CS function, in allowed voltage range, the speed, noise, power are all remain the same. It meets inevitable demand of the times, energy conservation, low noise, long life.

一般通讯设备，电压范围从36V-72V间切换，提倡使用CS功能风扇。

For normal communication apparatus, its voltage switch between 36V~72V, so we suggest customer to use fan with CS function in it.

不带CS功能的风扇与带CS功能的风扇其转速，功率，电流，噪音，温升，寿命对应其电压的关系曲线如下图所示：

Pls see the below curve showed differences between normal fans and CS fans on speed, power, current, noise, inner temperature, life expectancy etc.:

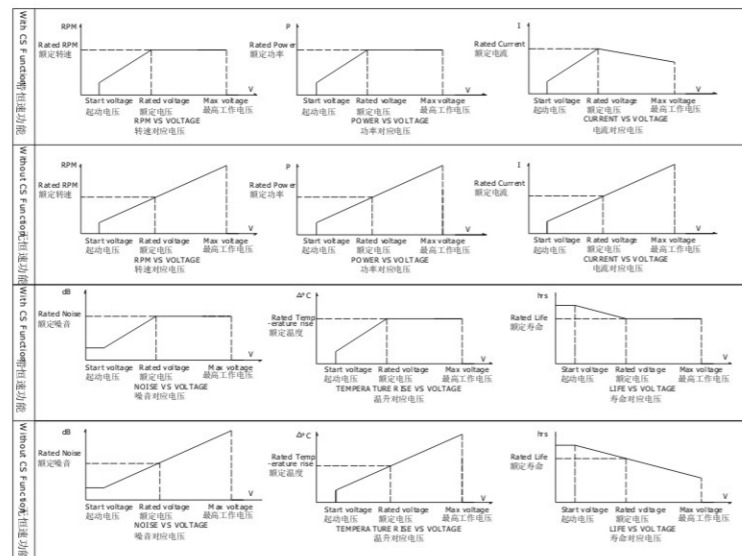

## 命名规则

### PART NUMBER CODE 规格代码定义

Example 举例：RD1225B48L-RPS

R	D	12	25	B	48	L	-	R	P	S
RUNDA 润达高性能风机		Product NO. 产品种类		Frame size: 外框尺寸		Frame thickness: 外框厚度		Bearing system: 轴承结构		
S: standard 普通 D: H_Air 高风压/量		80: 80*80mm 92: 92*92mm		B: 2Ball 双滚珠 L: Long life sleeve 长寿命含油		25: 25mm 38: 38mm		S: Sleeve 含油轴承 FDB 动压轴承		
T: Third 第三代产品 B: Blower 鼓风机		12: 120*120mm		Rated voltage 额定电压		51: 51mm*****		05: 5V 12: 12V 24: 24V 48: 48V 11: 110V 22: 220V		
C: Centrifugal/Crossflow fan 离心/横流风机		17: 172*172mm*****		Speed 转速		Speed control model 转速控制方式		Protection model 电路保护方式		
				D=Ultra low Speed 超低转速 L=Low Speed 低转速		P: PWM V: VC T: TC R: RC		S: SS A: AS		
				M=Medium Speed 中转速 H=High Speed 高转速						
				VH=Extra High Speed 超高转速						
				SH=Ultra High speed 超高转速						
				UH=Extra ultra high speed 极限转速						
				Signal output 信号输出方式						
				F: FG R: RD B: BDb L: LD						

# DC AXIAL FAN

## 20x20x10mm

### RS2010 Series



外框材质:环保防火PBT  
Frame:Thermoplastic PBT UL94-V0  
扇叶材质:环保防火PBT  
Imperller:Thermoplastic PBT UL94-V0  
轴承结构:双滚珠或长寿命含油结构  
Bearing system:2Ball or Long life sleeve  
单体风扇重量:6g  
Unit Weight:6g

DIMENSIONS DRAWING

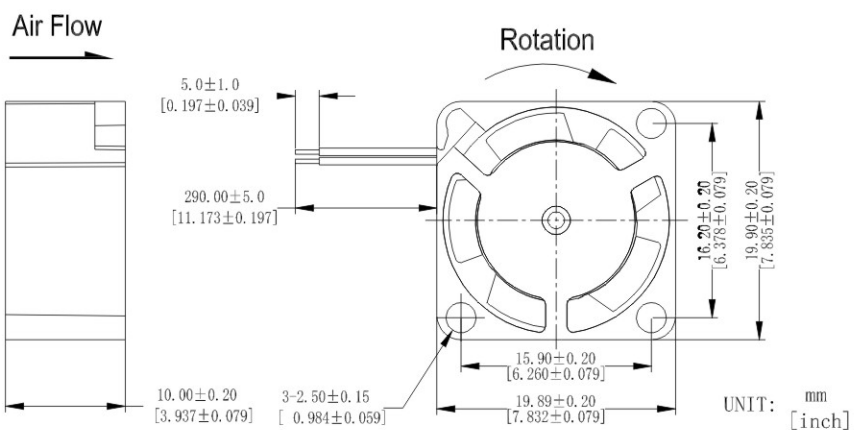

Fan Performance Curve

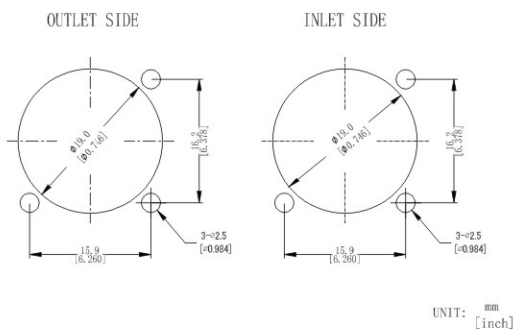
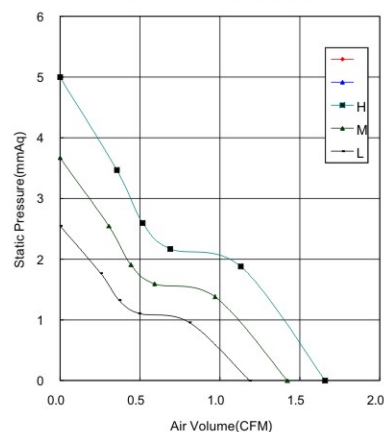

#### 可选的功能参照列表 (Available Functions)

##### 1. 马达保护 (Motor protection)

RP	SS	AS	CL
<input type="checkbox"/>	<input type="checkbox"/>	<input type="checkbox"/>	<input type="checkbox"/>

##### 2. 信号输出 (Signal output)

FG	RD	RD	LD
<input type="checkbox"/>	<input type="checkbox"/>	<input type="checkbox"/>	<input type="checkbox"/>

##### 3. 调速方式 (Speed control mode)

PWM	TP	VC	RC	CS
<input type="checkbox"/>	<input type="checkbox"/>	<input type="checkbox"/>	<input type="checkbox"/>	<input type="checkbox"/>

Part Number	Voltage (V)	Current (A)	Power (W)	Speed (RPM)	Air flow (Q)	Pressure (P)	Noise (dBA)		
产品编号	电压范围	额定电流	功率	转速	(CFM)风量	m <sup>3</sup> /min (mmAq)风压	(In H <sub>2</sub> O) 噪音		
RS2010x05L	5 (4~6)	0.07	0.35	10000	1.18	0.03	2.55	0.10	21.6
RS2010x05M		0.09	0.45	12000	1.42	0.04	3.67	0.14	23.0
RS2010x05H		0.16	0.80	14000	1.66	0.05	5.00	0.20	23.2

★ 如果您需要的转速或电压或功能不在这份清单上, 请与我们联系。  
If you want another rpm or voltage or functions which one is not in the list, please contact with our sales.

★ 提示1:功能的具体信息参照产品目录前页篇章。  
Notes1:The catalog have detail information in the front page for the functions.

★ 提示2:产品详细信息请参照承认书。  
Notes2:Product have a detail in the approval sheet.

★ 提示3:产品规格变更不另行通知。  
Notes3:Specifications are subject to change without notice.

# DC AXIAL FAN

## 25x25x10mm

### RS2510 Series



外框材质:环保防火PBT  
Frame:Thermoplastic PBT UL94-V0  
扇叶材质:环保防火PBT  
Imperller:Thermoplastic PBT UL94-V0  
轴承结构:双滚珠或长寿命含油结构  
Bearing system:2Ball or Long life sleeve  
单体风扇重量:7g  
Unit Weight:7g

DIMENSIONS DRAWING

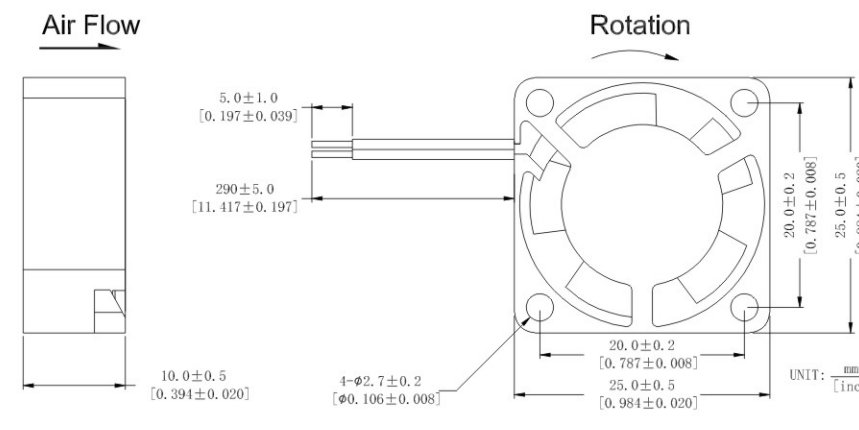

Fan Performance Curve

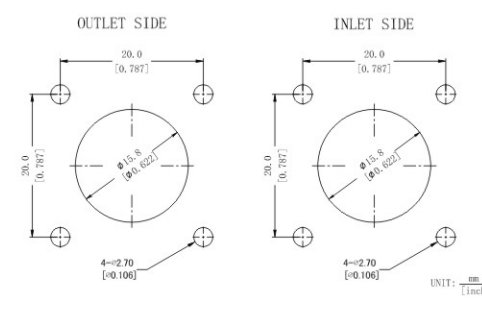
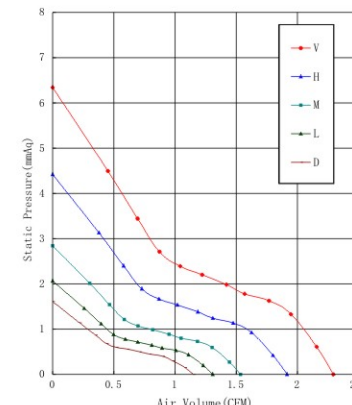

#### 可选的功能参照列表 (Available Functions)

##### 1. 马达保护 (Motor protection)

RP	SS	AS	CL
<input type="checkbox"/>	<input type="checkbox"/>	<input type="checkbox"/>	<input type="checkbox"/>

##### 2. 信号输出 (Signal output)

FG	RD	RD	LD
<input type="checkbox"/>	<input type="checkbox"/>	<input type="checkbox"/>	<input type="checkbox"/>

##### 3. 调速方式 (Speed control mode)

PWM	TP	VC	RC	CS
<input type="checkbox"/>	<input type="checkbox"/>	<input type="checkbox"/>	<input type="checkbox"/>	<input type="checkbox"/>

Part Number	Voltage (V)	Current (A)	Power (W)	Speed (RPM)	Air flow (Q)	Pressure (P)	Noise (dBA)		
产品编号	电压范围	额定电流	功率	转速	(CFM)风量	m <sup>3</sup> /min (mmAq)风压	(In H <sub>2</sub> O) 噪音		
RS2510x05D	5 (4~6)	0.06	0.30	6000	1.15	0.03	1.61	0.06	17.0
RS2510x05L		0.08	0.40	6800	1.31	0.037	2.06	0.08	18.2
RS2510x05M		0.19	0.95	8000	1.53	0.04	2.84	0.11	19.6
RS2510x05H		0.26	1.30	10000	1.91	0.05	4.42	0.17	21.7
RS2510x05VH		0.33	1.65	12000	2.29	0.06	6.34	0.25	24.3
RS2510x12M	12 (7~14)	0.08	0.96	8000	1.53	0.04	2.84	0.11	19.6
RS2510x12H		0.11	1.32	10000	1.91	0.05	4.42	0.17	21.7
RS2510x12VH		0.14	1.68	12000	2.29	0.06	6.34	0.25	24.3

★ 如果您需要的转速或电压或功能不在这份清单上, 请与我们联系。  
If you want another rpm or voltage or functions which one is not in the list, please contact with our sales.

★ 提示1:功能的具体信息参照产品目录前页篇章。  
Notes1:The catalog have detail information in the front page for the functions.

★ 提示2:产品详细信息请参照承认书。  
Notes2:Product have a detail in the approval sheet.

★ 提示3:产品规格变更不另行通知。  
Notes3:Specifications are subject to change without notice.

# DC AXIAL FAN

## 30x30x7mm

### RS3007 Series



外框材质:环保防火PBT  
Frame:Thermoplastic PBT UL94-V0  
扇叶材质:环保防火PBT  
Impeller:Thermoplastic PBT UL94-V0  
轴承结构:双滚珠或长寿命含油结构  
Bearing system:2Ball or Long life sleeve  
单体风扇重量:6g  
Unit Weight:6g

#### 可选的功能参照列表 (Available Functions)

1.马达保护(Motor protection)

RP	SS	AS	CL
<input type="checkbox"/>	<input type="checkbox"/>	<input type="checkbox"/>	<input type="checkbox"/>

2.信号输出(Signal output)

FG	RD	RD	LD
<input type="checkbox"/>	<input type="checkbox"/>	<input type="checkbox"/>	<input type="checkbox"/>

3.调速方式(Speed control mode)

PWM	TP	VC	RC	CS
<input type="checkbox"/>	<input type="checkbox"/>	<input type="checkbox"/>	<input type="checkbox"/>	<input type="checkbox"/>

DIMENSIONS DRAWING

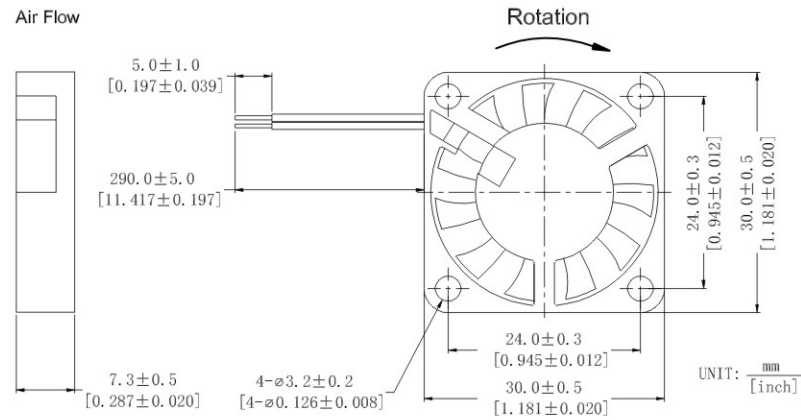

Fan Performance Curve

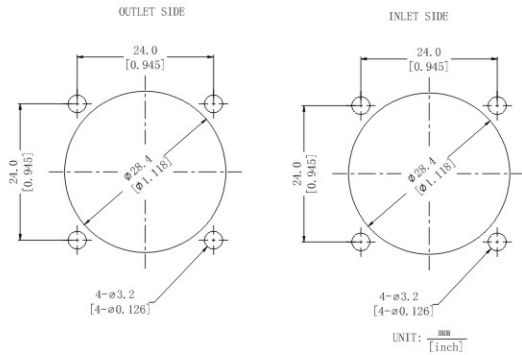
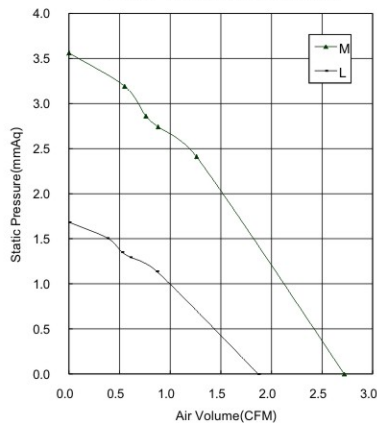

Part Number	Voltage (V)	Current (A)	Power (W)	Speed (RPM)	Air flow (Q)	Pressure (P)	Noise (dBA)		
产品编号	电压范围	额定电流	功率	转速	(CFM)风量	m <sup>3</sup> /min (mmAq)风压	(In H <sub>2</sub> O) 噪音		
RS3007x05D	5(4~6)	0.07	0.35	5500	1.87	0.05	1.68	0.07	26.1
RS3007x05L		0.10	0.50	8000	2.72	0.08	3.56	0.14	30.2

★ 如果您需要的转速或电压或功能不在这份清单上, 请与我们联系。  
If you want another rpm or voltage or functions which one is not in the list, please contact with our sales.

★ 提示1:功能的具体信息参照产品目录前页篇章。  
Notes1:The catalog have detail information in the front page for the functions.

★ 提示2:产品详细信息请参照承认书。  
Notes2:Product have a detail in the approval sheet.

★ 提示3:产品规格变更不另行通知。  
Notes3:Specifications are subject to change without notice.

# DC AXIAL FAN

## 30x30x10mm

### RS3010 Series



外框材质:环保防火PBT  
Frame:Thermoplastic PBT UL94-V0  
扇叶材质:环保防火PBT  
Impeller:Thermoplastic PBT UL94-V0  
轴承结构:双滚珠或长寿命含油结构  
Bearing system:2Ball or Long life sleeve  
单体风扇重量:8g  
Unit Weight:8g

#### 可选的功能参照列表 (Available Functions)

1.马达保护(Motor protection)

RP	SS	AS	CL
<input type="checkbox"/>	<input type="checkbox"/>	<input type="checkbox"/>	<input type="checkbox"/>

2.信号输出(Signal output)

FG	RD	RD	LD
<input type="checkbox"/>	<input type="checkbox"/>	<input type="checkbox"/>	<input type="checkbox"/>

3.调速方式(Speed control mode)

PWM	TP	VC	RC	CS
<input type="checkbox"/>	<input type="checkbox"/>	<input type="checkbox"/>	<input type="checkbox"/>	<input type="checkbox"/>

DIMENSIONS DRAWING

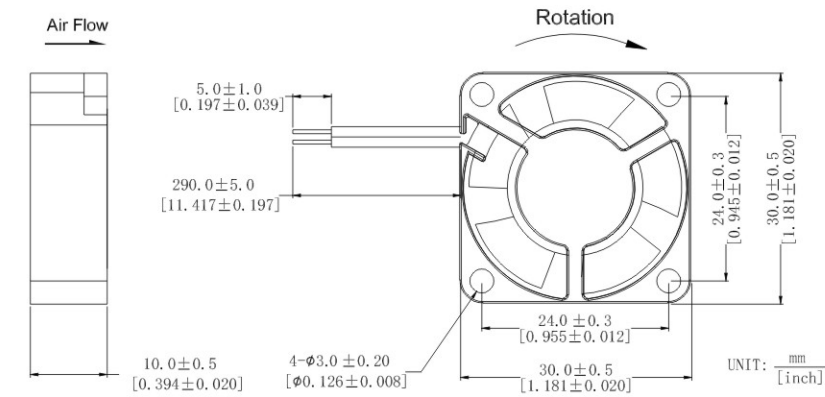

Fan Performance Curve

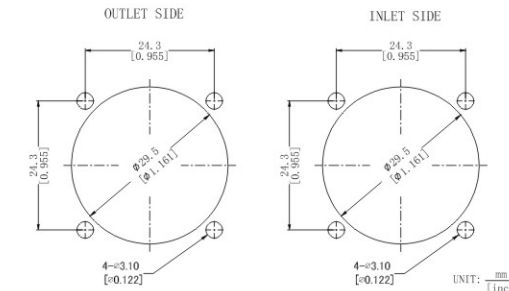
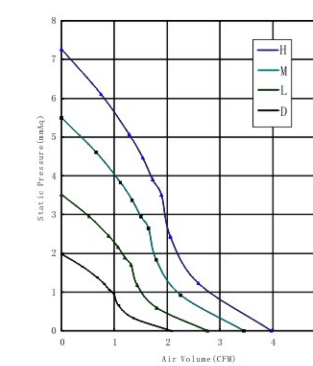

Part Number	Voltage (V)	Current (A)	Power (W)	Speed (RPM)	Air flow (Q)	Pressure (P)	Noise (dBA)		
产品编号	电压范围	额定电流	功率	转速	(CFM) 风量	m <sup>3</sup> /min (mmAq) 风压	(In H <sub>2</sub> O) 噪音		
RS3010x05L	5(4~6)	0.07	0.35	6000	2.07	0.06	1.98	0.08	20.5
RS3010x05M		0.12	0.60	8000	2.76	0.08	3.51	0.14	25.2
RS3010x05H		0.18	0.90	10000	3.45	0.10	5.49	0.22	31.6
RS3010x12L	12(7~14)	0.05	0.60	6000	2.07	0.06	1.98	0.08	20.5
RS3010x12M		0.07	0.84	8000	2.76	0.08	3.51	0.14	25.2
RS3010x12H		0.10	1.20	10000	3.45	0.10	5.49	0.22	31.6
RS3010x12VH		0.13	1.56	11500	3.97	0.11	7.26	0.29	34.0

★ 如果您需要的转速或电压或功能不在这份清单上, 请与我们联系。  
If you want another rpm or voltage or functions which one is not in the list, please contact with our sales.

★ 提示1:功能的具体信息参照产品目录前页篇章。  
Notes1:The catalog have detail information in the front page for the functions.

★ 提示2:产品详细信息请参照承认书。  
Notes2:Product have a detail in the approval sheet.

★ 提示3:产品规格变更不另行通知。  
Notes3:Specifications are subject to change without notice.

## DC AXIAL FAN

### 30x30x10mm RS3010 AJ Series

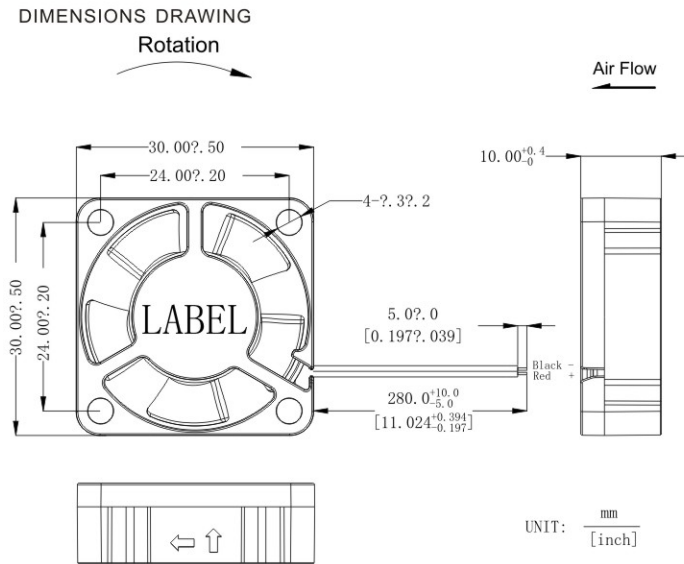

外框材质:环保防火PBT  
Frame:Thermoplastic PBT UL94-V0  
扇叶材质:环保防火PBT  
Impeller:Thermoplastic PBT UL94-V0  
轴承结构:双滚珠或长寿命含油结构  
Bearing system:2Ball or Long life sleeve  
单体风扇重量:10g  
Unit Weight:10g

#### 可选的功能参照列表 (Available Functions)

1.马达保护(Motor protection)

RP	SS	AS	CL
●	●	●	●

2.信号输出(Signal output)

FG	RD	RD	LD
●	●	●	○

3.调速方式(Speed control mode)

PWM	TP	VC	RC	CS
●	○	○	○	○

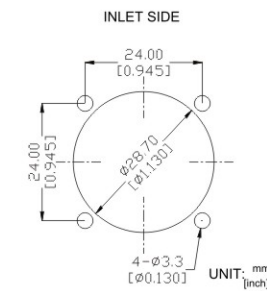
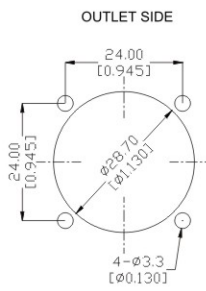
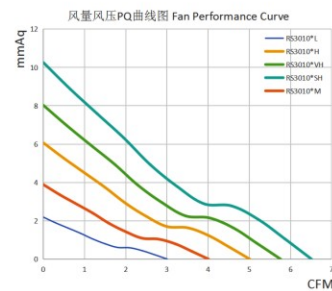

Part Number	Voltage(V)	Current(A)	Power(W)	Speed(RPM)	Air flow(Q)	Pressure(P)	Noise(dBA)
产品编号	电压范围	额定电流	功率	转速	(CFM) 风量	m <sup>3</sup> /min (mmAq)风压 (In H <sub>2</sub> O)	噪音
RS3010x12L	12(7~14)	0.02	0.24	6000	3.01	0.09	22.56
RS3010x12M		0.03	0.36	8000	4.01	0.11	27.38
RS3010x12H		0.04	0.48	10000	5.01	0.14	32.82
RS3010x12VH		0.10	1.20	11500	5.76	0.16	35.60
RS3010x12SH		0.16	1.92	13000	6.51	0.18	39.50
RS3010x24L	24(15~27)	0.01	0.24	6000	3.01	0.09	22.56
RS3010x24M		0.02	0.48	8000	4.01	0.11	27.38
RS3010x24H		0.02	0.48	10000	5.01	0.14	32.82
RS3010x24VH		0.05	1.20	11500	5.76	0.16	35.60
RS3010x24SH		0.08	1.92	13000	6.51	0.18	39.50

★ 如果您需要的转速或电压或功能不在这份清单上, 请与我们联系。  
If you want another rpm or voltage or functions which one is not in the list, please contact with our sales.

★ 提示1:功能的具体信息参照产品目录前页篇章。  
Notes1:The catalog have detail information in the front page for the functions.

★ 提示2:产品详细信息请参照承认书。  
Notes2:Product have a detail in the approval sheet.

★ 提示3:产品规格变更不另行通知。  
Notes3:Specifications are subject to change without notice.

## DC AXIAL FAN

### 35x35x10mm RS3510 Series

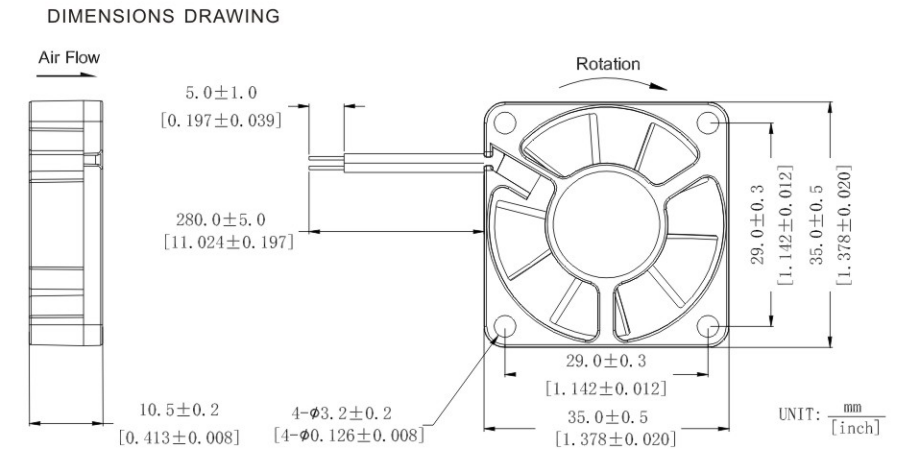

外框材质:环保防火PBT  
Frame:Thermoplastic PBT UL94-V0  
扇叶材质:环保防火PBT  
Impeller:Thermoplastic PBT UL94-V0  
轴承结构:双滚珠或长寿命含油结构  
Bearing system:2Ball or Long life sleeve  
单体风扇重量:10g  
Unit Weight:10g

#### 可选的功能参照列表 (Available Functions)

1.马达保护(Motor protection)

RP	SS	AS	CL
●	○	●	○

2.信号输出(Signal output)

FG	RD	RD	LD
●	●	●	○

3.调速方式(Speed control mode)

PWM	TP	VC	RC	CS
●	○	○	○	○

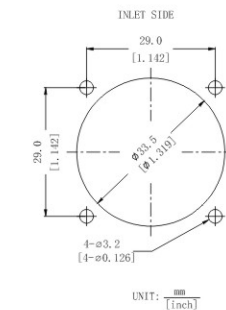
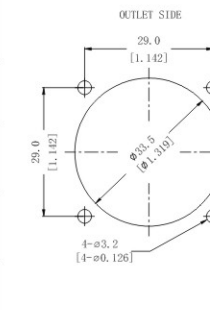
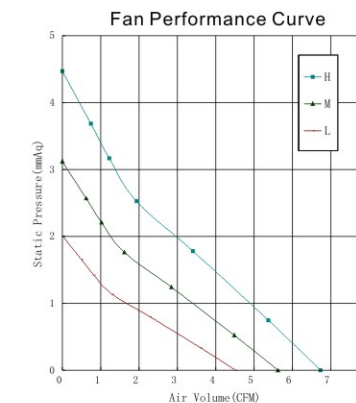

Part Number	Voltage(V)	Current(A)	Power(W)	Speed(RPM)	Air flow(Q)	Pressure(P)	Noise(dBA)
产品编号	电压范围	额定电流	功率	转速	(CFM) 风量	m <sup>3</sup> /min (mmAq)风压 (In H <sub>2</sub> O)	噪音
RS3510x05L	5(4~6)	0.1	0.5	6000	4.50	0.13	18.0
RS3510x05M		0.15	0.75	7500	5.62	0.16	21.0
RS3510x05H		0.19	0.95	9000	6.43	0.18	25.0
RS3510x12L	12(7~14)	0.06	0.72	6000	4.50	0.13	18.0
RS3510x12M		0.09	1.08	7500	5.62	0.16	21.0
RS3510x12H		0.11	1.32	9000	6.43	0.18	25.0

★ 如果您需要的转速或电压或功能不在这份清单上, 请与我们联系。  
If you want another rpm or voltage or functions which one is not in the list, please contact with our sales.

★ 提示1:功能的具体信息参照产品目录前页篇章。  
Notes1:The catalog have detail information in the front page for the functions.

★ 提示2:产品详细信息请参照承认书。  
Notes2:Product have a detail in the approval sheet.

★ 提示3:产品规格变更不另行通知。  
Notes3:Specifications are subject to change without notice.

## DC AXIAL FAN

### 40x40x10mm RS4010 Series



外框材质:环保防火PBT  
Frame:Thermoplastic PBT UL94-V0  
扇叶材质:环保防火PBT  
Imperller:Thermoplastic PBT UL94-V0  
轴承结构:双滚珠或长寿命含油结构  
Bearing system:2Ball or Long life sleeve  
单体风扇重量:12g  
Unit Weight:12g

DIMENSIONS DRAWING

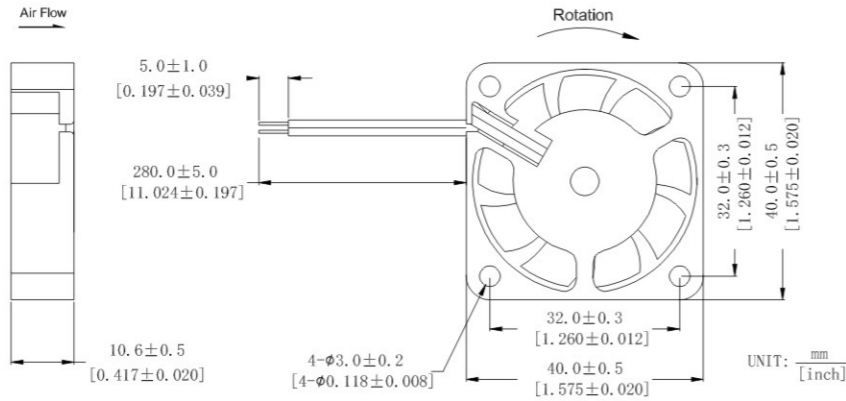

Fan Performance Curve

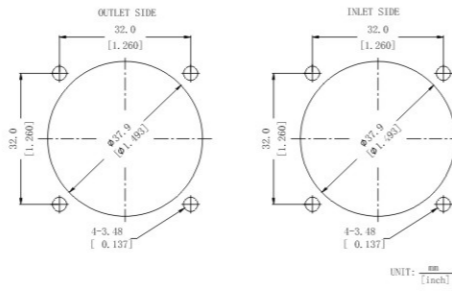
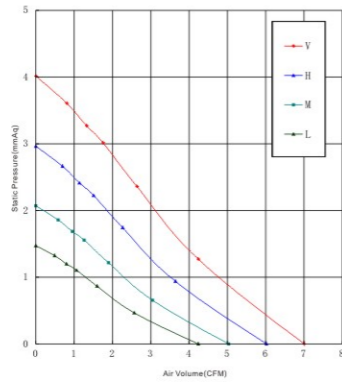

#### 可选的功能参照列表 (Available Functions)

##### 1.马达保护(Motor protection)

RP	SS	AS	CL
●	○	●	○

##### 2.信号输出(Signal output)

FG	RD	RD	LD
●	●	●	○

##### 3.调速方式(Speed control mode)

PWM	TP	VC	RC	CS
●	○	○	○	○

Part Number	Voltage(V)	Current(A)	Power(W)	Speed(RPM)	Air flow(Q)	Pressure(P)	Noise(dBA)
产品编号	电压范围	额定电流	功率	转速	(CFM)风量	(mmAq)风压	(In H <sub>2</sub> O) 噪音
RS4010x05L	5(4~5.5)	0.14	0.70	4200	4.24	0.12	31.5
RS4010x05M		0.19	0.95	5000	5.03	0.14	32.9
RS4010x05H		0.29	1.45	6000	6.02	0.17	36.0
RS4010x05VH		0.34	1.70	7000	7.04	0.20	39.1
RS4010x12L		12(7~14)	0.06	0.72	4200	4.24	0.12
RS4010x12M	0.08		0.96	5000	5.03	0.14	32.9
RS4010x12H	0.12		1.44	6000	6.02	0.17	36.0
RS4010x12VH	0.14		1.68	7000	7.04	0.20	39.1
RS4010x24M	24(15~27)	0.04	0.96	5000	5.03	0.14	32.9
RS4010x24H		0.06	1.44	6000	6.02	0.17	36.0
RS4010x24VH		0.07	1.68	7000	7.04	0.20	39.1

★ 如果您需要的转速或电压或功能不在这份清单上, 请与我们联系。  
If you want another rpm or voltage or functions which one is not in the list, please contact with our sales.

★ 提示1:功能的具体信息参照产品目录前页篇章。  
Notes1: The catalog have detail information in the front page for the functions.

★ 提示2:产品详细信息请参照承诺书。  
Notes2: Product have a detail in the approval sheet.

★ 提示3:产品规格变更不另行通知。  
Notes3: Specifications are subject to change without notice.

★ 提示4:调速方式只能制作12V机型。  
Note4: Speed control mode only for 12V products.

## DC AXIAL FAN

### 40x40x10mm RS4010-B Series



外框材质:环保防火PBT  
Frame:Thermoplastic PBT UL94-V0  
扇叶材质:环保防火PBT  
Imperller:Thermoplastic PBT UL94-V0  
轴承结构:双滚珠或长寿命含油结构  
Bearing system:2Ball or Long life sleeve  
单体风扇重量:16g  
Unit Weight:16g

#### 可选的功能参照列表 (Available Functions)

##### 1.马达保护(Motor protection)

RP	SS	AS	CL
●	○	●	○

##### 2.信号输出(Signal output)

FG	RD	RD	LD
●	●	●	○

##### 3.调速方式(Speed control mode)

PWM	TP	VC	RC	CS
●	○	○	○	○

DIMENSIONS DRAWING

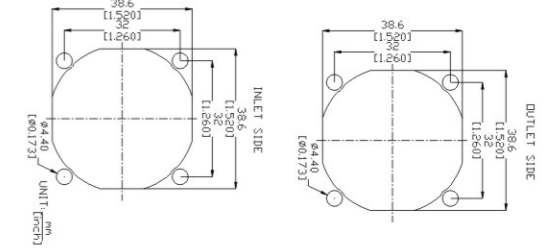
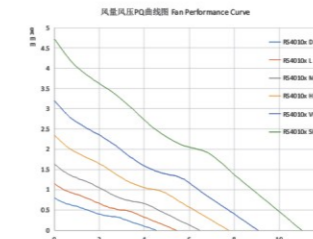
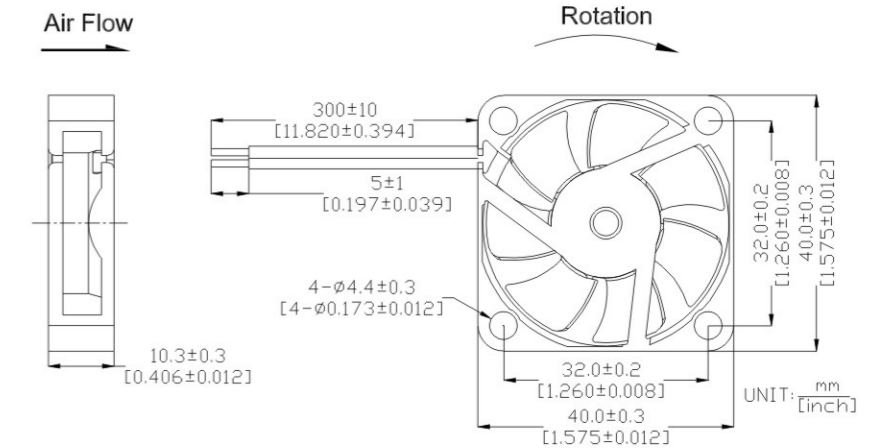

Part Number	Voltage(V)	Current(A)	Power(W)	Speed(RPM)	Air flow(Q)	Pressure(P)	Noise(dBA)
产品编号	电压范围	额定电流	功率	转速	(CFM)风量	(mmAq)风压	(In H <sub>2</sub> O) 噪音
RS4010x05D	5(3.5~6)	0.08	0.4	3500	4.38	0.12	15.49
RS4010x05L		0.12	0.6	4200	5.25	0.15	19.45
RS4010x05M		0.16	0.8	5000	6.25	0.18	23.24
RS4010x05H		0.23	1.15	6000	7.50	0.21	27.20
RS4010x05VH		0.27	1.35	7000	8.75	0.25	30.54
RS4010x05SH		0.35	1.75	8500	10.63	0.30	34.76
RS4010x12D	12(7~14)	0.03	0.36	3500	4.38	0.12	15.49
RS4010x12L		0.05	0.60	4200	5.25	0.15	19.45
RS4010x12M		0.07	0.84	5000	6.25	0.18	23.24
RS4010x12H		0.10	1.20	6000	7.50	0.21	27.20
RS4010x12VH		0.11	1.32	7000	8.75	0.25	30.54
RS4010x12SH		0.15	1.80	8500	10.63	0.30	34.76
RS4010x24D	24(15~27)	0.02	0.48	3500	4.38	0.12	15.49
RS4010x24L		0.03	0.72	4200	5.25	0.15	19.45
RS4010x24M		0.03	0.72	5000	6.25	0.18	23.24
RS4010x24H		0.05	1.2	6000	7.50	0.21	27.20
RS4010x24VH		0.06	1.44	7000	8.75	0.25	30.54
RS4010x24SH		0.07	1.68	8500	10.63	0.30	34.76

★ 如果您需要的转速或电压或功能不在这份清单上, 请与我们联系。  
If you want another rpm or voltage or functions which one is not in the list, please contact with our sales.

★ 提示1:功能的具体信息参照产品目录前页篇章。  
Notes1: The catalog have detail information in the front page for the functions.

★ 提示2:产品详细信息请参照承诺书。  
Notes2: Product have a detail in the approval sheet.

★ 提示3:产品规格变更不另行通知。  
Notes3: Specifications are subject to change without notice.

## DC AXIAL FAN

### 40x40x15mm RS4015 Series



外框材质:环保防火PBT  
Frame:Thermoplastic PBT UL94-V0  
扇叶材质:环保防火PBT  
Impeller:Thermoplastic PBT UL94-V0  
轴承结构:双滚珠或长寿命含油结构  
Bearing system:2Ball or Long life sleeve  
单体风扇重量:17g  
Unit Weight:17g

DIMENSIONS DRAWING

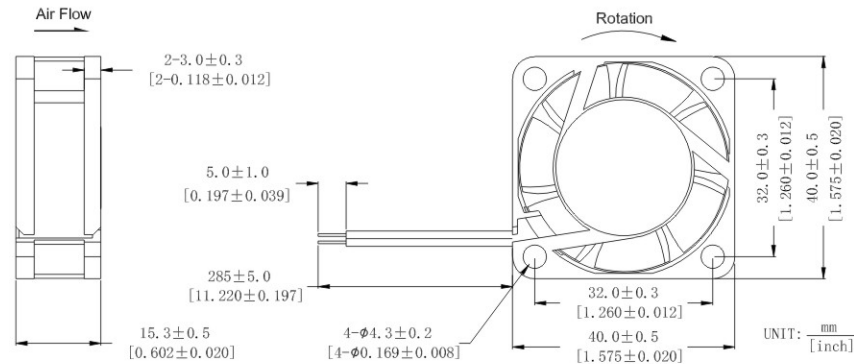

Fan Performance Curve

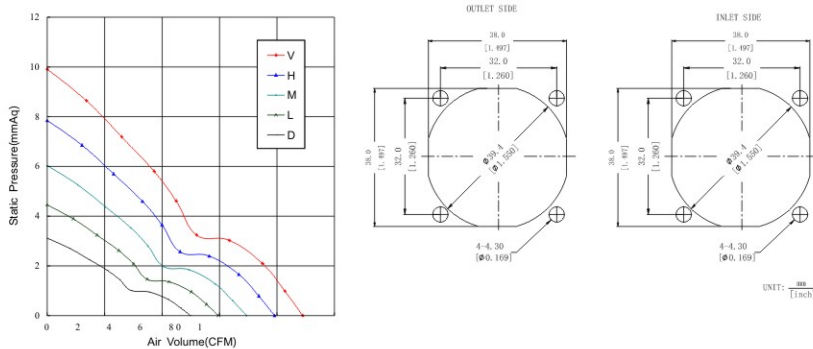

可选的功能参照列表  
(Available Functions)

1.马达保护(Motor protection)

RP	SS	AS	CL
<input type="checkbox"/>	<input type="checkbox"/>	<input type="checkbox"/>	<input type="checkbox"/>

2.信号输出(Signal output)

FG	RD	RD	LD
<input type="checkbox"/>	<input type="checkbox"/>	<input type="checkbox"/>	<input type="checkbox"/>

3.调速方式(Speed control mode)

PWM	TP	VC	RC	CS
<input type="checkbox"/>	<input type="checkbox"/>	<input type="checkbox"/>	<input type="checkbox"/>	<input type="checkbox"/>

Part Number	Voltage(V)	Current(A)	Power(W)	Speed(RPM)	Air flow(Q)	Pressure(P)	Noise(dBA)		
产品编号	电压范围	额定电流	功率	转速	(CFM)风量	m <sup>3</sup> /min	(mmAq)风压	( In H <sub>2</sub> O)	噪音
RS4015x05D	5(4~6)	0.12	0.6	5000	5.00	0.14	3.10	0.12	18.6
RS4015x05L		0.15	0.75	6000	6.00	0.17	4.50	0.18	23.3
RS4015x05M		0.24	1.2	7000	6.90	0.20	6.00	0.24	27.3
RS4015x05H		0.32	1.6	8000	7.90	0.22	7.80	0.31	30.8
RS4015x12L	12(7~14)	0.05	0.6	6000	6.00	0.17	4.50	0.18	23.3
RS4015x12M		0.1	1.2	7000	6.90	0.20	6.00	0.24	27.3
RS4015x12H		0.14	1.68	8000	7.90	0.22	7.80	0.31	30.8
RS4015x12VH		0.16	1.92	9000	8.90	0.25	9.90	0.39	33.9
RS4015x24M	24(15~27)	0.06	1.44	7000	6.90	0.20	6.00	0.24	27.3
RS4015x24H		0.07	1.68	8000	7.90	0.22	7.80	0.31	30.8
RS4015x24VH		0.08	1.92	9000	8.90	0.25	9.90	0.39	33.9

★如果您需要的转速或电压或功能不在这份清单上, 请与我们联系。  
If you want another rpm or voltage or functions which one is not in the list, please contact with our sales.

★提示1:功能的具体信息参照产品目录前页篇章。  
Notes1:The catalog have detail information in the front page for the functions.

★提示2:产品详细信息请参照承认书。  
Notes2:Product have a detail in the approval sheet.

★提示3:产品规格变更不另行通知。  
Notes3:Specifications are subject to change without notice.

★提示4:调速方式只能制作12V机型。  
Note4:Speed control mode only for 12V products.

## DC AXIAL FAN

### 40x40x20mm RS4020 Series



外框材质:环保防火PBT  
Frame:Thermoplastic PBT UL94-V0  
扇叶材质:环保防火PBT  
Impeller:Thermoplastic PBT UL94-V0  
轴承结构:双滚珠或长寿命含油结构  
Bearing system:2Ball or Long life sleeve  
单体风扇重量:24g  
Unit Weight:24g

DIMENSIONS DRAWING

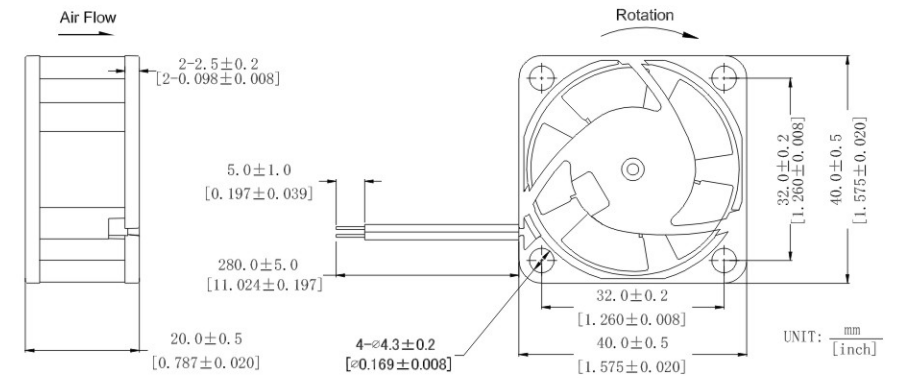

Fan Performance Curve

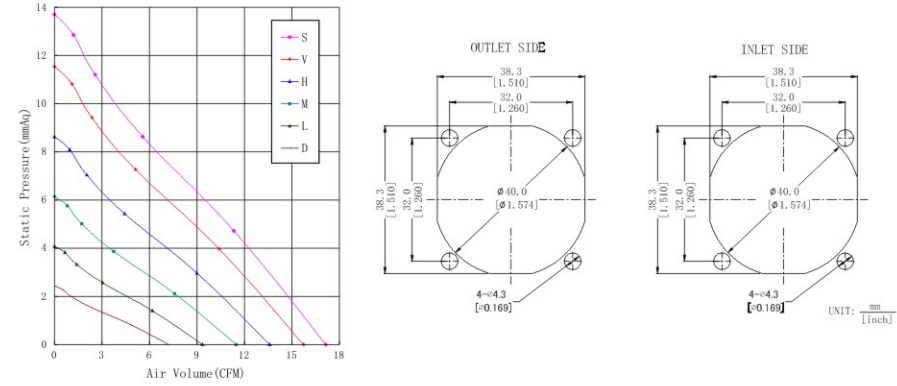

可选的功能参照列表  
(Available Functions)

1.马达保护(Motor protection)

RP	SS	AS	CL
<input type="checkbox"/>	<input type="checkbox"/>	<input type="checkbox"/>	<input type="checkbox"/>

2.信号输出(Signal output)

FG	RD	RD	LD
<input type="checkbox"/>	<input type="checkbox"/>	<input type="checkbox"/>	<input type="checkbox"/>

3.调速方式(Speed control mode)

PWM	TP	VC	RC	CS
<input type="checkbox"/>	<input type="checkbox"/>	<input type="checkbox"/>	<input type="checkbox"/>	<input type="checkbox"/>

Part Number	Voltage(V)	Current(A)	Power(W)	Speed(RPM)	Air flow(Q)	Pressure(P)	Noise(dBA)		
产品编号	电压范围	额定电流	功率	转速	(CFM)风量	m <sup>3</sup> /min	(mmAq)风压	( In H <sub>2</sub> O)	噪音
RS4020x05D	5(4~6)	0.10	0.50	5000	7.23	0.20	2.43	0.10	21.3
RS4020x05L		0.14	0.70	6500	9.35	0.26	4.07	0.16	26.5
RS4020x05M		0.24	1.20	8000	11.47	0.32	6.14	0.24	29.8
RS4020x12D		12(7~14)	0.04	0.48	5000	7.23	0.20	2.43	0.10
RS4020x12L	0.06		0.72	6500	9.35	0.26	4.07	0.16	26.5
RS4020x12M	0.10		1.20	8000	11.47	0.32	6.14	0.24	29.8
RS4020x12H	0.16		1.92	9500	13.60	0.38	8.63	0.34	35.1
RS4020x12VH	24(15~27)	0.22	2.64	11000	15.73	0.45	11.54	0.45	39.1
RS4020x12SH		0.30	3.60	12000	17.14	0.49	13.71	0.54	41.0
RS4020x24M		0.05	1.20	8000	11.47	0.32	6.14	0.24	29.8
RS4020x24H		0.08	1.92	9500	13.60	0.38	8.63	0.34	35.1
RS4020x24VH	24(15~27)	0.11	2.64	11000	15.73	0.45	11.54	0.45	39.1
RS4020x24SH		0.15	3.60	12000	17.14	0.49	13.71	0.54	41.0

★如果您需要的转速或电压或功能不在这份清单上, 请与我们联系。  
If you want another rpm or voltage or functions which one is not in the list, please contact with our sales.

★提示1:功能的具体信息参照产品目录前页篇章。  
Notes1:The catalog have detail information in the front page for the functions.

★提示2:产品详细信息请参照承认书。  
Notes2:Product have a detail in the approval sheet.

★提示3:产品规格变更不另行通知。  
Notes3:Specifications are subject to change without notice.

★提示4:调速方式只能制作12V机型。  
Note4:Speed control mode only for 12V products.

# DC AXIAL FAN

## 40x40x28mm

### RD4028 Series



DIMENSIONS DRAWING

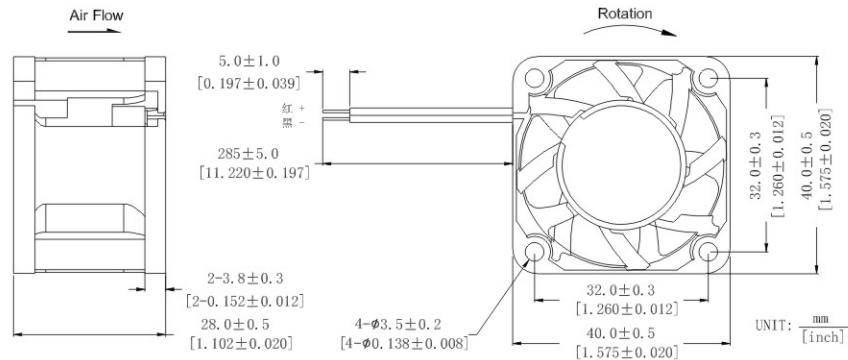

外框材质:环保防火PBT  
Frame:Thermoplastic PBT UL94-V0  
扇叶材质:环保防火PBT  
Impeller:Thermoplastic PBT UL94-V0  
轴承结构:双滚珠或长寿命含油结构  
Bearing system:2Ball or Long life sleeve  
单体风扇重量:50g  
Unit Weight:50g

#### 可选的功能参照列表 (Available Functions)

##### 1. 马达保护 (Motor protection)

RP	SS	AS	CL
●	○	●	○

##### 2. 信号输出 (Signal output)

FG	RD	RD	LD
●	●	○	○

##### 3. 调速方式 (Speed control mode)

PWM	TP	VC	RC	CS
●	○	○	○	○

Fan Performance Curve

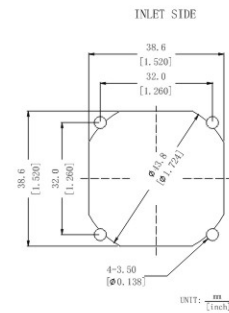
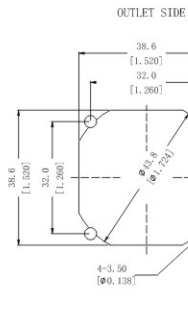
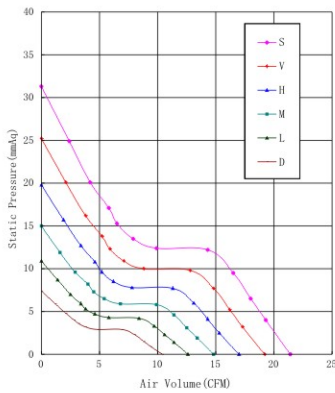

Part Number	Voltage(V)	Current(A)	Power(W)	Speed(RPM)	Air flow(Q)		Pressure(P)		Noise(dBA)	
产品编号	电压范围	额定电流	功率	转速	(CFM) 风量	m <sup>3</sup> /min	(mmAq)风压	(In H <sub>2</sub> O)	噪音	
RD4028x12D	12(7~14)	0.10	1.20	7000	10.40	0.29	7.40	0.29	33.5	
RD4028x12L		0.12	1.44	8500	12.60	0.36	10.90	0.43	36.4	
RD4028x12M		0.20	2.40	10000	14.80	0.42	15.00	0.59	42.1	
RD4028x12H		0.26	3.12	11500	17.00	0.48	19.80	0.78	43.9	
RD4028x12VH		0.34	4.08	13000	19.20	0.54	25.20	0.99	48.3	
RD4028x12SH		0.60	7.20	14500	21.40	0.61	31.30	1.23	51.2	
RD4028x24D		24(15~27)	0.05	1.20	7000	10.40	0.29	7.40	0.29	33.5
RD4028x24L			0.06	1.44	8500	12.60	0.36	10.90	0.43	36.4
RD4028x24M	0.10		2.40	10000	14.80	0.42	15.00	0.59	42.1	
RD4028x24H	0.13		3.12	11500	17.00	0.48	19.80	0.78	43.9	
RD4028x24VH	0.17		4.08	13000	19.20	0.54	25.20	0.99	48.3	
RD4028x24SH	0.30		7.20	14500	21.40	0.61	31.30	1.23	51.2	

★ 如果您需要的转速或电压或功能不在这份清单上, 请与我们联系。  
If you want another rpm or voltage or functions which one is not in the list, please contact with our sales.

★ 提示1:功能的具体信息参照产品目录前页篇章。  
Notes1:The catalog have detail information in the front page for the functions.

★ 提示2:产品详细信息请参照承认书。  
Notes2:Product have a detail in the approval sheet.

★ 提示3:产品规格变更不另行通知。  
Notes3:Specifications are subject to change without notice.

★ 提示4:调速方式只能制作12V机型。  
Note4:Speed control mode only for 12V products.

# DC AXIAL FAN

## 40x40x28mm

### RD4028-B Series



DIMENSIONS DRAWING

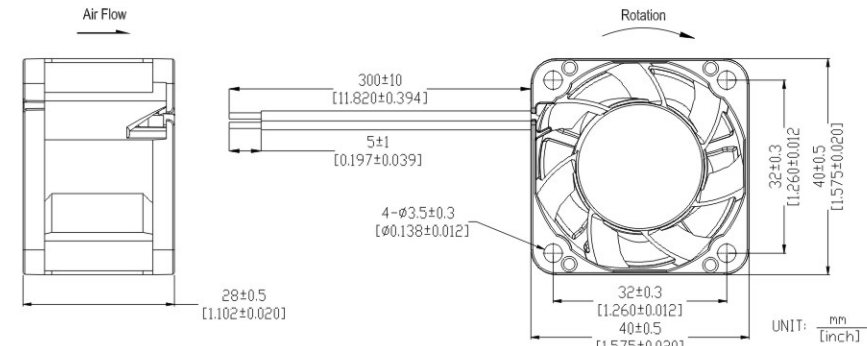

外框材质:环保防火PBT  
Frame:Thermoplastic PBT UL94-V0  
扇叶材质:环保防火PBT  
Impeller:Thermoplastic PBT UL94-V0  
轴承结构:双滚珠或长寿命含油结构  
Bearing system:2Ball or Long life sleeve  
单体风扇重量:50g  
Unit Weight:50g

#### 可选的功能参照列表 (Available Functions)

##### 1. 马达保护 (Motor protection)

RP	SS	AS	CL
●	●	●	●

##### 2. 信号输出 (Signal output)

FG	RD	RD	LD
●	●	○	○

##### 3. 调速方式 (Speed control mode)

PWM	TP	VC	RC	CS
●	●	●	●	●

Fan Performance Curve

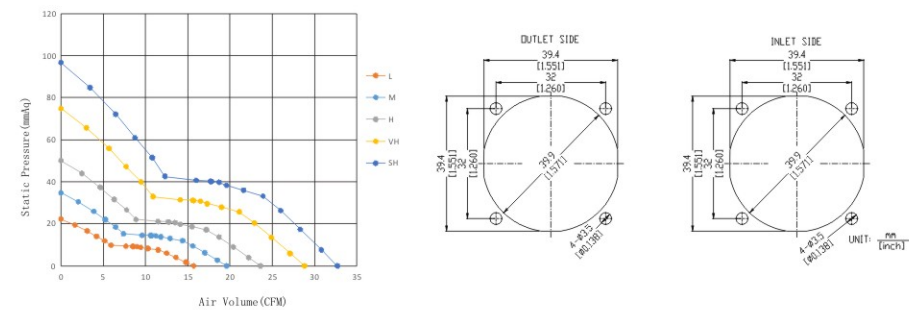

Part Number	Voltage(V)	Current(A)	Power(W)	Speed(RPM)	Air flow(Q)		Pressure(P)		Noise(dBA)	
产品编号	电压范围	额定电流	功率	转速	(CFM) 风量	m <sup>3</sup> /min	(mmAq)风压	(In H <sub>2</sub> O)	噪音	
RD4028B12L	12(7~14)	0.24	2.88	12000	15.7	0.44	22.27	0.88	45	
RD4028B12M		0.37	4.44	15000	19.63	0.56	34.8	1.37	49.2	
RD4028B12H		0.65	7.8	18000	23.55	0.67	50.11	1.97	53.6	
RD4028B12VH		1.05	12.6	22000	28.79	0.81	74.85	2.95	55.7	
RD4028B12SH		1.40	16.8	25000	32.71	0.93	96.66	3.81	60.5	
RD4028B24L		24(15~27)	0.12	2.88	12000	15.7	0.44	22.27	0.88	45
RD4028B24M			0.19	4.44	15000	19.63	0.56	34.8	1.37	49.2
RD4028B24H			0.32	7.8	18000	23.55	0.67	50.11	1.97	53.6
RD4028B24VH	0.52		12.6	22000	28.79	0.81	74.85	2.95	55.7	
RD4028B24SH	0.70		16.8	25000	32.71	0.93	96.66	3.81	60.5	
RD4028B48L	48(35~57)		0.06	2.88	12000	15.7	0.44	22.27	0.88	45
RD4028B48M		0.09	4.44	15000	19.63	0.56	34.8	1.37	49.2	
RD4028B48H		0.16	7.8	18000	23.55	0.67	50.11	1.97	53.6	
RD4028B48VH		0.26	12.6	22000	28.79	0.81	74.85	2.95	55.7	
RD4028B48SH		0.35	16.8	25000	32.71	0.93	96.66	3.81	60.5	

★ 如果您需要的转速或电压或功能不在这份清单上, 请与我们联系。  
If you want another rpm or voltage or functions which one is not in the list, please contact with our sales.

★ 提示1:功能的具体信息参照产品目录前页篇章。  
Notes1:The catalog have detail information in the front page for the functions.

★ 提示2:产品详细信息请参照承认书。  
Notes2:Product have a detail in the approval sheet.

★ 提示3:产品规格变更不另行通知。  
Notes3:Specifications are subject to change without notice.

★ 提示4:调速方式只能制作12V机型。  
Note4:Speed control mode only for 12V products.

# DC AXIAL FAN

## 40x40x56mm RD4056 Series



外框材质:环保防火PBT  
Frame:Thermoplastic PBT UL94-V0  
扇叶材质:环保防火PBT  
Impeller:Thermoplastic PBT UL94-V0  
轴承结构:双滚珠  
Bearing system:2Ball  
单体风扇重量:62g  
Unit Weight:62g

### 可选的功能参照列表 (Available Functions)

#### 1. 马达保护(Motor protection)

RP	SS	AS	CL
●	●	●	●

#### 2. 信号输出(Signal output)

FG	RD	RD	LD
●	●	●	●

#### 3. 调速方式(Speed control mode)

PWM	TP	VC	RC	CS
●	●	●	●	●

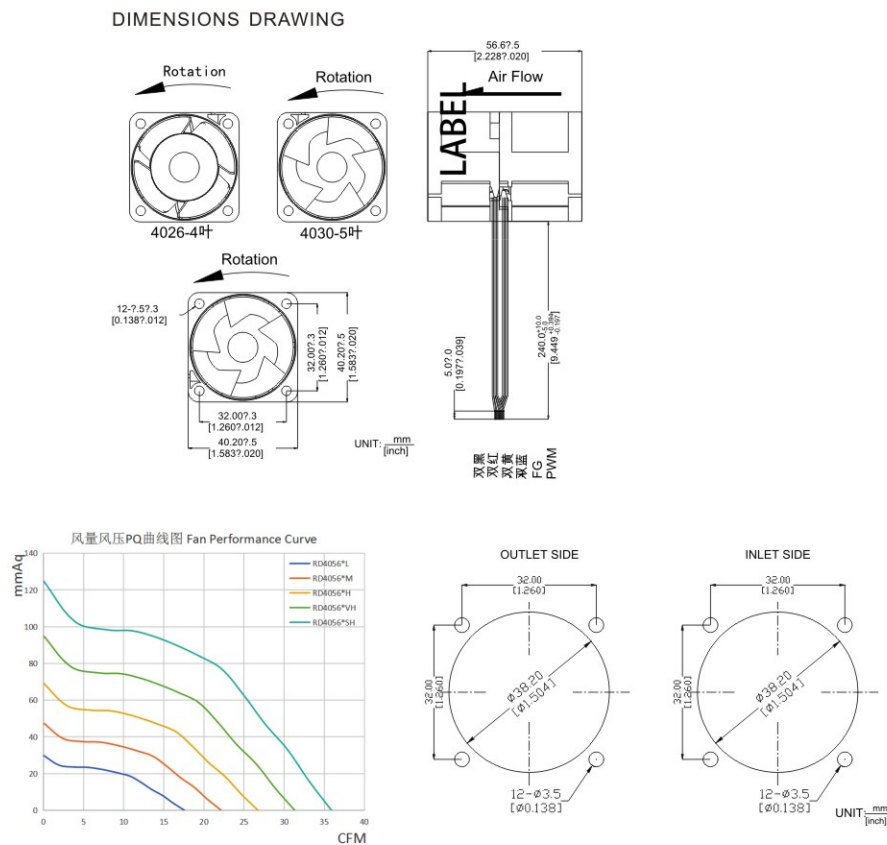

Part Number	Voltage(V)	Current(A)	Power(W)	Speed(RPM)	Air flow(Q)	Pressure(P)	Noise(dBA)		
产品编号	电压范围	额定电流	功率	转速	(CFM)风量	m <sup>3</sup> /min	(mmAq)风压 (In H <sub>2</sub> O)	噪音	
RD4056B12L	12(7~14)	1.22	14.64	23000	17.57	0.50	29.91	1.18	56.00
RD4056B12M		1.50	18.00	29000	22.15	0.63	47.55	1.87	58.80
RD4056B12H		1.72	20.64	35000	26.74	0.76	69.26	2.73	61.74
RD4056B12VH		1.95	23.40	41000	31.32	0.89	95.04	3.74	64.83
RD4056B12SH		2.20	26.40	47000	35.90	1.02	124.90	4.92	68.07
RD4056B24L	24(15~27)	0.61	14.64	23000	17.57	0.50	29.91	1.18	56.00
RD4056B24M		0.75	18.00	29000	22.15	0.63	47.55	1.87	58.80
RD4056B24H		0.86	20.64	35000	26.74	0.76	69.26	2.73	61.74
RD4056B24VH		0.98	23.52	41000	31.32	0.89	95.04	3.74	64.83
RD4056B24SH		1.10	26.40	47000	35.90	1.02	124.90	4.92	68.07
RD4056B48L	48(35~57)	0.31	14.88	23000	17.57	0.50	29.91	1.18	56.00
RD4056B48M		0.38	18.24	29000	22.15	0.63	47.55	1.87	58.80
RD4056B48H		0.43	20.64	35000	26.74	0.76	69.26	2.73	61.74
RD4056B48VH		0.49	23.52	41000	31.32	0.89	95.04	3.74	64.83
RD4056B48SH		0.55	26.40	47000	35.90	1.02	124.90	4.92	68.07

★ 如果您需要的转速或电压或功能不在这份清单上, 请与我们联系。  
If you want another rpm or voltage or functions which one is not in the list, please contact with our sales.

★ 提示1:功能的具体信息参照产品目录前页篇章。  
Notes1:The catalog have detail information in the front page for the functions.

★ 提示2:产品详细信息请参照承认书。  
Notes2:Product have a detail in the approval sheet.

★ 提示3:产品规格变更不另行通知。  
Notes3:Specifications are subject to change without notice.

★ 提示4:调速方式只能制作12V机型。  
Note4:Speed control mode only for 12V products.

# DC AXIAL FAN

## 50x50x10mm RS5010 Series



外框材质:环保防火PBT  
Frame:Thermoplastic PBT UL94-V0  
扇叶材质:环保防火PBT  
Impeller:Thermoplastic PBT UL94-V0  
轴承结构:双滚珠或长寿命含油结构  
Bearing system:2Ball or Long life sleeve  
单体风扇重量:16g  
Unit Weight:16g

### 可选的功能参照列表 (Available Functions)

#### 1. 马达保护(Motor protection)

RP	SS	AS	CL
●	○	●	○

#### 2. 信号输出(Signal output)

FG	RD	RD	LD
●	○	○	○

#### 3. 调速方式(Speed control mode)

PWM	TP	VC	RC	CS
●	○	○	○	○

### DIMENSIONS DRAWING

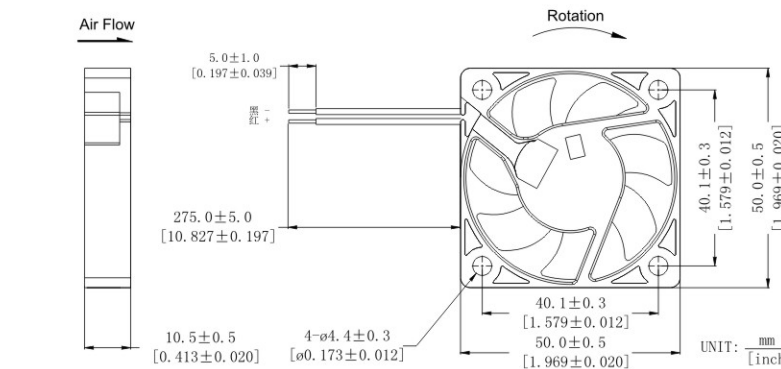

### Fan Performance Curve

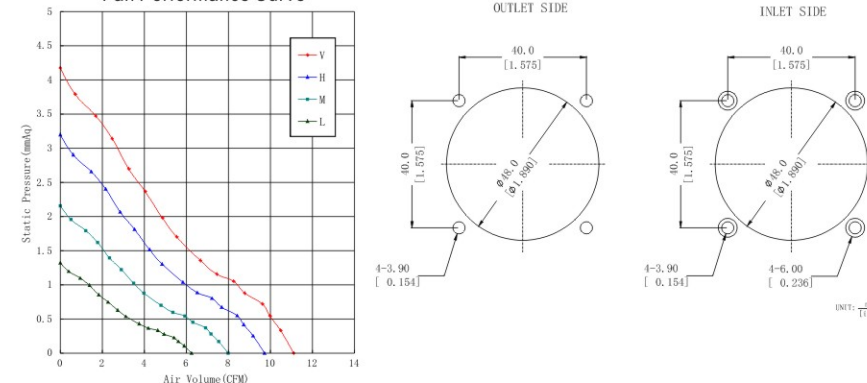

Part Number	Voltage(V)	Current(A)	Power(W)	Speed(RPM)	Air flow(Q)	Pressure(P)	Noise(dBA)		
产品编号	电压范围	额定电流	功率	转速	(CFM)风量	m <sup>3</sup> /min	(mmAq)风压 (In H <sub>2</sub> O)	噪音	
RS5010x05L	5(4~6)	0.08	0.4	3500	6.25	0.18	1.32	0.05	19.0
RS5010x05M		0.17	0.85	4500	7.98	0.23	2.16	0.09	25.8
RS5010x05H		0.25	1.25	5500	9.72	0.28	3.20	0.13	31.8
RS5010x12L	12(7~14)	0.05	0.6	3500	6.25	0.18	1.32	0.05	19.0
RS5010x12M		0.09	1.08	4500	7.98	0.23	2.16	0.09	25.8
RS5010x12H		0.13	1.56	5500	9.72	0.28	3.20	0.13	31.8
RS5010x12VH		0.15	1.8	6300	11.10	0.31	4.18	0.16	34.0
RS5010x24M		24(15~27)	0.05	1.2	4500	7.98	0.23	2.16	0.09
RS5010x24H	0.07		1.68	5500	9.72	0.28	3.20	0.13	31.8
RS5010x24VH	0.1		2.4	6300	11.10	0.31	4.18	0.16	34.0

★ 如果您需要的转速或电压或功能不在这份清单上, 请与我们联系。  
If you want another rpm or voltage or functions which one is not in the list, please contact with our sales.

★ 提示1:功能的具体信息参照产品目录前页篇章。  
Notes1:The catalog have detail information in the front page for the functions.

★ 提示2:产品详细信息请参照承认书。  
Notes2:Product have a detail in the approval sheet.

★ 提示3:产品规格变更不另行通知。  
Notes3:Specifications are subject to change without notice.

★ 提示4:调速方式只能制作12V机型。  
Note4:Speed control mode only for 12V products.

# DC AXIAL FAN

## 50x50x15mm

### RS5015 Series



外框材质:环保防火PBT  
Frame:Thermoplastic PBT UL94-V0  
扇叶材质:环保防火PBT  
Impeller:Thermoplastic PBT UL94-V0  
轴承结构:双滚珠或长寿命含油结构  
Bearing system:2Ball or Long life sleeve  
单体风扇重量:24g  
Unit Weight:24g

#### 可选的功能参照列表 (Available Functions)

##### 1. 马达保护 (Motor protection)

RP	SS	AS	CL
<input type="checkbox"/>	<input type="checkbox"/>	<input type="checkbox"/>	<input type="checkbox"/>

##### 2. 信号输出 (Signal output)

FG	RD	RD	LD
<input type="checkbox"/>	<input type="checkbox"/>	<input type="checkbox"/>	<input type="checkbox"/>

##### 3. 调速方式 (Speed control mode)

PWM	TP	VC	RC	CS
<input type="checkbox"/>	<input type="checkbox"/>	<input type="checkbox"/>	<input type="checkbox"/>	<input type="checkbox"/>

DIMENSIONS DRAWING

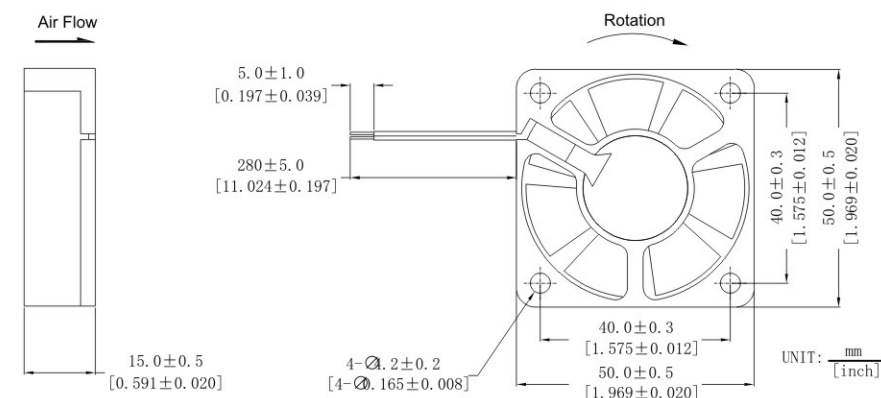

Fan Performance Curve

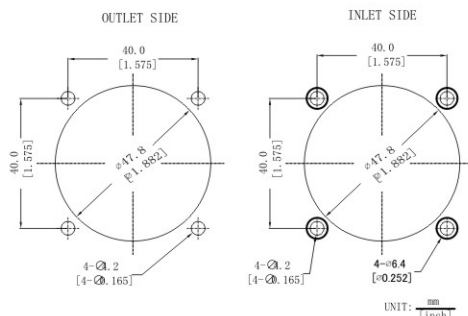
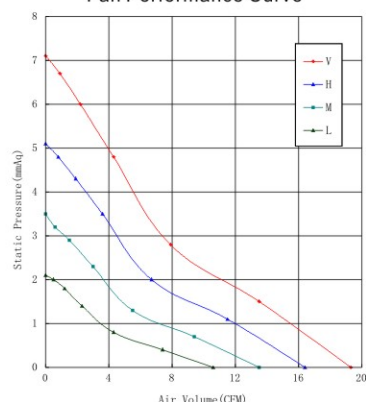

Part Number	Voltage(V)	Current(A)	Power(W)	Speed(RPM)	Air flow(Q)	Pressure(P)	Noise(dBA)
产品编号	电压范围	额定电流	功率	转速	(CFM)风量	m <sup>3</sup> /min	(mmAq)风压
RS5015x05L	5(4~6)	0.12	0.60	3500	10.55	0.30	2.12
RS5015x05M		0.18	0.90	4500	13.48	0.38	3.46
RS5015x05H		0.34	1.70	5500	16.41	0.46	5.13
RS5015x12L	12(7~14)	0.06	0.72	3500	10.55	0.30	2.12
RS5015x12M		0.09	1.08	4500	13.48	0.38	3.46
RS5015x12H		0.14	1.68	5500	16.41	0.46	5.13
RS5015x12VH	24(15~27)	0.19	2.28	6500	19.35	0.55	7.12
RS5015x24H		0.07	1.68	5500	16.41	0.46	5.13
RS5015x24VH		0.10	2.40	6500	19.35	0.55	7.12

★ 如果您需要的转速或电压或功能不在这份清单上, 请与我们联系。  
If you want another rpm or voltage or functions which one is not in the list, please contact with our sales.

★ 提示1: 功能的具体信息参照产品目录前页篇章。  
Notes1: The catalog have detail information in the front page for the functions.

★ 提示2: 产品详细信息请参照承认书。  
Notes2: Product have a detail in the approval sheet.

★ 提示3: 产品规格变更不另行通知。  
Notes3: Specifications are subject to change without notice.

★ 提示4: 调速方式只能制作12V机型。  
Note4: Speed control mode only for 12V products.

# DC AXIAL FAN

## 50x50x20mm

### RS5020 Series



外框材质:环保防火PBT  
Frame:Thermoplastic PBT UL94-V0  
扇叶材质:环保防火PBT  
Impeller:Thermoplastic PBT UL94-V0  
轴承结构:双滚珠或长寿命含油结构  
Bearing system:2Ball or Long life sleeve  
单体风扇重量:32g  
Unit Weight:32g

#### 可选的功能参照列表 (Available Functions)

##### 1. 马达保护 (Motor protection)

RP	SS	AS	CL
<input type="checkbox"/>	<input type="checkbox"/>	<input type="checkbox"/>	<input type="checkbox"/>

##### 2. 信号输出 (Signal output)

FG	RD	RD	LD
<input type="checkbox"/>	<input type="checkbox"/>	<input type="checkbox"/>	<input type="checkbox"/>

##### 3. 调速方式 (Speed control mode)

PWM	TP	VC	RC	CS
<input type="checkbox"/>	<input type="checkbox"/>	<input type="checkbox"/>	<input type="checkbox"/>	<input type="checkbox"/>

DIMENSIONS DRAWING

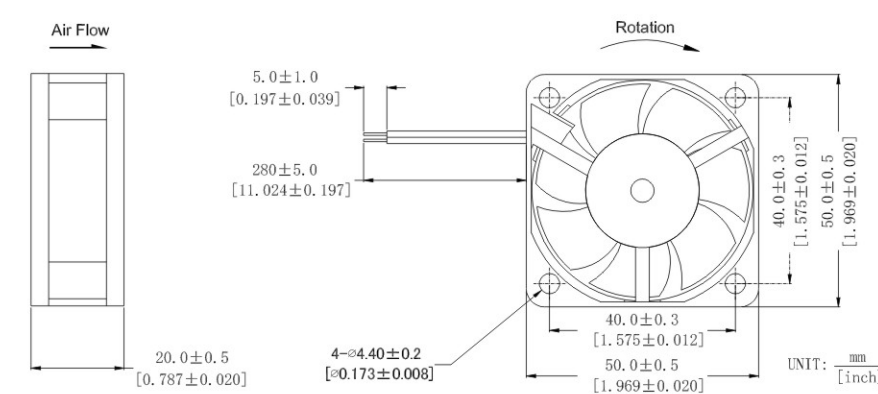

Fan Performance Curve

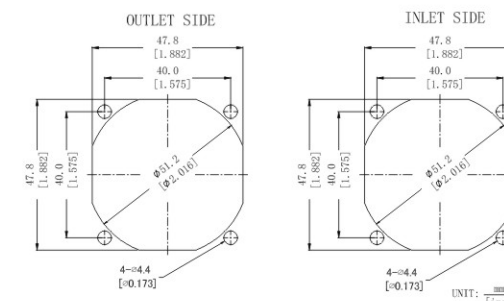
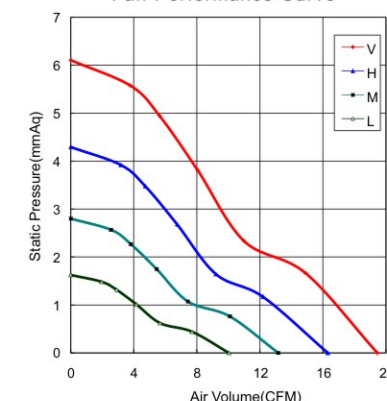

Part Number	Voltage(V)	Current(A)	Power(W)	Speed(RPM)	Air flow(Q)	Pressure(P)	Noise(dBA)
产品编号	电压范围	额定电流	功率	转速	(CFM)风量	m <sup>3</sup> /min	(mmAq)风压
RS5020x05L	5(4~6)	0.16	0.80	3200	10.04	0.28	1.63
RS5020x05M		0.32	1.60	4200	13.17	0.37	2.80
RS5020x12L		0.06	0.72	3200	10.04	0.28	1.63
RS5020x12M	12(7~14)	0.14	1.68	4200	13.17	0.37	2.80
RS5020x12H		0.18	2.16	5200	16.31	0.46	4.29
RS5020x12VH		0.22	2.64	6200	19.44	0.55	6.10
RS5020x24H	24(15~27)	0.09	2.16	5200	16.31	0.46	4.29
RS5020x24VH		0.11	2.64	6200	19.44	0.55	6.10

★ 如果您需要的转速或电压或功能不在这份清单上, 请与我们联系。  
If you want another rpm or voltage or functions which one is not in the list, please contact with our sales.

★ 提示1: 功能的具体信息参照产品目录前页篇章。  
Notes1: The catalog have detail information in the front page for the functions.

★ 提示2: 产品详细信息请参照承认书。  
Notes2: Product have a detail in the approval sheet.

★ 提示3: 产品规格变更不另行通知。  
Notes3: Specifications are subject to change without notice.

★ 提示4: 调速方式只能制作12V机型。  
Note4: Speed control mode only for 12V products.

# DC AXIAL FAN

## 50x50x25mm

### RS5025 Series



外框材质:环保防火PBT  
Frame:Thermoplastic PBT UL94-V0  
扇叶材质:环保防火PBT  
Impeller:Thermoplastic PBT UL94-V0  
轴承结构:双滚珠或长寿命含油结构  
Bearing system:2Ball or Long life sleeve  
单体风扇重量:24g  
Unit Weight:24g

DIMENSIONS DRAWING

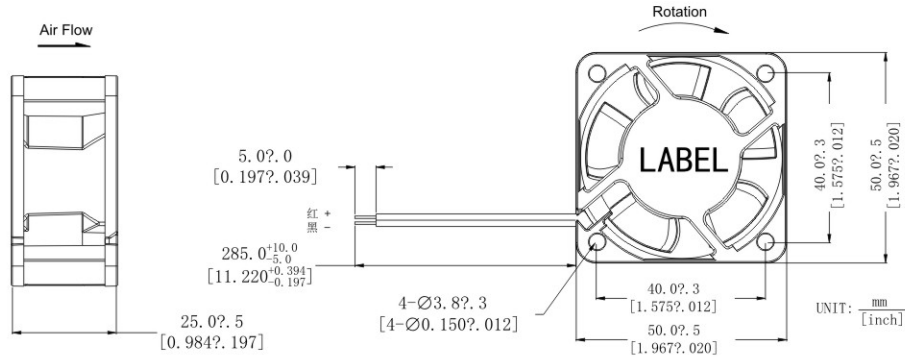

#### 可选的功能参照列表 (Available Functions)

1.马达保护(Motor protection)

RP	SS	AS	CL
●	●	●	●

2.信号输出(Signal output)

FG	RD	RD	LD
●	●	○	○

3.调速方式(Speed control mode)

PWM	TP	VC	RC	CS
●	○	○	○	●

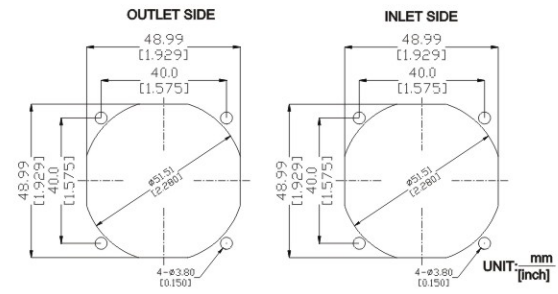
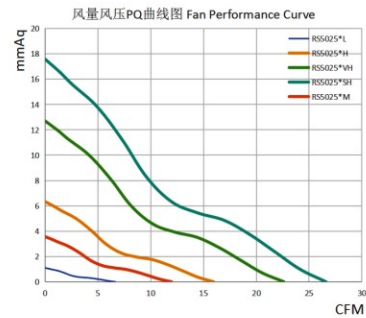

Part Number	Voltage(V)	Current(A)	Power(W)	Speed(RPM)	Air flow(Q)	Pressure(P)	Noise(dBA)
产品编号	电压范围	额定电流	功率	转速	(CFM)风量	(mmAq)风压	(In H <sub>2</sub> O) 噪音
RS5025(X)12L	12(7~14)	0.04	0.48	2500	6.65	1.10	18.5
RS5025(X)12M		0.08	0.96	4500	11.97	3.56	24.7
RS5025(X)12H		0.14	1.68	6000	15.96	6.33	32.93
RS5025(X)12VH		0.21	2.52	8500	22.61	12.70	37.04
RS5025(X)12SH		0.28	3.36	10000	26.60	17.58	41.5
RS5025(X)24L	24(15~27)	0.02	0.48	2500	6.65	1.10	18.5
RS5025(X)24M		0.04	0.96	4500	11.97	3.56	24.7
RS5025(X)24H		0.07	1.68	6000	15.96	6.33	32.93
RS5025(X)24VH		0.11	2.64	8500	22.61	12.70	37.04
RS5025(X)24SH		0.14	3.36	10000	26.60	17.58	41.5
RS5025(X)48L	48(35~57)	0.01	0.48	2500	6.65	1.10	18.5
RS5025(X)48M		0.02	0.96	4500	11.97	3.56	24.7
RS5025(X)48H		0.04	1.92	6000	15.96	6.33	32.93
RS5025(X)48VH		0.06	2.88	8500	22.61	12.70	37.04
RS5025(X)48SH		0.07	3.36	10000	26.60	17.58	41.5

- ★ 如果您需要的转速或电压或功能不在这份清单上, 请与我们联系。  
If you want another rpm or voltage or functions which one is not in the list, please contact with our sales.
- ★ 提示1:功能的具体信息参照产品目录前页篇章。  
Notes1:The catalog have detail information in the front page for the functions.
- ★ 提示2:产品详细信息请参照承认书。  
Notes2:Product have a detail in the approval sheet.
- ★ 提示3:产品规格变更不另行通知。  
Notes3:Specifications are subject to change without notice.
- ★ 提示4:调速方式只能制作12V机型。  
Note4:Speed control mode only for 12V products.

# DC AXIAL FAN

## 60x60x10mm

### RS6010 Series

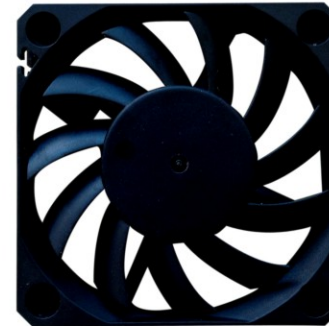

外框材质:环保防火PBT  
Frame:Thermoplastic PBT UL94-V0  
扇叶材质:环保防火PBT  
Impeller:Thermoplastic PBT UL94-V0  
轴承结构:双滚珠或长寿命含油结构  
Bearing system:2Ball or Long life sleeve  
单体风扇重量:26g  
Unit Weight:26g

DIMENSIONS DRAWING

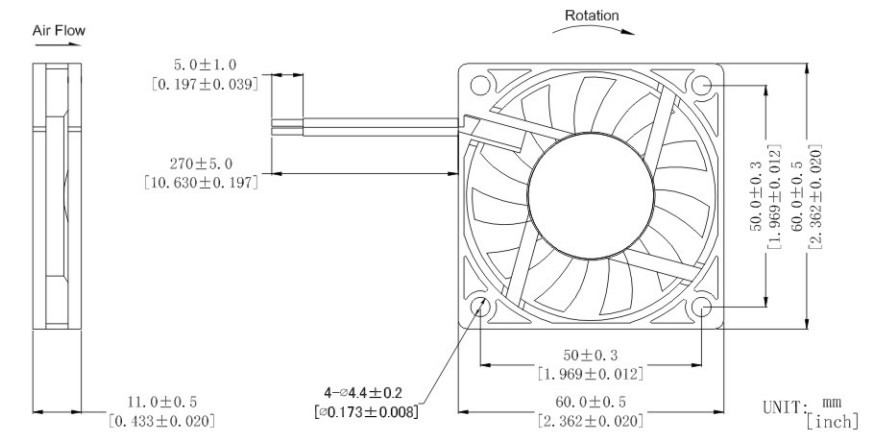

#### 可选的功能参照列表 (Available Functions)

1.马达保护(Motor protection)

RP	SS	AS	CL
●	○	●	○

2.信号输出(Signal output)

FG	RD	RD	LD
●	●	○	○

3.调速方式(Speed control mode)

PWM	TP	VC	RC	CS
●	○	○	○	○

Fan Performance Curve

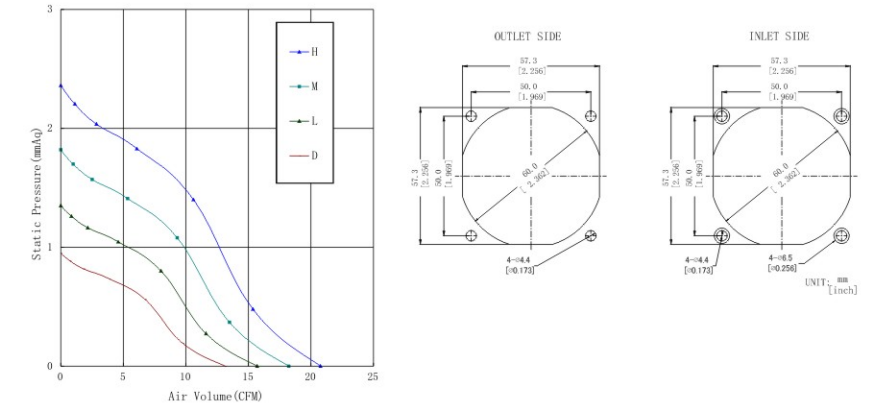

Part Number	Voltage(V)	Current(A)	Power(W)	Speed(RPM)	Air flow(Q)	Pressure(P)	Noise(dBA)
产品编号	电压范围	额定电流	功率	转速	(CFM)风量	(mmAq)风压	(In H <sub>2</sub> O) 噪音
RS6010x05L	5(4~6)	0.15	0.75	2500	13.17	0.37	21.6
RS6010x05M		0.27	1.35	3000	15.70	0.44	24.0
RS6010x05H		0.34	1.7	3500	18.23	0.52	26.7
RS6010x12L	12(7~14)	0.06	0.72	2500	13.17	0.37	21.6
RS6010x12M		0.11	1.32	3000	15.70	0.44	24.0
RS6010x12H		0.14	1.68	3500	18.23	0.52	26.7
RS6010x12VH	24(15~27)	0.18	2.16	4000	20.76	0.59	29.2
RS6010x24M		0.05	1.2	3000	15.31	0.43	24.0
RS6010x24H		0.07	1.68	3500	17.80	0.50	26.7
RS6010x24VH		0.09	2.16	4000	20.76	0.59	29.2

- ★ 如果您需要的转速或电压或功能不在这份清单上, 请与我们联系。  
If you want another rpm or voltage or functions which one is not in the list, please contact with our sales.
- ★ 提示1:功能的具体信息参照产品目录前页篇章。  
Notes1:The catalog have detail information in the front page for the functions.
- ★ 提示2:产品详细信息请参照承认书。  
Notes2:Product have a detail in the approval sheet.
- ★ 提示3:产品规格变更不另行通知。  
Notes3:Specifications are subject to change without notice.
- ★ 提示4:调速方式只能制作12V机型。  
Note4:Speed control mode only for 12V products.

## DC AXIAL FAN

### 60x60x15mm RS6015 Series



外框材质:环保防火PBT  
Frame:Thermoplastic PBT UL94-V0  
扇叶材质:环保防火PBT  
Impeller:Thermoplastic PBT UL94-V0  
轴承结构:双滚珠或长寿命含油结构  
Bearing system:2Ball or Long life sleeve  
单体风扇重量:28g  
Unit Weight:28g

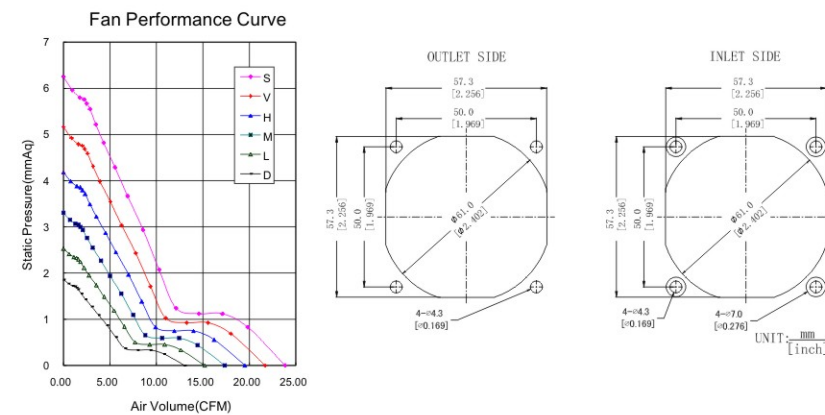
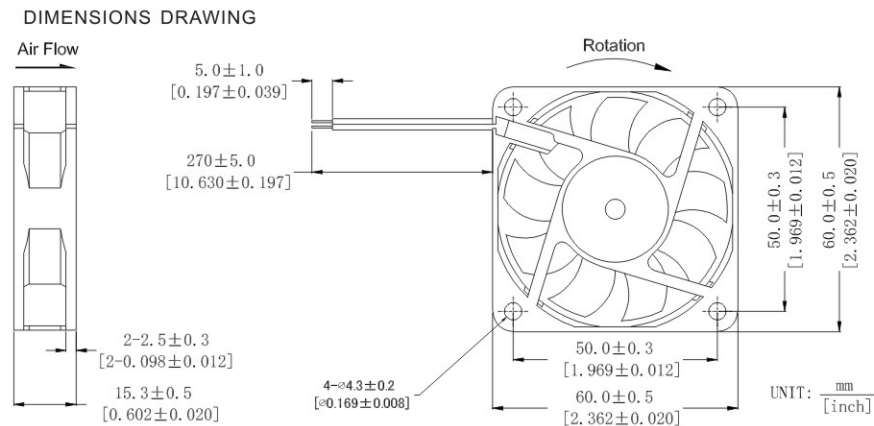

#### 可选的功能参照列表 (Available Functions)

##### 1. 马达保护(Motor protection)

RP	SS	AS	CL
●	○	●	○

##### 2. 信号输出(Signal output)

FG	RD	RD	LD
●	●	○	○

##### 3. 调速方式(Speed control mode)

PWM	TP	VC	RC	CS
●	○	○	○	○

Part Number	Voltage(V)	Current(A)	Power(W)	Speed(RPM)	Air flow(Q)	Pressure(P)	Noise(dBA)
产品编号	电压范围	额定电流	功率	转速	(CFM) 风量	m <sup>3</sup> /min (mmAq)风压 (In H <sub>2</sub> O)	噪音
RS6015x05D	5(4~6)	0.29	1.45	3000	13.01	0.37	29.2
RS6015x05L		0.36	1.8	3500	15.18	0.43	30.0
RS6015x05M		0.46	2.3	4000	17.35	0.49	31.5
RS6015x12D	12(7~14)	0.12	1.44	3000	13.01	0.37	29.2
RS6015x12L		0.15	1.8	3500	15.18	0.43	30.0
RS6015x12M		0.19	2.28	4000	17.35	0.49	31.5
RS6015x12H		0.21	2.52	4500	19.52	0.55	34.5
RS6015x12VH		0.23	2.76	5000	21.69	0.61	35.6
RS6015x12SH		0.28	3.36	5500	23.86	0.68	38.0
RS6015x24L	24(15~27)	0.075	1.8	3500	15.18	0.43	30.0
RS6015x24M		0.1	2.4	4000	17.35	0.49	31.5
RS6015x24H		0.11	2.64	4500	19.52	0.55	34.5
RS6015x24VH		0.12	2.88	5000	21.69	0.61	35.6
RS6015x24SH		0.14	3.36	5500	23.86	0.68	38.0

★ 如果您需要的转速或电压或功能不在这份清单上, 请与我们联系。  
If you want another rpm or voltage or functions which one is not in the list, please contact with our sales.

★ 提示1: 功能的具体信息参照产品目录前页篇章。  
Notes1: The catalog have detail information in the front page for the functions.

★ 提示2: 产品详细信息请参照承认书。  
Notes2: Product have a detail in the approval sheet.

★ 提示3: 产品规格变更不另行通知。  
Notes3: Specifications are subject to change without notice.

★ 提示4: 调速方式只能制作12V机型。  
Note4: Speed control mode only for 12V products.

## DC AXIAL FAN

### 60x60x20mm RS6020 Series



外框材质:环保防火PBT  
Frame:Thermoplastic PBT UL94-V0  
扇叶材质:环保防火PBT  
Impeller:Thermoplastic PBT UL94-V0  
轴承结构:双滚珠或长寿命含油结构  
Bearing system:2Ball or Long life sleeve  
单体风扇重量:50g  
Unit Weight:50g

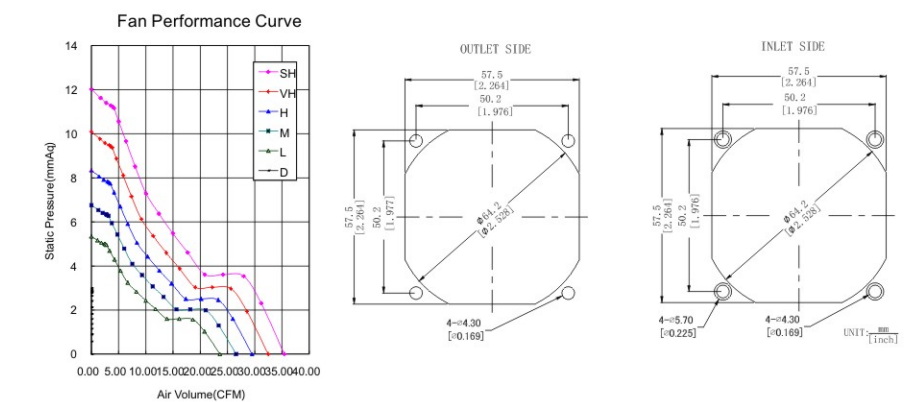
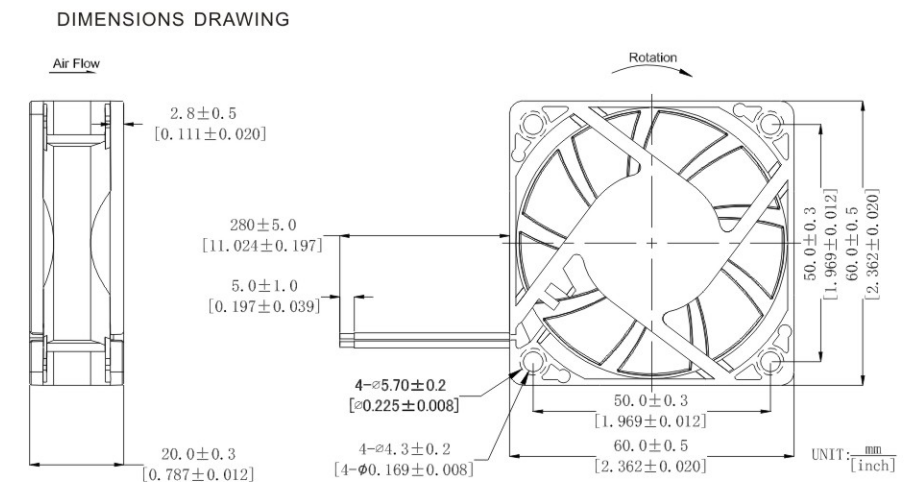

#### 可选的功能参照列表 (Available Functions)

##### 1. 马达保护(Motor protection)

RP	SS	AS	CL
●	●	●	●

##### 2. 信号输出(Signal output)

FG	RD	RD	LD
●	●	○	○

##### 3. 调速方式(Speed control mode)

PWM	TP	VC	RC	CS
●	●	●	●	●

Part Number	Voltage(V)	Current(A)	Power(W)	Speed(RPM)	Air flow(Q)	Pressure(P)	Noise(dBA)
产品编号	电压范围	额定电流	功率	转速	(CFM) 风量	m <sup>3</sup> /min (mmAq)风压 (In H <sub>2</sub> O)	噪音
RS6020x05D	5(4~6)	0.14	1.68	3000	17.71	0.50	28.7
RS6020x05L		0.30	3.6	4000	23.61	0.67	33.9
RS6020x12D	12(7~14)	0.06	0.72	3000	17.71	0.50	28.7
RS6020x12L		0.13	1.56	4000	23.61	0.67	33.9
RS6020x12M		0.15	1.8	4500	26.56	0.75	38.1
RS6020x12H		0.22	2.64	5000	29.51	0.84	41.2
RS6020x12VH		0.29	3.48	5500	32.46	0.92	43.7
RS6020x24L		24(15~27)	0.06	0.72	4000	23.61	0.67
RS6020x24M	0.08		1.92	4500	26.56	0.75	38.1
RS6020x24H	0.11		2.64	5000	29.51	0.84	41.2
RS6020x24VH	0.15		3.6	5500	32.46	0.92	43.7
RS6020x24SH	0.21		5.04	6000	35.41	1.00	45.5

★ 如果您需要的转速或电压或功能不在这份清单上, 请与我们联系。  
If you want another rpm or voltage or functions which one is not in the list, please contact with our sales.

★ 提示1: 功能的具体信息参照产品目录前页篇章。  
Notes1: The catalog have detail information in the front page for the functions.

★ 提示2: 产品详细信息请参照承认书。  
Notes2: Product have a detail in the approval sheet.

★ 提示3: 产品规格变更不另行通知。  
Notes3: Specifications are subject to change without notice.

★ 提示4: 调速方式只能制作12V机型。  
Note4: Speed control mode only for 12V products.

## DC AXIAL FAN

### 60x60x25mm

#### RS6025 Series



外框材质:环保防火PBT  
Frame:Thermoplastic PBT UL94-V0  
扇叶材质:环保防火PBT  
Impeller:Thermoplastic PBT UL94-V0  
轴承结构:双滚珠或长寿命含油结构  
Bearing system:2Ball or Long life sleeve  
单体风扇重量:58g  
Unit Weight:58g

DIMENSIONS DRAWING

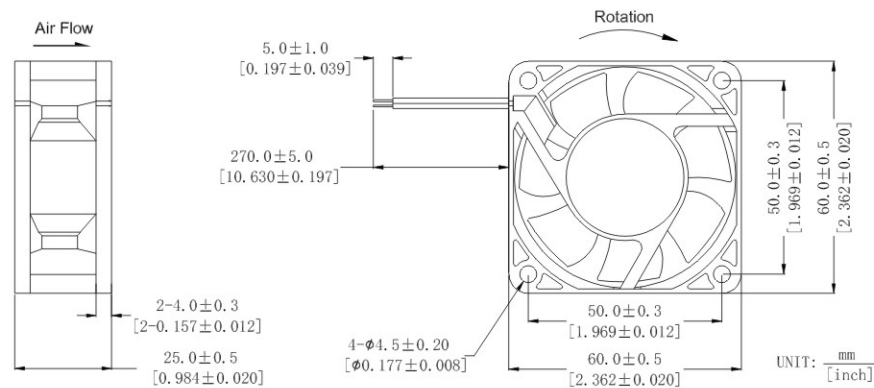

Fan Performance Curve

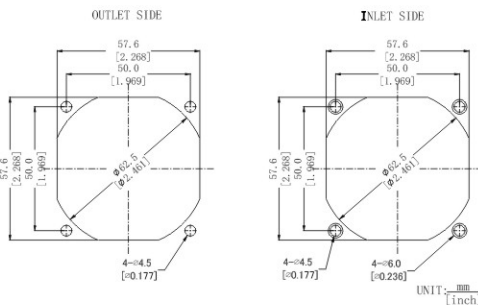
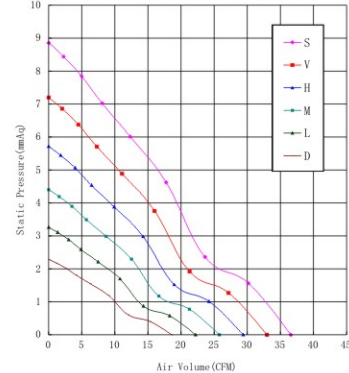

#### 可选的功能参照列表 (Available Functions)

##### 1.马达保护(Motor protection)

RP	SS	AS	CL
●	●	●	●

##### 2.信号输出(Signal output)

FG	RD	RD	LD
●	●	●	●

##### 3.调速方式(Speed control mode)

PWM	TP	VC	RC	CS
●	●	●	●	●

Part Number	Voltage(V)	Current(A)	Power(W)	Speed(RPM)	Air flow(Q)	Pressure(P)	Noise(dBA)	
产品编号	电压范围	额定电流	功率	转速	(CFM) 风量	m <sup>3</sup> /min (mmAq)风压 (In H <sub>2</sub> O)	噪音	
RS6025x12D	12(7~14)	0.12	1.44	3000	18.59	0.53 2.29	27.2	
RS6025x12L		0.18	2.16	3600	22.19	0.63 3.26	30.5	
RS6025x12M		0.22	2.64	4200	25.79	0.73 4.40	35.7	
RS6025x12H		0.28	3.36	4800	29.39	0.83 5.72	39.4	
RS6025x12VH		0.34	4.08	5400	32.99	0.93 7.20	42.0	
RS6025x12SH		0.32	3.84	6000	36.58	1.04 8.86	44.8	
RS6025x24D		24(15~27)	0.06	1.44	3000	18.59	0.53 2.29	27.2
RS6025x24L	0.09		2.16	3600	22.19	0.63 3.26	30.5	
RS6025x24M	0.11		2.64	4200	25.79	0.73 4.40	35.7	
RS6025x24H	0.14		3.36	4800	29.39	0.83 5.72	39.4	
RS6025x24VH	0.17		4.08	5400	32.99	0.93 7.20	42.0	
RS6025x24SH	0.16		3.84	6000	36.58	1.04 8.86	44.8	
RS6025x48M	48(35~57)		0.05	2.4	4200	25.79	0.73 4.40	35.7
RS6025x48H		0.07	3.36	4800	29.39	0.83 5.72	39.4	
RS6025x48VH		0.08	4.08	5400	32.99	0.93 7.20	42.0	
RS6025x48SH		0.08	3.84	6000	36.58	1.04 8.86	44.8	
RD6025x12D		12(7~14)	0.09	1.08	3500	17.07	0.48 3.55	30.8
RD6025x12L	0.15		1.8	4500	21.94	0.62 5.87	35.2	
RD6025x12M	0.21		2.52	5500	26.82	0.76 8.77	39.5	
RD6025x12H	0.32		3.84	6500	31.70	0.90 12.25	46.3	
RD6025x12VH	0.31		3.72	7500	36.58	1.04 16.31	49.5	
RD6025x12SH	0.36		4.32	8000	39.02	1.10 18.56	50.9	
RD6025x24D	24(15~27)		0.05	1.2	3500	17.07	0.48 3.55	30.8
RD6025x24L			0.075	1.8	4500	21.94	0.62 5.87	35.2
RD6025x24M			0.11	2.64	5500	26.82	0.76 8.77	39.5
RD6025x24H			0.14	3.36	6500	31.70	0.90 12.25	46.3
RD6025x24VH			0.16	3.84	7500	36.58	1.04 16.31	49.5
RD6025x24SH			0.18	4.32	8000	39.02	1.10 18.56	50.9
RD6025x48D	48(35~57)	0.025	1.2	3500	17.07	0.48 3.55	30.8	
RD6025x48L		0.038	1.824	4500	21.94	0.62 5.87	35.2	
RD6025x48M		0.055	2.64	5500	26.82	0.76 8.77	39.5	
RD6025x48H		0.08	3.84	6500	31.70	0.90 12.25	46.3	
RD6025x48VH		0.08	3.84	7500	36.58	1.04 16.31	49.5	
RD6025x48SH	0.09	4.32	8000	39.02	1.10 18.56	50.9		

★ 如果您需要的转速或电压或功能不在这份清单上, 请与我们联系。  
If you want another rpm or voltage or functions which one is not in the list, please contact with our sales.

★ 提示1:功能的具体信息参照产品目录前页篇章。  
Notes 1:The catalog have detail information in the front page for the functions.

★ 提示2:产品详细信息请参照承认书。  
Notes 2:Product have a detail in the approval sheet.

★ 提示3:产品规格变更不另行通知。  
Notes 3:Specifications are subject to change without notice.

## DC AXIAL FAN

### 60x60x25mm

#### RD6025 Series



外框材质:环保防火PBT  
Frame:Thermoplastic PBT UL94-V0  
扇叶材质:环保防火PBT  
Impeller:Thermoplastic PBT UL94-V0  
轴承结构:双滚珠或长寿命含油结构  
Bearing system:2Ball or Long life sleeve  
单体风扇重量:55g  
Unit Weight:55g

#### 可选的功能参照列表 (Available Functions)

##### 1.马达保护(Motor protection)

RP	SS	AS	CL
●	●	●	●

##### 2.信号输出(Signal output)

FG	RD	RD	LD
●	●	●	●

##### 3.调速方式(Speed control mode)

PWM	TP	VC	RC	CS
●	●	●	●	●

DIMENSIONS DRAWING

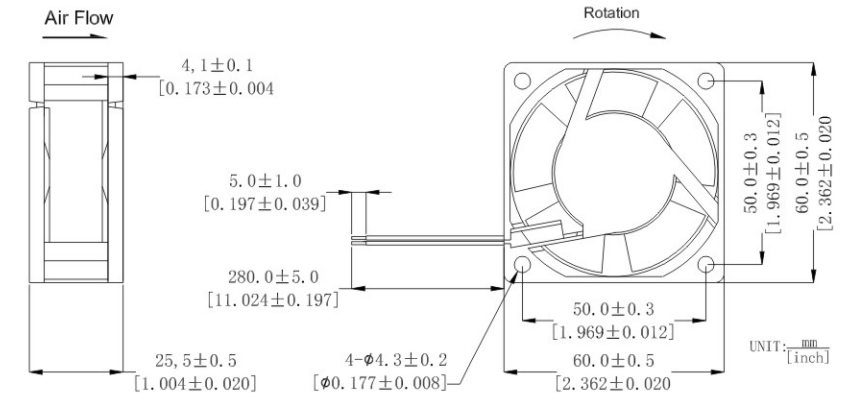

Fan Performance Curve

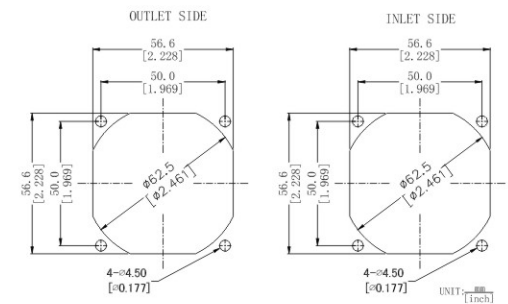
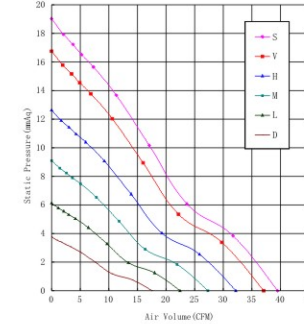

Part Number	Voltage(V)	Current(A)	Power(W)	Speed(RPM)	Air flow(Q)	Pressure(P)	Noise(dBA)	
产品编号	电压范围	额定电流	功率	转速	(CFM) 风量	(mmAq)风压 (In H <sub>2</sub> O)	噪音	
RD6025x12D	12(7~14)	0.09	1.08	3500	17.07	0.48 3.55	30.8	
RD6025x12L		0.15	1.8	4500	21.94	0.62 5.87	35.2	
RD6025x12M		0.21	2.52	5500	26.82	0.76 8.77	39.5	
RD6025x12H		0.32	3.84	6500	31.70	0.90 12.25	46.3	
RD6025x12VH		0.31	3.72	7500	36.58	1.04 16.31	49.5	
RD6025x12SH		0.36	4.32	8000	39.02	1.10 18.56	50.9	
RD6025x24D		24(15~27)	0.05	1.2	3500	17.07	0.48 3.55	30.8
RD6025x24L			0.075	1.8	4500	21.94	0.62 5.87	35.2
RD6025x24M			0.11	2.64	5500	26.82	0.76 8.77	39.5
RD6025x24H			0.14	3.36	6500	31.70	0.90 12.25	46.3
RD6025x24VH			0.16	3.84	7500	36.58	1.04 16.31	49.5
RD6025x24SH			0.18	4.32	8000	39.02	1.10 18.56	50.9
RD6025x48D	48(35~57)	0.025	1.2	3500	17.07	0.48 3.55	30.8	
RD6025x48L		0.038	1.824	4500	21.94	0.62 5.87	35.2	
RD6025x48M		0.055	2.64	5500	26.82	0.76 8.77	39.5	
RD6025x48H		0.08	3.84	6500	31.70	0.90 12.25	46.3	
RD6025x48VH		0.08	3.84	7500	36.58	1.04 16.31	49.5	
RD6025x48SH	0.09	4.32	8000	39.02	1.10 18.56	50.9		

★ 如果您需要的转速或电压或功能不在这份清单上, 请与我们联系。  
If you want another rpm or voltage or functions which one is not in the list, please contact with our sales.

★ 提示1:功能的具体信息参照产品目录前页篇章。  
Notes 1:The catalog have detail information in the front page for the functions.

★ 提示2:产品详细信息请参照承认书。  
Notes 2:Product have a detail in the approval sheet.

★ 提示3:产品规格变更不另行通知。  
Notes 3:Specifications are subject to change without notice.

## DC AXIAL FAN

### 60x60x25mm RD6025-B Series



外框材质:环保防火PBT  
Frame:Thermoplastic PBT UL94-V0  
扇叶材质:环保防火PBT  
Impeller:Thermoplastic PBT UL94-V0  
轴承结构:双滚珠或长寿命含油结构  
Bearing system:2Ball or Long life sleeve  
单体风扇重量:58g  
Unit Weight:58g

#### 可选的功能参照列表 (Available Functions)

##### 1.马达保护(Motor protection)

RP	SS	AS	CL
●	●	●	●

##### 2.信号输出(Signal output)

FG	RD	RD	LD
●	●	●	●

##### 3.调速方式(Speed control mode)

PWM	TP	VC	RC	CS
●	●	●	●	●

DIMENSIONS DRAWING

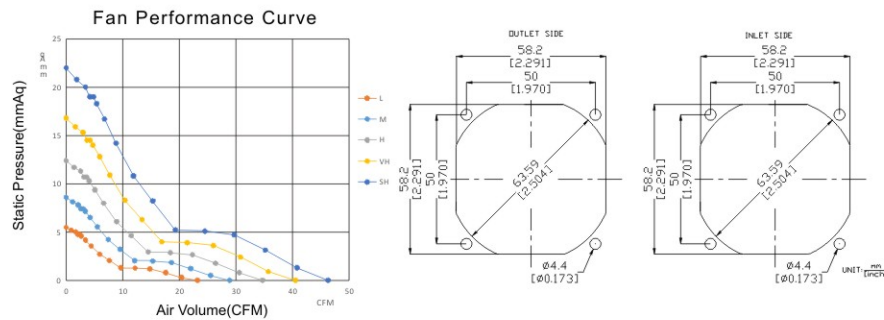
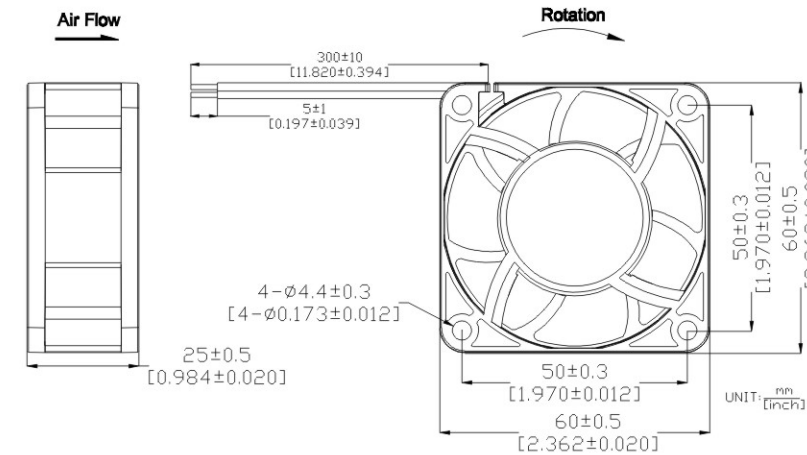

Part Number	Voltage(V)	Current(A)	Power(W)	Speed(RPM)	Air flow(Q)	Pressure(P)	Noise(dBA)		
产品编号	电压范围	额定电流	功率	转速	(CFM)风量	m <sup>3</sup> /min	(mmAq)风压	(In H <sub>2</sub> O)	噪音
RD6025x12L	12(7~14)	0.08	0.95	4000	23.16	0.66	5.49	0.22	32.53
RD6025x12M		0.12	1.51	5000	28.94	0.82	8.58	0.34	36.27
RD6025x12H		0.18	2.25	6000	34.73	0.98	12.36	0.49	40.74
RD6025x12VH	24(15~27)	0.27	3.28	7000	40.52	1.15	16.82	0.66	46.46
RD6025x24L		0.04	0.95	4000	23.16	0.66	5.49	0.22	32.53
RD6025x24M		0.06	1.51	5000	28.94	0.82	8.58	0.34	36.27
RD6025x24H	48(35~57)	0.09	2.25	6000	34.73	0.98	12.36	0.49	40.74
RD6025x24VH		0.13	3.28	7000	40.52	1.15	16.82	0.66	46.46
RD6025x24SH		0.20	4.74	8000	46.31	1.31	21.97	0.86	50.31
RD6025x48L	48(35~57)	0.02	0.95	4000	23.16	0.66	5.49	0.22	32.53
RD6025x48M		0.03	1.51	5000	28.94	0.82	8.58	0.34	36.27
RD6025x48H		0.05	2.25	6000	34.73	0.98	12.36	0.49	40.74
RD6025x48VH		0.07	3.28	7000	40.52	1.15	16.82	0.66	46.46
RD6025x48SH		0.10	4.74	8000	46.31	1.31	21.97	0.86	50.31

★ 如果您需要的转速或电压或功能不在这份清单上, 请与我们联系。  
If you want another rpm or voltage or functions which one is not in the list, please contact with our sales.

★ 提示1:功能的具体信息参照产品目录前页篇章。  
Notes1:The catalog have detail information in the front page for the functions.

★ 提示2:产品详细信息请参照承认书。  
Notes2:Product have a detail in the approval sheet.

★ 提示3:产品规格变更不另行通知。  
Notes3:Specifications are subject to change without notice.

★ 提示4:调速方式只能制作12V机型。  
Note4:Speed control mode only for 12V products.

## DC AXIAL FAN

### 60x60x38mm RD6038 Series



外框材质:环保防火PBT  
Frame:Thermoplastic PBT UL94-V0  
扇叶材质:环保防火PBT  
Impeller:Thermoplastic PBT UL94-V0  
轴承结构:双滚珠或长寿命含油结构  
Bearing system:2Ball or Long life sleeve  
单体风扇重量:106g  
Unit Weight:106g

#### 可选的功能参照列表 (Available Functions)

##### 1.马达保护(Motor protection)

RP	SS	AS	CL
●	●	●	●

##### 2.信号输出(Signal output)

FG	RD	RD	LD
●	●	●	●

##### 3.调速方式(Speed control mode)

PWM	TP	VC	RC	CS
●	●	●	●	●

DIMENSIONS DRAWING

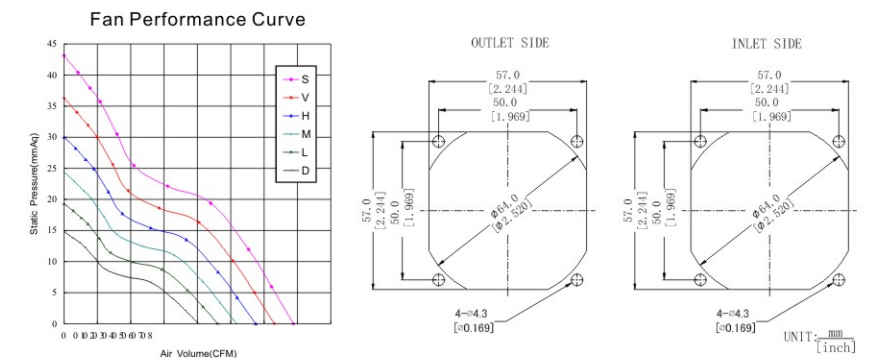
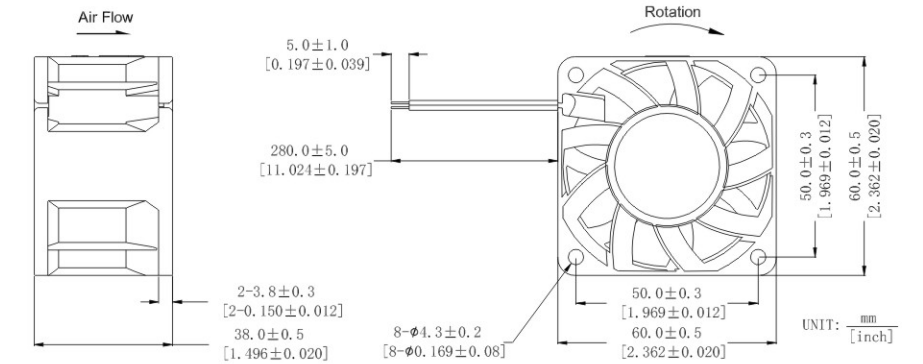

Part Number	Voltage(V)	Current(A)	Power(W)	Speed(RPM)	Air flow(Q)	Pressure(P)	Noise(dBA)		
产品编号	电压范围	额定电流	功率	转速	(CFM)风量	m <sup>3</sup> /min	(Mmaq)风压	(In H <sub>2</sub> O)	噪音
RD6038x12D	12(7~14)	0.40	4.8	7000	40.40	1.14	14.80	0.58	53.8
RD6038x12L		0.60	7.2	8000	46.10	1.30	19.30	0.76	56.7
RD6038x12M		0.65	7.8	9000	51.80	1.47	24.40	0.96	58.5
RD6038x12H	24(15~27)	1.00	12	10000	57.50	1.63	30.00	1.18	61.0
RD6038x12VH		1.30	15.6	11000	63.10	1.79	36.30	1.43	63.8
RD6038x24D		0.20	4.8	7000	40.40	1.14	14.80	0.58	53.8
RD6038x24L	24(15~27)	0.30	7.2	8000	46.10	1.30	19.30	0.76	56.7
RD6038x24M		0.32	7.68	9000	51.80	1.47	24.40	0.96	58.5
RD6038x24H		0.50	12	10000	57.50	1.63	30.00	1.18	61.0
RD6038x24VH		0.65	15.6	11000	63.10	1.79	36.30	1.43	63.8
RD6038x24SH		0.85	20.4	12000	68.80	1.95	43.10	1.70	68.2

★ 如果您需要的转速或电压或功能不在这份清单上, 请与我们联系。  
If you want another rpm or voltage or functions which one is not in the list, please contact with our sales.

★ 提示1:功能的具体信息参照产品目录前页篇章。  
Notes1:The catalog have detail information in the front page for the functions.

★ 提示2:产品详细信息请参照承认书。  
Notes2:Product have a detail in the approval sheet.

★ 提示3:产品规格变更不另行通知。  
Notes3:Specifications are subject to change without notice.

# DC AXIAL FAN

## 60x60x38mm RD6038 A Series



DIMENSIONS DRAWING

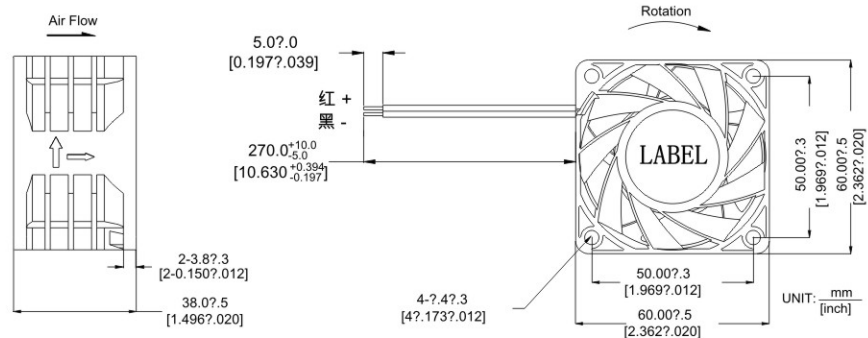

外框材质:环保防火PBT  
Frame: Thermoplastic PBT UL94-V0  
扇叶材质:环保防火PBT  
Impeller: Thermoplastic PBT UL94-V0  
轴承结构:双滚珠  
Bearing system: 2Ball  
单体风扇重量:113g  
Unit Weight: 113g

可选的功能参照列表  
(Available Functions)

1. 马达保护 (Motor protection)

RP	SS	AS	CL
●	●	●	●

2. 信号输出 (Signal output)

FG	RD	RD	LD
●	●	●	●

3. 调速方式 (Speed control mode)

PWM	TP	VC	RC	CS
●	●	●	●	●

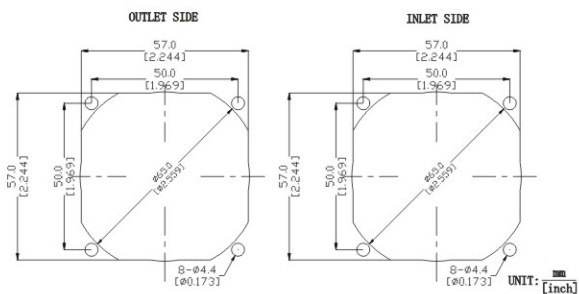
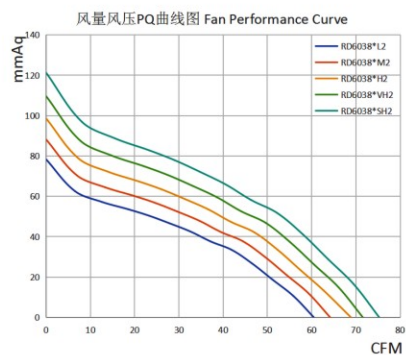

Part Number	Voltage(V)	Current(A)	Power(W)	Speed(RPM)	Air flow(Q)	Pressure(P)	Noise(dBA)
产品编号	电压范围	额定电流	功率	转速	(CFM) 风量	m <sup>3</sup> /min (mmAq)风压 (In H <sub>2</sub> O)	噪音
RD6038B12L2	12(7~14)	1.10	13.20	13100	60.50	1.72 78.30 3.08	59.50
RD6038B12M2		1.29	15.48	13900	64.19	1.82 88.16 3.47	62.48
RD6038B12H2		1.58	18.96	14700	68.89	1.95 98.59 3.88	63.73
RD6038B12VH2		1.86	22.32	15500	71.58	2.03 109.62 4.32	65.00
RD6038B12SH2		2.17	26.04	16300	75.28	2.14 121.23 4.77	66.30
RD6038B24L2	24(15~27)	0.55	13.20	13100	60.50	1.72 78.30 3.08	59.50
RD6038B24M2		0.65	15.60	13900	64.19	1.82 88.16 3.47	62.48
RD6038B24H2		0.79	18.96	14700	68.89	1.95 98.59 3.88	63.73
RD6038B24VH2		0.93	22.32	15500	71.58	2.03 109.62 4.32	65.00
RD6038B24SH2		1.09	26.16	16300	75.28	2.14 121.23 4.77	66.30
RD6038B48L2	48(35~57)	0.28	13.44	13100	60.50	1.72 78.30 3.08	59.50
RD6038B48M2		0.33	15.84	13900	64.19	1.82 88.16 3.47	62.48
RD6038B48H2		0.40	19.20	14700	68.89	1.95 98.59 3.88	63.73
RD6038B48VH2		0.47	22.56	15500	71.58	2.03 109.62 4.32	65.00
RD6038B48SH2		0.55	26.40	16300	75.28	2.14 121.23 4.77	66.30

★ 如果您需要的转速或电压或功能不在这份清单上, 请与我们联系。  
If you want another rpm or voltage or functions which one is not in the list, please contact with our sales.

★ 提示1: 功能的具体信息参照产品目录前页篇章。  
Notes 1: The catalog have detail information in the front page for the functions.

★ 提示2: 产品详细信息请参照承认书。  
Notes 2: Product have a detail in the approval sheet.

★ 提示3: 产品规格变更不另行通知。  
Notes 3: Specifications are subject to change without notice.

# DC AXIAL FAN

## 70x70x10mm RS7010 Series



DIMENSIONS DRAWING

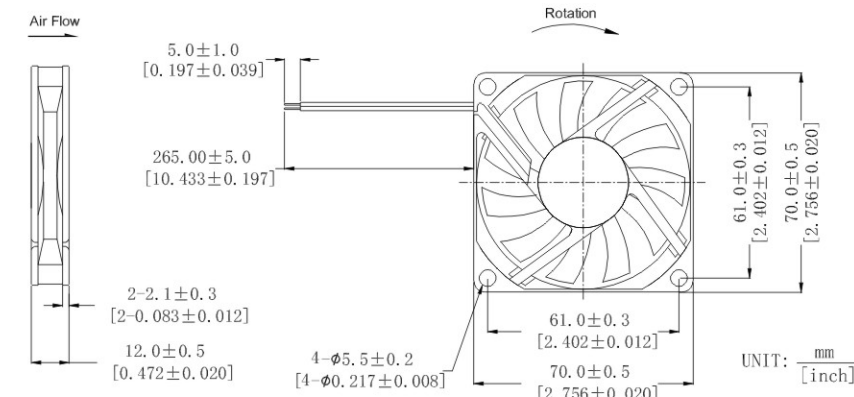

外框材质:环保防火PBT  
Frame: Thermoplastic PBT UL94-V0  
扇叶材质:环保防火PBT  
Impeller: Thermoplastic PBT UL94-V0  
轴承结构:双滚珠或长寿命含油结构  
Bearing system: 2Ball or Long life sleeve  
单体风扇重量:42g  
Unit Weight: 42g

可选的功能参照列表  
(Available Functions)

1. 马达保护 (Motor protection)

RP	SS	AS	CL
●	●	●	●

2. 信号输出 (Signal output)

FG	RD	RD	LD
●	●	●	●

3. 调速方式 (Speed control mode)

PWM	TP	VC	RC	CS
●	●	●	●	●

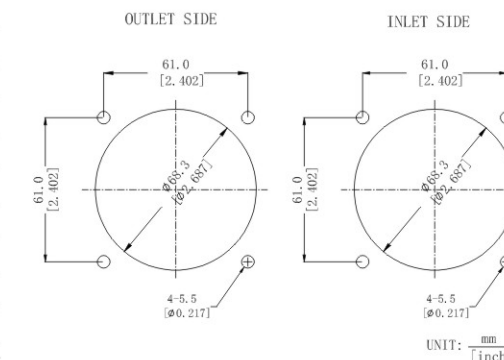
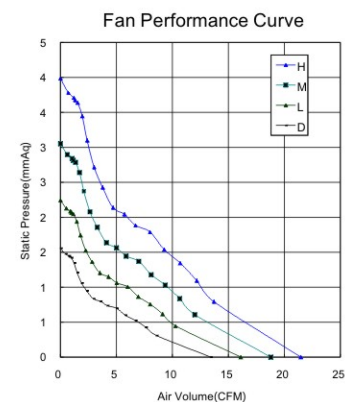

Part Number	Voltage(V)	Current(A)	Power(W)	Speed(RPM)	Air flow(Q)	Pressure(P)	Noise(dBA)
产品编号	电压范围	额定电流	功率	转速	(CFM) 风量	m <sup>3</sup> /min (mmAq)风压 (In H <sub>2</sub> O)	噪音
RS7010x05D	5(4~6)	0.15	0.75	2500	13.42	0.38 1.56	24.4
RS7010x05L		0.24	1.20	3000	16.11	0.46 2.24	29.9
RS7010x12D	12(7~14)	0.06	0.72	2500	13.42	0.38 1.56	24.4
RS7010x12L		0.10	1.20	3000	16.11	0.46 2.24	29.9
RS7010x12M		0.16	1.92	3500	18.79	0.53 3.05	33.0
RS7010x12H	24(15~27)	0.24	2.88	4000	21.48	0.61 3.99	36.2
RS7010x24L		0.05	1.20	3000	16.11	0.46 2.24	29.9
RS7010x24M		0.08	1.92	3500	18.79	0.53 3.05	33.0
RS7010x24H		0.14	3.36	4000	21.48	0.61 3.99	36.2

★ 如果您需要的转速或电压或功能不在这份清单上, 请与我们联系。  
If you want another rpm or voltage or functions which one is not in the list, please contact with our sales.

★ 提示1: 功能的具体信息参照产品目录前页篇章。  
Notes 1: The catalog have detail information in the front page for the functions.

★ 提示2: 产品详细信息请参照承认书。  
Notes 2: Product have a detail in the approval sheet.

★ 提示3: 产品规格变更不另行通知。  
Notes 3: Specifications are subject to change without notice.

### 70x70x15mm RS7015 Series



外框材质:环保防火PBT  
Frame:Thermoplastic PBT UL94-V0  
扇叶材质:环保防火PBT  
Impeller:Thermoplastic PBT UL94-V0  
轴承结构:双滚珠或长寿命含油结构  
Bearing system:2Ball or Long life sleeve  
单体风扇重量:42g  
Unit Weight:42g

#### 可选的功能参照列表 (Available Functions)

1.马达保护(Motor protection)

RP	SS	AS	CL
●	●	●	●

2.信号输出(Signal output)

FG	RD	RD	LD
●	●	●	●

3.调速方式(Speed control mode)

PWM	TP	VC	RC	CS
●	●	●	●	●

DIMENSIONS DRAWING

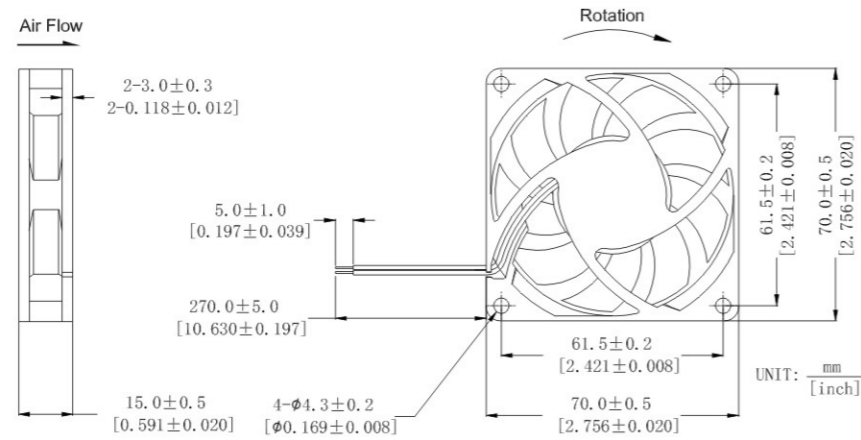

Fan Performance Curve

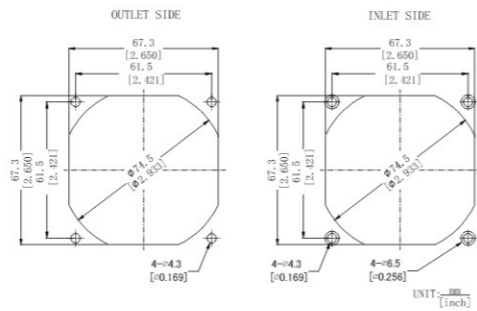
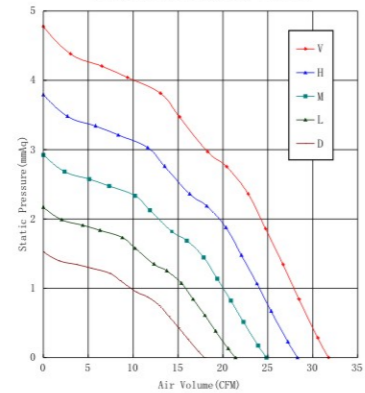

Part Number	Voltage(V)	Current(A)	Power(W)	Speed(RPM)	Air flow(Q)	Pressure(P)	Noise(dBA)
产品编号	电压范围	额定电流	功率	转速	(CFM) 风量	m <sup>3</sup> /min (mmAq)风压 (In H <sub>2</sub> O)	噪音
RS7015x05D	5(4~6)	0.22	1.1	2500	17.90	1.50	28.6
RS7015x05L		0.28	1.4	3000	21.40	2.20	30.4
RS7015x05M		0.46	2.3	3500	24.90	2.90	32.0
RS7015x12D	12(7~14)	0.09	1.08	2500	17.90	1.50	28.6
RS7015x12L		0.12	1.44	3000	21.40	2.20	30.4
RS7015x12M		0.2	2.4	3500	24.90	2.90	32.0
RS7015x12H	24(15~27)	0.24	2.88	4000	28.30	3.80	35.6
RS7015x12VH		0.26	3.12	4500	31.80	4.80	38.3
RS7015x24L		0.06	1.44	3000	21.40	2.20	30.4
RS7015x24M	24(15~27)	0.1	2.4	3500	24.90	2.90	32.0
RS7015x24H		0.12	2.88	4000	28.30	3.80	35.6
RS7015x24VH		0.13	3.12	4500	31.80	4.80	38.3

★ 如果您需要的转速或电压或功能不在这份清单上, 请与我们联系。  
If you want another rpm or voltage or functions which one is not in the list, please contact with our sales.

★ 提示1:功能的具体信息参照产品目录前页篇章。  
Notes1:The catalog have detail information in the front page for the functions.

★ 提示2:产品详细信息请参照承认书。  
Notes2:Product have a detail in the approval sheet.

★ 提示3:产品规格变更不另行通知。  
Notes3:Specifications are subject to change without notice.

### 70x70x25mm RS7025 Series



外框材质:环保防火PBT  
Frame:Thermoplastic PBT UL94-V0  
扇叶材质:环保防火PBT  
Impeller:Thermoplastic PBT UL94-V0  
轴承结构:双滚珠或长寿命含油结构  
Bearing system:2Ball or Long life sleeve  
单体风扇重量:78g  
Unit Weight:78g

#### 可选的功能参照列表 (Available Functions)

1.马达保护(Motor protection)

RP	SS	AS	CL
●	●	●	●

2.信号输出(Signal output)

FG	RD	RD	LD
●	●	●	●

3.调速方式(Speed control mode)

PWM	TP	VC	RC	CS
●	●	●	●	●

DIMENSIONS DRAWING

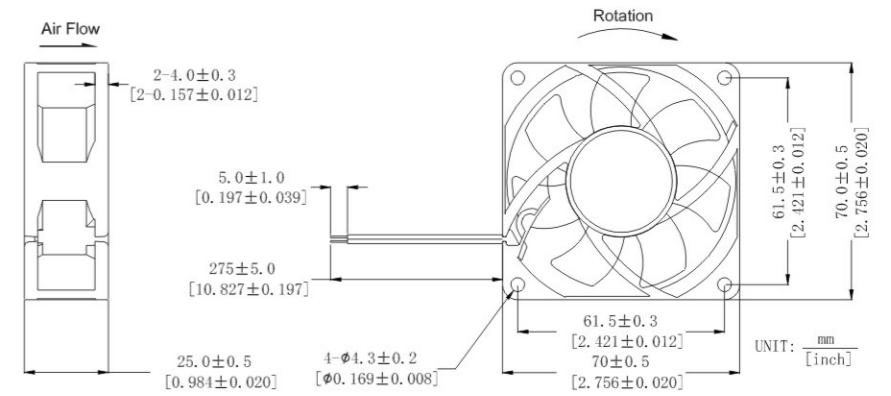

Fan Performance Curve

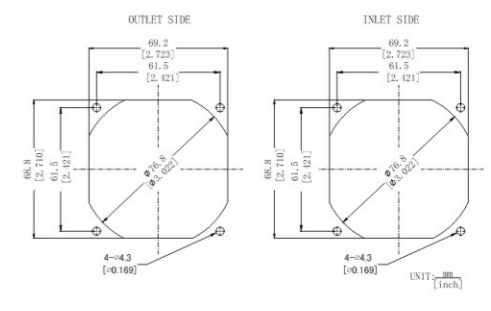
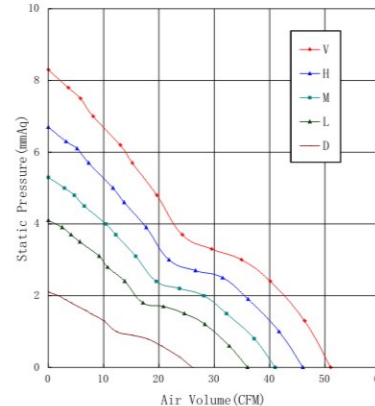

Part Number	Voltage(V)	Current(A)	Power(W)	Speed(RPM)	Air flow(Q)	Pressure(P)	Noise(dBA)
产品编号	电压范围	额定电流	功率	转速	(CFM) 风量	m <sup>3</sup> /min (mmAq)风压 (In H <sub>2</sub> O)	噪音
RS7025x12D	12(7~14)	0.10	1.2	2500	26.00	2.10	27.4
RS7025x12L		0.28	3.36	3500	36.00	4.10	35.5
RS7025x12M		0.31	3.72	4000	41.00	5.30	39.0
RS7025x12H	24(15~27)	0.36	4.32	4500	46.00	6.70	41.6
RS7025x24L		0.14	3.36	3500	36.00	4.10	35.5
RS7025x24M		0.16	3.84	4000	41.00	5.30	39.0
RS7025x24H	24(15~27)	0.18	4.32	4500	46.00	6.70	41.6
RS7025x24VH		0.20	4.8	5000	51.00	8.30	44.6

★ 如果您需要的转速或电压或功能不在这份清单上, 请与我们联系。  
If you want another rpm or voltage or functions which one is not in the list, please contact with our sales.

★ 提示1:功能的具体信息参照产品目录前页篇章。  
Notes1:The catalog have detail information in the front page for the functions.

★ 提示2:产品详细信息请参照承认书。  
Notes2:Product have a detail in the approval sheet.

★ 提示3:产品规格变更不另行通知。  
Notes3:Specifications are subject to change without notice.

# DC AXIAL FAN

## 70x70x25mm RS7025A Series



外框材质:环保防火PBT  
Frame:Thermoplastic PBT UL94-V0  
扇叶材质:环保防火PBT  
Impeller:Thermoplastic PBT UL94-V0  
轴承结构:双滚珠或长寿命含油结构  
Bearing system:2Ball or Long life sleeve  
单体风扇重量:78g  
Unit Weight:78g

DIMENSIONS DRAWING

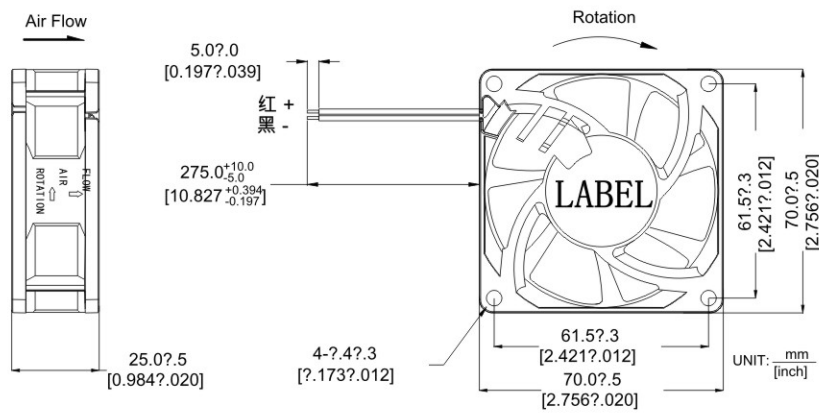

### 可选的功能参照列表 (Available Functions)

1.马达保护(Motor protection)

RP	SS	AS	CL
●	●	●	●

2.信号输出(Signal output)

FG	RD	RD	LD
●	●	●	●

3.调速方式(Speed control mode)

PWM	TP	VC	RC	CS
●	●	●	●	●

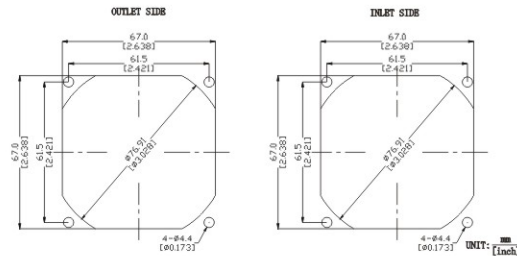
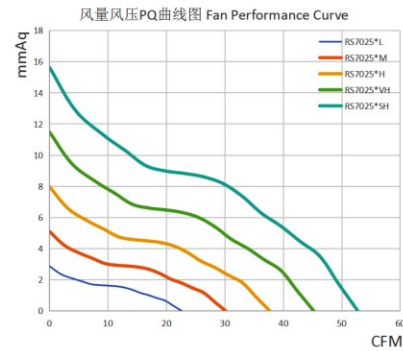

Part Number	Voltage(V)	Current(A)	Power(W)	Speed(RPM)	Air flow(Q)	Pressure(P)	Noise(dBA)
产品编号	电压范围	额定电流	功率	转速	(CFM) 风量	(mmAq)风压 (In H <sub>2</sub> O)	噪音
RS7025(X)12L	12(7~14)	0.06	0.72	3000	22.60	0.64	27.20
RS7025(X)12M		0.12	1.44	4000	30.13	0.85	35.60
RS7025(X)12H		0.20	2.40	5000	37.67	1.07	40.20
RS7025(X)12VH		0.34	4.08	6000	45.20	1.28	45.10
RS7025(X)12SH		0.50	6.00	7000	52.73	1.50	50.50
RS7025(X)24L	24(15~27)	0.03	0.72	3000	22.60	0.64	27.20
RS7025(X)24M		0.06	1.44	4000	30.13	0.85	35.60
RS7025(X)24H		0.10	2.40	5000	37.67	1.07	40.20
RS7025(X)24VH		0.17	4.08	6000	45.20	1.28	45.10
RS7025(X)24SH		0.25	6.00	7000	52.73	1.50	50.50
RS7025(X)48L	48(35~57)	0.02	0.96	3000	22.60	0.64	27.20
RS7025(X)48M		0.03	1.44	4000	30.13	0.85	35.60
RS7025(X)48H		0.05	2.40	5000	37.67	1.07	40.20
RS7025(X)48VH		0.09	4.32	6000	45.20	1.28	45.10
RS7025(X)48SH		0.13	6.24	7000	52.73	1.50	50.50

★ 如果您需要的转速或电压或功能不在这份清单上, 请与我们联系。  
If you want another rpm or voltage or functions which one is not in the list, please contact with our sales.

★ 提示1:功能的具体信息参照产品目录前页篇章。  
Notes1:The catalog have detail information in the front page for the functions.

★ 提示2:产品详细信息请参照承认书。  
Notes2:Product have a detail in the approval sheet.

★ 提示3:产品规格变更不另行通知。  
Notes3:Specifications are subject to change without notice.

# DC AXIAL FAN

## 75x75x20mm RS7520 Series



外框材质:铝合金  
Frame:Aluminum  
扇叶材质:环保防火PBT  
Impeller:Thermoplastic PBT UL94-V0  
轴承结构:双滚珠或长寿命含油结构  
Bearing system:2Ball or Long life sleeve  
单体风扇重量:95g  
Unit Weight:95g

DIMENSIONS DRAWING

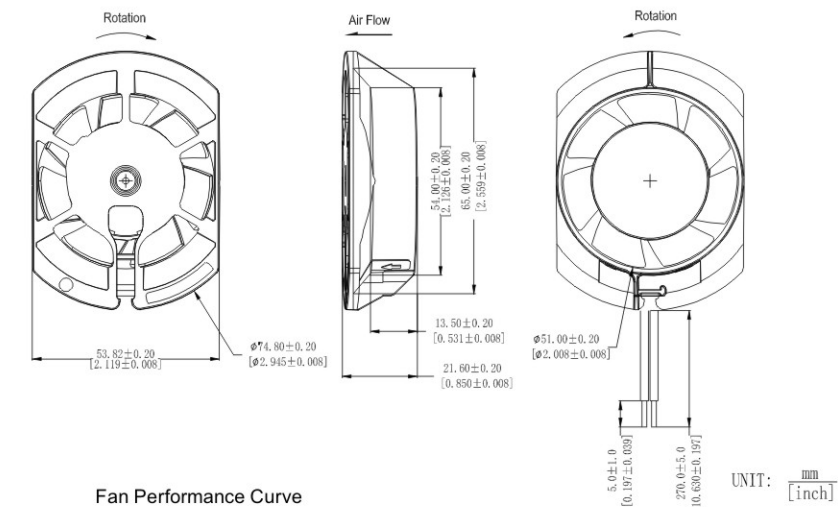

### 可选的功能参照列表 (Available Functions)

1.马达保护(Motor protection)

RP	SS	AS	CL
●	●	●	●

2.信号输出(Signal output)

FG	RD	RD	LD
●	●	●	●

3.调速方式(Speed control mode)

PWM	TP	VC	RC	CS
●	●	●	●	●

Fan Performance Curve

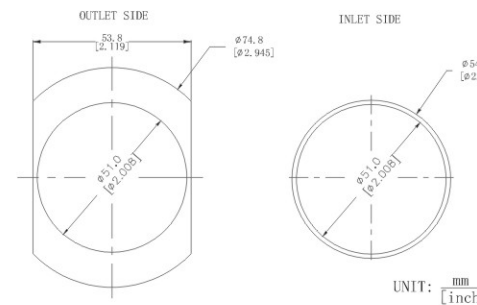
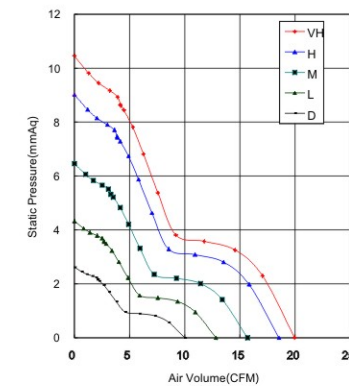

Part Number	Voltage(V)	Current(A)	Power(W)	Speed(RPM)	Air flow(Q)	Pressure(P)	Noise(dBA)
产品编号	电压范围	额定电流	功率	转速	(CFM) 风量	(mmAq)风压 (In H <sub>2</sub> O)	噪音
RS7520x05D	5(4~6)	0.14	0.70	3500	9.89	0.28	28.4
RS7520x05L		0.22	1.10	4500	12.83	0.36	32.5
RS7520x05M		0.33	1.65	5500	15.69	0.44	37.5
RS7520x12D	12(7~14)	0.06	0.72	3500	9.89	0.28	28.4
RS7520x12L		0.10	1.14	4500	12.83	0.36	32.5
RS7520x12M		0.14	1.68	5500	15.69	0.44	37.5
RS7520x12H		0.21	2.52	6500	18.54	0.52	39.2
RS7520x12VH		0.25	3.00	7000	19.96	0.56	42.0
RS7520x24D	24(15~27)	0.03	0.72	3500	9.89	0.28	28.4
RS7520x24L		0.05	1.20	4500	12.83	0.36	32.5
RS7520x24M		0.07	1.68	5500	15.69	0.44	37.5
RS7520x24H		0.11	2.64	6500	18.54	0.52	39.2
RS7520x24VH		0.13	3.12	7000	19.96	0.56	42.0

★ 如果您需要的转速或电压或功能不在这份清单上, 请与我们联系。  
If you want another rpm or voltage or functions which one is not in the list, please contact with our sales.

★ 提示1:功能的具体信息参照产品目录前页篇章。  
Notes1:The catalog have detail information in the front page for the functions.

★ 提示2:产品详细信息请参照承认书。  
Notes2:Product have a detail in the approval sheet.

★ 提示3:产品规格变更不另行通知。  
Notes3:Specifications are subject to change without notice.

## DC AXIAL FAN

### 80x80x10mm

#### RS8010 Series



DIMENSIONS DRAWING

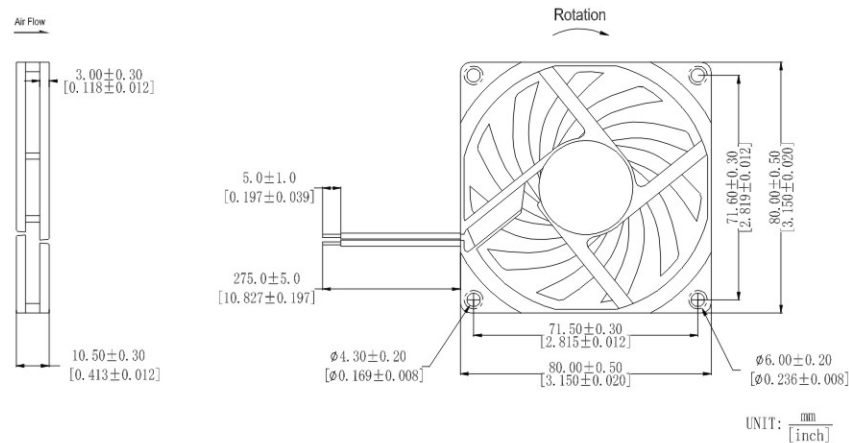

外框材质:环保防火PBT  
Frame:Thermoplastic PBT UL94-V0  
扇叶材质:环保防火PBT  
Impeller:Thermoplastic PBT UL94-V0  
轴承结构:双滚珠或长寿命含油结构  
Bearing system:2Ball or Long life sleeve  
单体风扇重量:48g  
Unit Weight:48g

#### 可选的功能参照列表 (Available Functions)

1.马达保护(Motor protection)

RP	SS	AS	CL
●	●	●	●

2.信号输出(Signal output)

FG	RD	RD	LD
●	●	●	●

3.调速方式(Speed control mode)

PWM	TP	VC	RC	CS
●	●	●	●	●

Fan Performance Curve

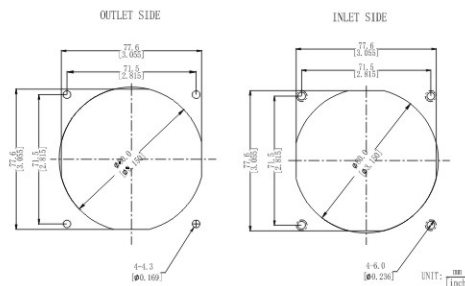
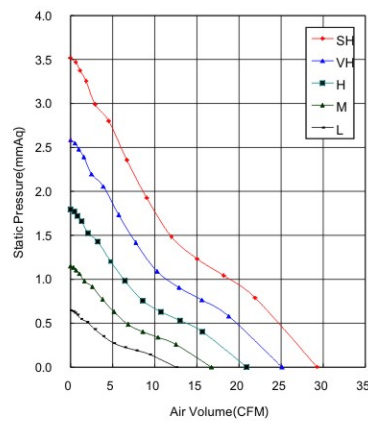

Part Number	Voltage(V)	Current(A)	Power(W)	Speed(RPM)	Air flow(Q)	Pressure(P)	Noise(dBA)
产品编号	电压范围	额定电流	功率	转速	(CFM) 风量	(mmAq)风压	(In H <sub>2</sub> O) 噪音
RS8010x05D	5(4~6)	0.08	0.38	1500	12.55	0.36	20.0
RS8010x05L		0.11	0.55	2000	16.73	0.47	22.6
RS8010x05M		0.21	1.05	2500	20.91	0.59	26.6
RS8010x12D	12(7~14)	0.03	0.36	1500	12.55	0.36	20.0
RS8010x12L		0.05	0.54	2000	16.73	0.47	22.6
RS8010x12M		0.09	1.02	2500	20.91	0.59	26.6
RS8010x12H		0.15	1.80	3000	25.10	0.71	31.3
RS8010x12VH		0.19	2.28	3500	29.28	0.83	34.6
RS8010x24M		24(15~27)	0.05	1.20	2500	20.91	0.59
RS8010x24H	0.08		1.92	3000	25.10	0.71	31.3
RS8010x24VH	0.10		2.40	3500	29.28	0.83	34.6

★如果您需要的转速或电压或功能不在这份清单上, 请与我们联系。  
If you want another rpm or voltage or functions which one is not in the list, please contact with our sales.

★提示1:功能的具体信息参照产品目录前页篇章。  
Notes 1: The catalog have detail information in the front page for the functions.

★提示2:产品详细信息请参照承认书。  
Notes 2: Product have a detail in the approval sheet.

★提示3:产品规格变更不另行通知。  
Notes 3: Specifications are subject to change without notice.

## DC AXIAL FAN

### 80x80x15mm

#### RS8015 Series



DIMENSIONS DRAWING

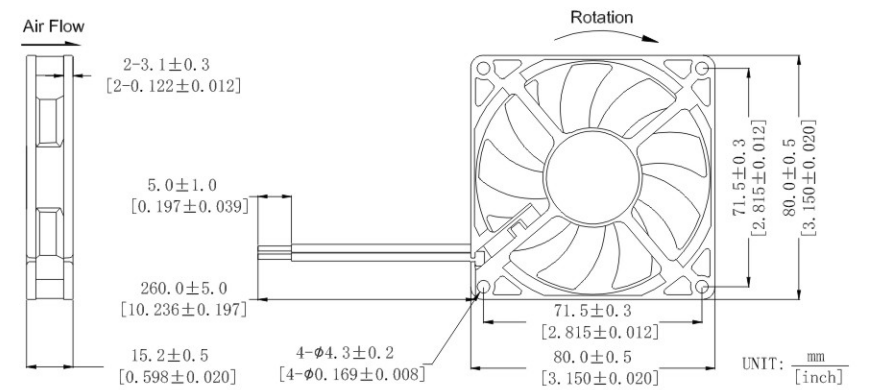

外框材质:环保防火PBT  
Frame:Thermoplastic PBT UL94-V0  
扇叶材质:环保防火PBT  
Impeller:Thermoplastic PBT UL94-V0  
轴承结构:双滚珠或长寿命含油结构  
Bearing system:2Ball or Long life sleeve  
单体风扇重量:48g  
Unit Weight:48g

#### 可选的功能参照列表 (Available Functions)

1.马达保护(Motor protection)

RP	SS	AS	CL
●	●	●	●

2.信号输出(Signal output)

FG	RD	RD	LD
●	●	●	●

3.调速方式(Speed control mode)

PWM	TP	VC	RC	CS
●	●	●	●	●

Fan Performance Curve

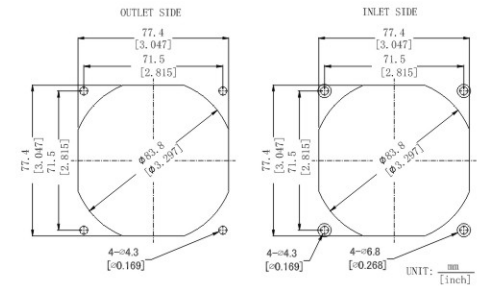
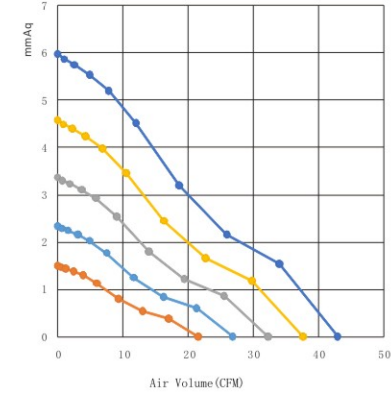

Part Number	Voltage(V)	Current(A)	Power(W)	Speed(RPM)	Air flow(Q)	Pressure(P)	Noise(dBA)
产品编号	电压范围	额定电流	功率	转速	(CFM) 风量	(mmAq)风压	(In H <sub>2</sub> O) 噪音
RS8015X05L	5(4~6)	0.15	0.75	2000	21.47	0.61	28.9
RS8015X05M		0.23	1.15	2500	26.84	0.76	32.1
RS8015X12L		12(7~14)	0.07	0.84	2000	21.47	0.61
RS8015X12M	0.1		1.2	2500	26.84	0.76	32.1
RS8015X12H	0.16		1.92	3000	32.21	0.91	37.3
RS8015X12VH	0.23		2.76	3500	37.58	1.06	42.5
RS8015X12SH	0.28		3.36	4000	42.95	1.21	47.3
RS8015X24L	24(15~27)		0.04	0.96	2000	21.47	0.61
RS8015X24M		0.06	1.44	2500	26.84	0.76	32.1
RS8015X24H		0.08	1.92	3000	32.21	0.91	37.3
RS8015X24VH		0.12	2.88	3500	37.58	1.06	42.5
RS8015X24SH		0.14	3.36	4000	42.95	1.21	47.3

★如果您需要的转速或电压或功能不在这份清单上, 请与我们联系。  
If you want another rpm or voltage or functions which one is not in the list, please contact with our sales.

★提示1:功能的具体信息参照产品目录前页篇章。  
Notes 1: The catalog have detail information in the front page for the functions.

★提示2:产品详细信息请参照承认书。  
Notes 2: Product have a detail in the approval sheet.

★提示3:产品规格变更不另行通知。  
Notes 3: Specifications are subject to change without notice.

## DC AXIAL FAN

### 80x80x20mm

#### RS8020 Series



DIMENSIONS DRAWING

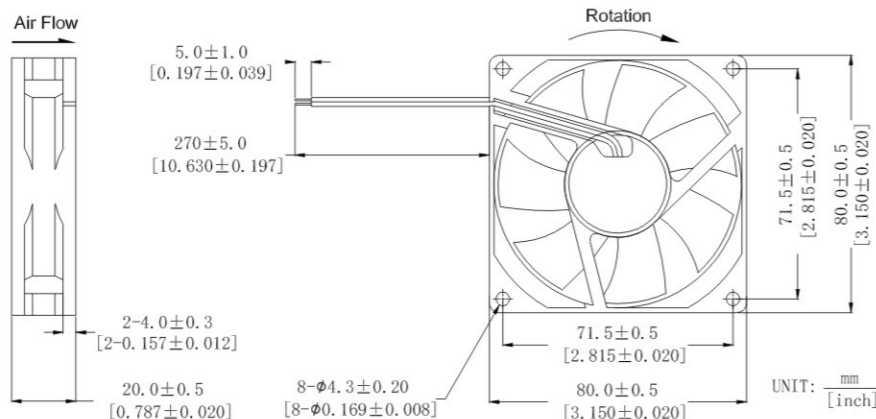

外框材质:环保防火PBT  
Frame:Thermoplastic PBT UL94-V0  
扇叶材质:环保防火PBT  
Imperller:Thermoplastic PBT UL94-V0  
轴承结构:双滚珠或长寿命含油结构  
Bearing system:2Ball or Long life sleeve  
单体风扇重量:52g  
Unit Weight:52g

#### 可选的功能参照列表 (Available Functions)

1.马达保护(Motor protection)

RP	SS	AS	CL
●	●	●	●

2.信号输出(Signal output)

FG	RD	RD	LD
●	●	●	●

3.调速方式(Speed control mode)

PWM	TP	VC	RC	CS
●	●	●	●	●

Fan Performance Curve

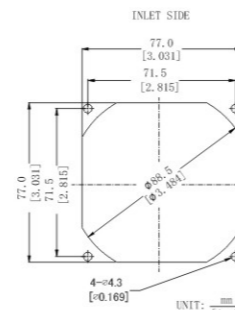
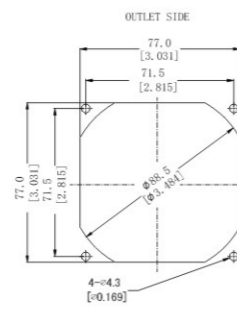
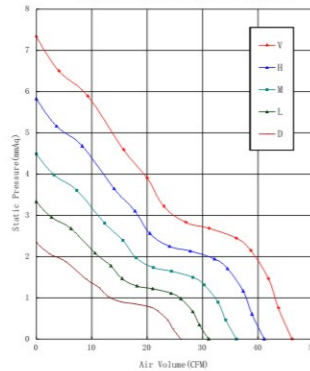

Part Number	Voltage(V)	Current(A)	Power(W)	Speed(RPM)	Air flow(Q)	Pressure(P)	Noise(dBA)
产品编号	电压范围	额定电流	功率	转速	(CFM) 风量	(mmAq)风压 (In H <sub>2</sub> O)	噪音
RS8020x12D	12(7~14)	0.12	1.44	2500	26.08	0.74	27.2
RS8020x12L		0.16	1.92	3000	31.10	0.88	32.8
RS8020x12M		0.22	2.64	3500	36.12	1.02	36.0
RS8020x12H		0.28	3.36	4000	41.13	1.16	40.4
RS8020x12VH		0.34	4.08	4500	46.15	1.31	43.3
RS8020x24D		24(15~27)	0.06	1.44	2500	26.08	0.74
RS8020x24L	0.08		1.92	3000	31.10	0.88	32.8
RS8020x24M	0.11		2.64	3500	36.12	1.02	36.0
RS8020x24H	0.14		3.36	4000	41.13	1.16	40.4
RS8020x24VH	0.17		4.08	4500	46.15	1.31	43.3

★ 如果您需要的转速或电压或功能不在这份清单上, 请与我们联系。  
If you want another rpm or voltage or functions which one is not in the list, please contact with our sales.

★ 提示1:功能的具体信息参照产品目录前页篇章。  
Notes1:The catalog have detail information in the front page for the functions.

★ 提示2:产品详细信息请参照承认书。  
Notes2:Product have a detail in the approval sheet.

★ 提示3:产品规格变更不另行通知。  
Notes3:Specifications are subject to change without notice.

## DC AXIAL FAN

### 80x80x20mm

#### RS8020 A Series



DIMENSIONS DRAWING

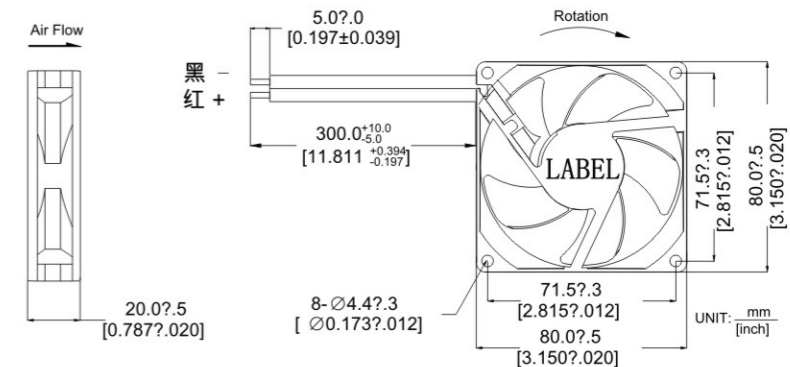

外框材质:环保防火PBT  
Frame:Thermoplastic PBT UL94-V0  
扇叶材质:环保防火PBT  
Imperller:Thermoplastic PBT UL94-V0  
轴承结构:双滚珠或长寿命含油结构  
Bearing system:2Ball or Long life sleeve  
单体风扇重量:48g  
Unit Weight:48g

#### 可选的功能参照列表 (Available Functions)

1.马达保护(Motor protection)

RP	SS	AS	CL
●	●	●	●

2.信号输出(Signal output)

FG	RD	RD	LD
●	●	●	●

3.调速方式(Speed control mode)

PWM	TP	VC	RC	CS
●	●	●	●	●

风量风压PQ曲线图 Fan Performance Curve

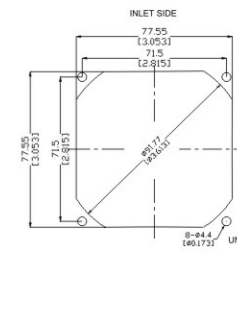
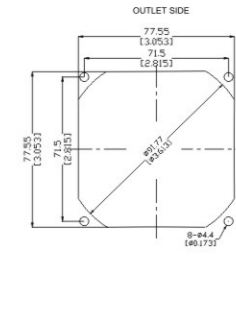
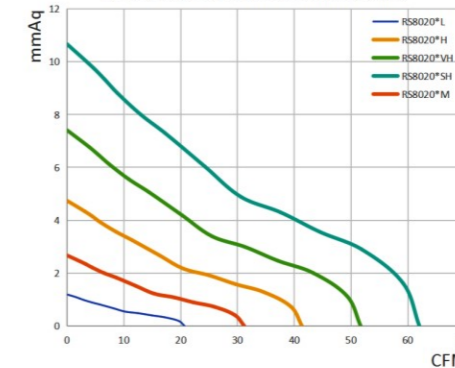

Part Number	Voltage(V)	Current(A)	Power(W)	Speed(RPM)	Air flow(Q)	Pressure(P)	Noise(dBA)
产品编号	电压范围	额定电流	功率	转速	(CFM)风量	(mmAq)风压 (In H <sub>2</sub> O)	噪音
RS8020(X)12L	12(7~14)	0.03	0.36	2000	20.68	0.59	22.08
RS8020(X)12M		0.07	0.84	3000	31.20	0.89	29.13
RS8020(X)12H		0.13	1.56	4000	41.36	1.17	36.48
RS8020(X)12VH		0.24	2.88	5000	51.70	1.47	41.63
RS8020(X)12SH		0.42	5.04	6000	62.04	1.76	47.26
RS8020(X)24L		24(15~27)	0.02	0.48	2000	20.68	0.59
RS8020(X)24M	0.04		0.96	3000	31.20	0.89	29.13
RS8020(X)24H	0.07		1.68	4000	41.36	1.17	36.48
RS8020(X)24VH	0.12		2.88	5000	51.70	1.47	41.63
RS8020(X)24SH	0.21		5.04	6000	62.04	1.76	47.26
RS8020(X)48L	48(35~57)		0.01	0.48	2000	20.68	0.59
RS8020(X)48M		0.02	0.96	3000	31.20	0.89	29.13
RS8020(X)48H		0.04	1.92	4000	41.36	1.17	36.48
RS8020(X)48VH		0.06	2.88	5000	51.70	1.47	41.63
RS8020(X)48SH	0.11	5.28	6000	62.04	1.76	47.26	

★ 如果您需要的转速或电压或功能不在这份清单上, 请与我们联系。  
If you want another rpm or voltage or functions which one is not in the list, please contact with our sales.

★ 提示1:功能的具体信息参照产品目录前页篇章。  
Notes1:The catalog have detail information in the front page for the functions.

★ 提示2:产品详细信息请参照承认书。  
Notes2:Product have a detail in the approval sheet.

★ 提示3:产品规格变更不另行通知。  
Notes3:Specifications are subject to change without notice.

## DC AXIAL FAN

### 80x80x25mm RS8025 Series



外框材质:环保防火PBT  
Frame:Thermoplastic PBT UL94-V0  
扇叶材质:环保防火PBT  
Impeller:Thermoplastic PBT UL94-V0  
轴承结构:双滚珠或长寿命含油结构  
Bearing system:2Ball or Long life sleeve  
单体风扇重量:54g  
Unit Weight:54g

DIMENSIONS DRAWING

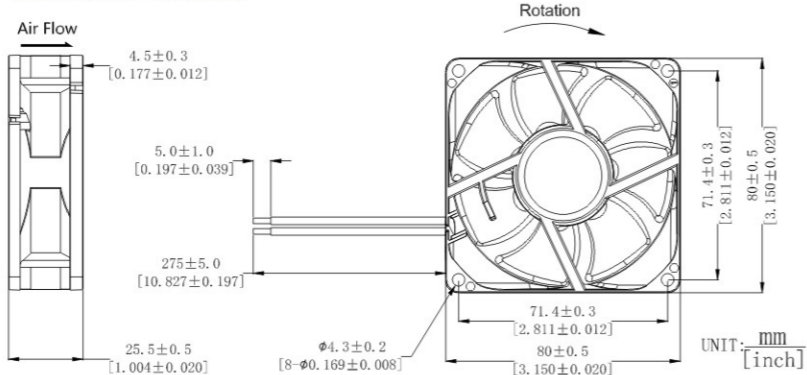

Fan Performance Curve

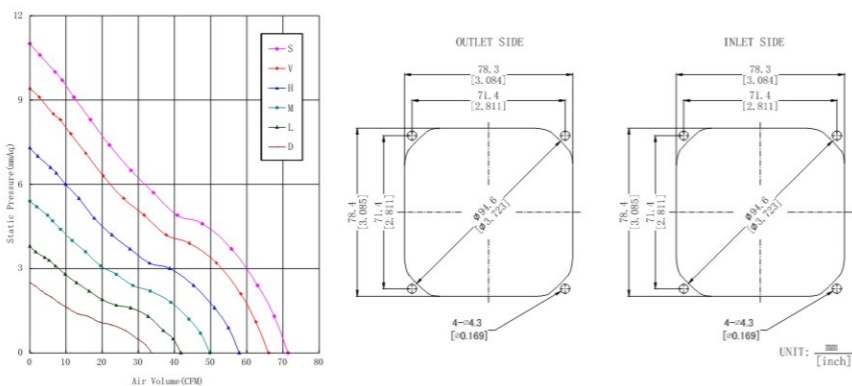

#### 可选的功能参照列表 (Available Functions)

##### 1.马达保护(Motor protection)

RP	SS	AS	CL
●	●	●	●

##### 2.信号输出(Signal output)

FG	RD	RD	LD
●	●	●	●

##### 3.调速方式(Speed control mode)

PWM	TP	VC	RC	CS
●	●	●	●	●

Part Number	Voltage(V)	Current(A)	Power(W)	Speed(RPM)	Air flow(Q)	Pressure(P)	Noise(dBA)		
产品编号	电压范围	额定电流	功率	转速	(CFM) 风量	m <sup>3</sup> /min	(mmAq)风压 (In H <sub>2</sub> O)	噪音	
RS8025x12L	12(7~14)	0.20	2.40	3000	43.23	1.22	3.77	0.15	31.5
RS8025x12M		0.22	2.64	3600	51.59	1.46	5.37	0.21	38.1
RS8025x12H		0.31	3.72	4200	59.96	1.70	7.25	0.29	41.5
RS8025x12VH		0.40	4.80	4800	68.33	1.93	9.42	0.37	44.2
RS8025x12SH		0.55	6.60	5200	73.91	2.09	11.02	0.43	46.8
RS8025B12UH		0.70A	8.4	6200	83.52	2.36	15.09	0.59	52
RS8025x24L	24(15~27)	0.10	2.40	3000	43.23	1.22	3.77	0.15	31.5
RS8025x24M		0.11	2.64	3600	51.59	1.46	5.37	0.21	38.1
RS8025x24H		0.15	3.60	4200	59.96	1.70	7.25	0.29	41.5
RS8025x24VH		0.20	4.80	4800	68.33	1.93	9.42	0.37	44.2
RS8025x24SH		0.28	6.72	5200	73.91	2.09	11.02	0.43	46.8
RS8025B24UH		0.35	8.4	6200	83.52	2.36	15.09	0.59	52
RS8025x48L	48(35~57)	0.05	2.40	3000	43.23	1.22	3.77	0.15	31.5
RS8025x48M		0.06	2.88	3600	51.59	1.46	5.37	0.21	38.1
RS8025x48H		0.08	3.84	4200	59.96	1.70	7.25	0.29	41.5
RS8025x48VH		0.10	4.80	4800	68.33	1.93	9.42	0.37	44.2
RS8025x48SH		0.14	6.72	5200	73.91	2.09	11.02	0.43	46.8
RS8025B48UH		0.18	8.64	6200	83.52	2.36	15.09	0.59	52

★如果您需要的转速或电压或功能不在这份清单上, 请与我们联系。  
If you want another rpm or voltage or functions which one is not in the list, please contact with our sales.

★提示1:功能的具体信息参照产品目录前页篇章。  
Notes1:The catalog have detail information in the front page for the functions.

★提示2:产品详细信息请参照承认书。  
Notes2:Product have a detail in the approval sheet.

★提示3:产品规格变更不另行通知。  
Notes3:Specifications are subject to change without notice.

## DC AXIAL FAN

### 80x80x25mm RD8025 Series



外框材质:环保防火PBT  
Frame:Thermoplastic PBT UL94-V0  
扇叶材质:环保防火PBT  
Impeller:Thermoplastic PBT UL94-V0  
轴承结构:双滚珠或长寿命含油结构  
Bearing system:2Ball or Long life sleeve  
单体风扇重量:75g  
Unit Weight:75g

DIMENSIONS DRAWING

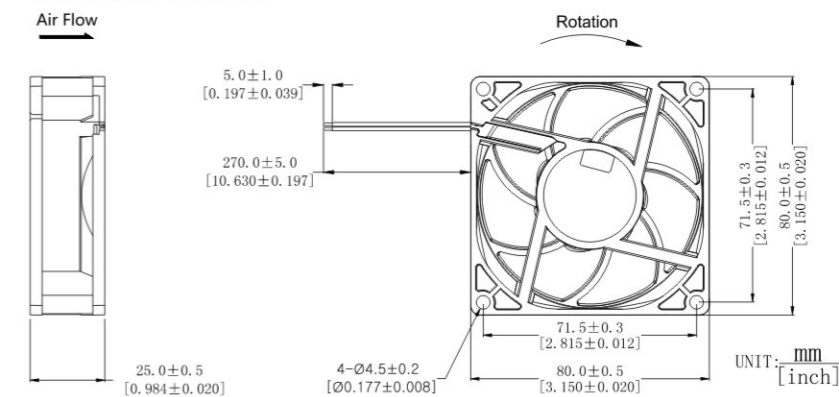

Fan Performance Curve

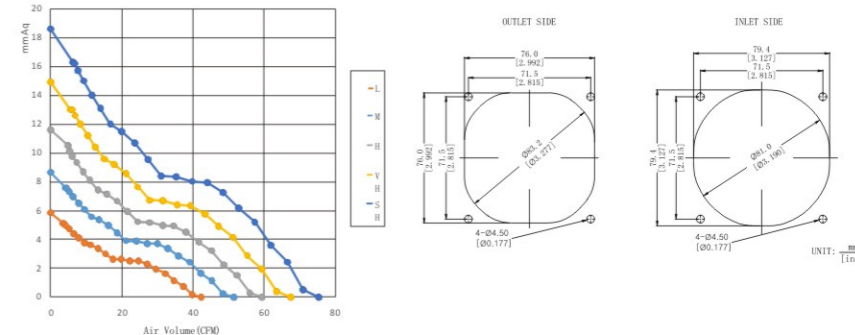

#### 可选的功能参照列表 (Available Functions)

##### 1.马达保护(Motor protection)

RP	SS	AS	CL
●	●	●	●

##### 2.信号输出(Signal output)

FG	RD	RD	LD
●	●	●	●

##### 3.调速方式(Speed control mode)

PWM	TP	VC	RC	CS
●	●	●	●	●

Part Number	Voltage(V)	Current(A)	Power(W)	Speed(RPM)	Air flow(Q)	Pressure(P)	Noise(dBA)		
产品编号	电压范围	额定电流	功率	转速	(CFM) 风量	m <sup>3</sup> /min	(mmAq)风压 (In H <sub>2</sub> O)	噪音	
RD8025X12L	12(7~14)	0.1	1.2	3700	42.28	1.2	5.85	0.23	30.98
RD8025X12M		0.16	1.92	4500	51.42	1.45	8.65	0.34	36.79
RD8025X12H		0.26	3.12	5200	59.42	1.68	11.55	0.45	40.26
RD8025X12VH		0.34	4.08	5900	67.42	1.91	14.87	0.59	45.01
RD8025X12SH		0.46	5.52	6600	75.41	2.13	18.61	0.73	50.25
RD8025X24L		24(15~27)	0.05	1.2	3700	42.28	1.2	5.85	0.23
RD8025X24M	0.08		1.92	4500	51.42	1.45	8.65	0.34	36.79
RD8025X24H	0.13		3.12	5200	59.42	1.68	11.55	0.45	40.26
RD8025X24VH	0.17		4.08	5900	67.42	1.91	14.87	0.59	45.01
RD8025X24SH	0.23		5.52	6600	75.41	2.13	18.61	0.73	50.25
RD8025X48M	48(35~57)		0.05	2.4	4500	51.42	1.45	8.65	0.34
RD8025X48H		0.07	3.36	5200	59.42	1.68	11.55	0.45	40.26
RD8025X48VH		0.09	4.32	5900	67.42	1.91	14.87	0.59	45.01
RD8025X48SH		0.11	5.28	6600	75.41	2.13	18.61	0.73	50.25

★如果您需要的转速或电压或功能不在这份清单上, 请与我们联系。  
If you want another rpm or voltage or functions which one is not in the list, please contact with our sales.

★提示1:功能的具体信息参照产品目录前页篇章。  
Notes1:The catalog have detail information in the front page for the functions.

★提示2:产品详细信息请参照承认书。  
Notes2:Product have a detail in the approval sheet.

★提示3:产品规格变更不另行通知。  
Notes3:Specifications are subject to change without notice.

# DC AXIAL FAN

## 80x80x25mm

### RD8025A Series

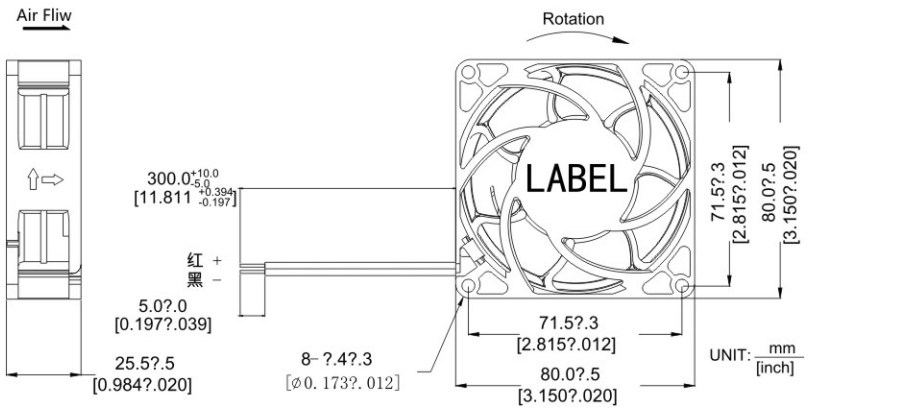

外框材质:环保防火PBT  
Frame:Thermoplastic PBT UL94-V0  
扇叶材质:环保防火PBT  
Impeller:Thermoplastic PBT UL94-V0  
轴承结构:双滚珠或长寿命含油结构  
Bearing system:2Ball or Long life sleeve  
单体风扇重量:75g  
Unit Weight:75g

#### 可选的功能参照列表 (Available Functions)

##### 1.马达保护(Motor protection)

RP	SS	AS	CL
<input type="checkbox"/>	<input type="checkbox"/>	<input type="checkbox"/>	<input type="checkbox"/>

##### 2.信号输出(Signal output)

FG	RD	RD	LD
<input type="checkbox"/>	<input type="checkbox"/>	<input type="checkbox"/>	<input type="checkbox"/>

##### 3.调速方式(Speed control mode)

PWM	TP	VC	RC	CS
<input type="checkbox"/>	<input type="checkbox"/>	<input type="checkbox"/>	<input type="checkbox"/>	<input type="checkbox"/>

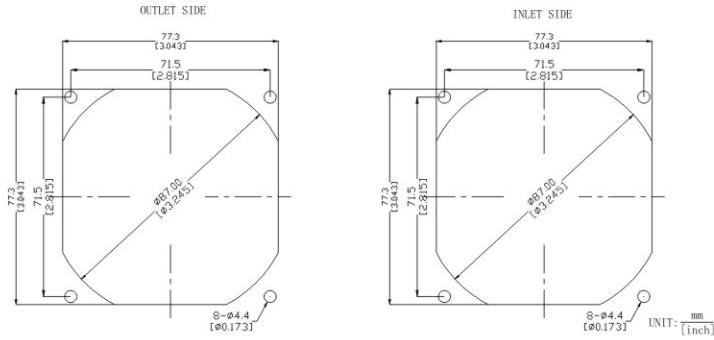
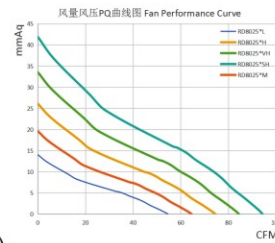

Part Number	Voltage(V)	Current(A)	Power(W)	Speed(RPM)	Air flow(Q)	Pressure(P)	Noise(dBA)
产品编号	电压范围	额定电流	功率	转速	(CFM) 风量	(mmAq)风压	(In H <sub>2</sub> O) 噪音
RD8025B12L2	12(7~14)	0.28	3.36	5500	54.60	1.55	43.21
RD8025B12M2		0.43	5.16	6500	64.53	1.83	47.51
RD8025B12H2		0.64	7.68	7500	74.45	2.11	53.57
RD8025B12VH2		0.97	11.64	8500	84.38	2.39	57.42
RD8025B12SH2		1.35	16.20	9500	94.31	2.68	62.01
RD8025B24L2		24(15~27)	0.14	3.36	5500	54.60	1.55
RD8025B24M2	0.22		5.28	6500	64.53	1.83	47.51
RD8025B24H2	0.32		7.68	7500	74.45	2.11	53.57
RD8025B24VH2	0.49		11.76	8500	84.38	2.39	57.42
RD8025B24SH2	0.68		16.32	9500	94.31	2.68	62.01
RD8025B48L2	48(35~57)		0.07	3.36	5500	54.60	1.55
RD8025B48M2		0.11	5.28	6500	64.53	1.83	47.51
RD8025B48H2		0.16	7.68	7500	74.45	2.11	53.57
RD8025B48VH2		0.25	12.00	8500	84.38	2.39	57.42
RD8025B48SH2		0.34	16.32	9500	94.31	2.68	62.01

★ 如果您需要的转速或电压或功能不在这份清单上, 请与我们联系。  
If you want another rpm or voltage or functions which one is not in the list, please contact with our sales.

★ 提示1:功能的具体信息参照产品目录前页篇章。  
Notes1:The catalog have detail information in the front page for the functions.

★ 提示2:产品详细信息请参照承认书。  
Notes2:Product have a detail in the approval sheet.

★ 提示3:产品规格变更不另行通知。  
Notes3:Specifications are subject to change without notice.

# DC AXIAL FAN

## 80x80x32mm

### RD8032 Series



外框材质:环保防火PBT  
Frame:Thermoplastic PBT UL94-V0  
扇叶材质:环保防火PBT  
Impeller:Thermoplastic PBT UL94-V0  
轴承结构:双滚珠或长寿命含油结构  
Bearing system:2Ball or Long life sleeve  
单体风扇重量:95g  
Unit Weight:95g

#### 可选的功能参照列表 (Available Functions)

##### 1.马达保护(Motor protection)

RP	SS	AS	CL
<input type="checkbox"/>	<input type="checkbox"/>	<input type="checkbox"/>	<input type="checkbox"/>

##### 2.信号输出(Signal output)

FG	RD	RD	LD
<input type="checkbox"/>	<input type="checkbox"/>	<input type="checkbox"/>	<input type="checkbox"/>

##### 3.调速方式(Speed control mode)

PWM	TP	VC	RC	CS
<input type="checkbox"/>	<input type="checkbox"/>	<input type="checkbox"/>	<input type="checkbox"/>	<input type="checkbox"/>

#### DIMENSIONS DRAWING

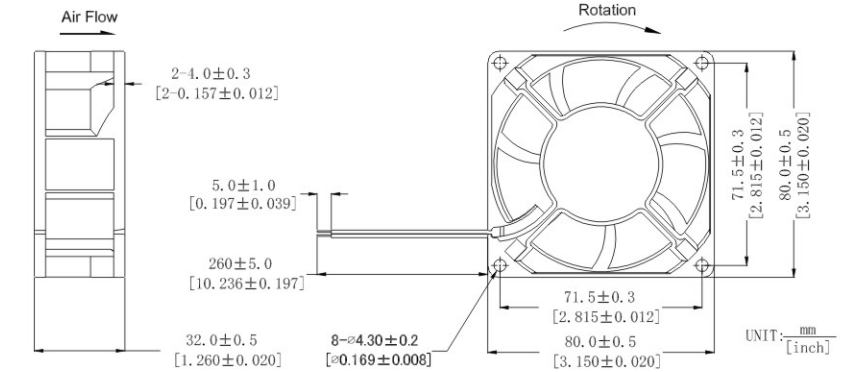

#### Fan Performance Curve

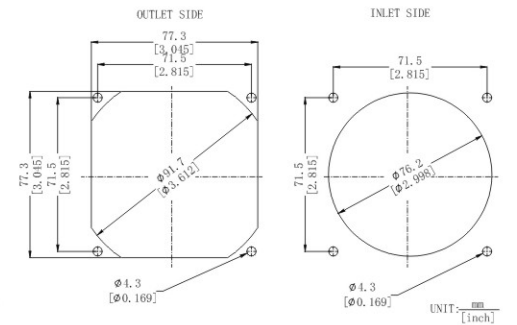
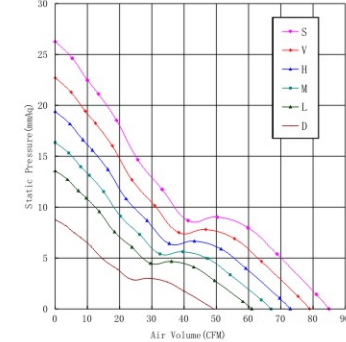

Part Number	Voltage(V)	Current(A)	Power(W)	Speed(RPM)	Air flow(Q)	Pressure(P)	Noise(dBA)
产品编号	电压范围	额定电流	功率	转速	(CFM) 风量	(mmAq)风压	(In H <sub>2</sub> O) 噪音
RD8032X12D	12(7~14)	0.24	2.88	4000	49.02	1.38	37.7
RD8032X12L		0.42	5.04	5000	60.98	1.72	41.6
RD8032X12M		0.54	6.48	5500	66.96	1.89	45.2
RD8032X12H		0.70	8.4	6000	72.94	2.06	48.6
RD8032X12VH		0.86	10.32	6500	78.92	2.23	50.4
RD8032X12SH		1.00	12	7000	84.90	2.40	52.0
RD8032X24D	24(15~27)	0.12	2.88	4000	49.02	1.38	37.7
RD8032X24L		0.21	5.04	5000	60.98	1.72	41.6
RD8032X24M		0.27	6.48	5500	66.96	1.89	45.2
RD8032X24H		0.35	8.4	6000	72.94	2.06	48.6
RD8032X24VH		0.43	10.32	6500	78.92	2.23	50.4
RD8032X24SH		0.50	12	7000	84.90	2.40	52.0
RD8032X48D	48(35~57)	0.06	2.88	4000	49.02	1.38	37.7
RD8032X48L		0.11	5.28	5000	60.98	1.72	41.6
RD8032X48M		0.13	6.24	5500	66.96	1.89	45.2
RD8032X48H		0.17	8.16	6000	72.94	2.06	48.6
RD8032X48VH		0.21	10.08	6500	78.92	2.23	50.4
RD8032X48SH		0.25	12	7000	84.90	2.40	52.0

★ 如果您需要的转速或电压或功能不在这份清单上, 请与我们联系。  
If you want another rpm or voltage or functions which one is not in the list, please contact with our sales.

★ 提示1:功能的具体信息参照产品目录前页篇章。  
Notes1:The catalog have detail information in the front page for the functions.

★ 提示2:产品详细信息请参照承认书。  
Notes2:Product have a detail in the approval sheet.

★ 提示3:产品规格变更不另行通知。  
Notes3:Specifications are subject to change without notice.

# DC AXIAL FAN

## 80x80x38mm

### RD8038 Series



外框材质:环保防火PBT  
 Frame:Thermoplastic PBT UL94-V0  
 扇叶材质:环保防火PBT  
 Impeller:Thermoplastic PBT UL94-V0  
 轴承结构:双滚珠或长寿命含油结构  
 Bearing system:2Ball or Long life sleeve  
 单体风扇重量:153g  
 Unit Weight:153g

DIMENSIONS DRAWING

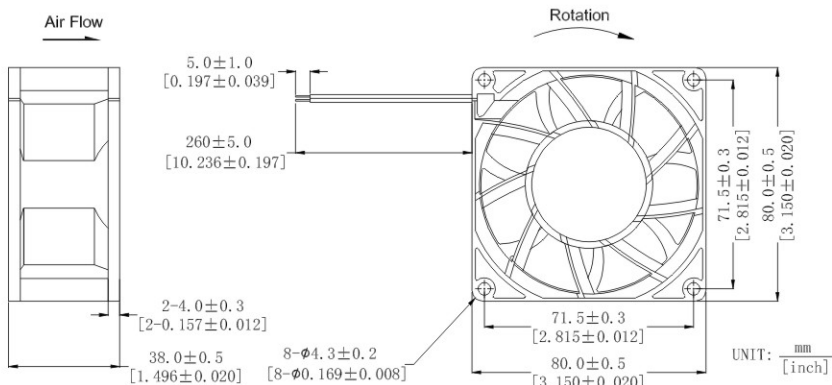

Fan Performance Curve

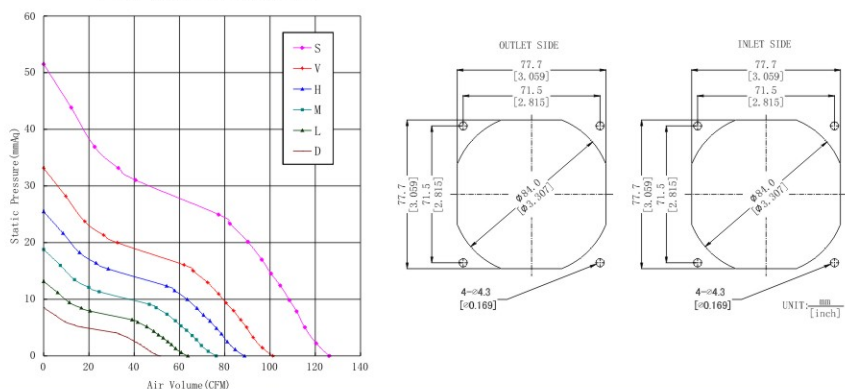

#### 可选的功能参照列表 (Available Functions)

1. 马达保护(Motor protection)

RP	SS	AS	CL
●	●	●	●

2. 信号输出(Signal output)

FG	RD	RD	LD
●	●	●	●

3. 调速方式(Speed control mode)

PWM	TP	VC	RC	CS
●	●	●	●	●

Part Number	Voltage(V)	Current(A)	Power(W)	Speed(RPM)	Air flow(Q)	Pressure(P)	Noise(dBA)
产品编号	电压范围	额定电流	功率	转速	(CFM) 风量	(mmAq)风压 (In H <sub>2</sub> O)	噪音
RD8038X12D	12(7~14)	0.26	3.12	4000	51.23	1.45	38.80
RD8038X12L		0.38	4.56	5000	63.72	1.80	44.50
RD8038X12M		0.66	7.92	6000	76.22	2.16	50.20
RD8038X12H		1.00	12.00	7000	88.72	2.51	55.70
RD8038X12VH	24(15~27)	1.24	14.88	8000	101.21	2.86	58.50
RD8038X24D		0.13	3.12	4000	51.23	1.45	38.80
RD8038X24L		0.16	3.84	5000	63.72	1.80	44.50
RD8038X24M		0.33	7.92	6000	76.22	2.16	50.20
RD8038X24H	48(35~57)	0.50	12.00	7000	88.72	2.51	55.70
RD8038X24VH		0.62	14.88	8000	101.21	2.86	58.50
RD8038X24SH		1.20	28.80	10000	126.21	3.57	64.60
RD8038X48D		0.06	2.88	4000	51.23	1.45	38.80
RD8038X48L	48(35~57)	0.08	3.84	5000	63.72	1.80	44.50
RD8038X48M		0.16	7.68	6000	76.22	2.16	50.20
RD8038X48H		0.25	12.00	7000	88.72	2.51	55.70
RD8038X48VH		0.31	14.88	8000	101.21	2.86	58.50
RD8038X48SH		0.60	28.80	10000	126.21	3.57	64.60

★ 如果您需要的转速或电压或功能不在这份清单上, 请与我们联系。  
 If you want another rpm or voltage or functions which one is not in the list, please contact with our sales.

★ 提示1: 功能的具体信息参照产品目录前页篇章。  
 Notes1: The catalog have detail information in the front page for the functions.

★ 提示2: 产品详细信息请参照承认书。  
 Notes2: Product have a detail in the approval sheet.

★ 提示3: 产品规格变更不另行通知。  
 Notes3: Specifications are subject to change without notice.

# DC AXIAL FAN

## 80x80x38mm

### RD8038 Series



外框材质:环保防火PBT  
 Frame:Thermoplastic PBT UL94-V0  
 扇叶材质:环保防火PBT  
 Impeller:Thermoplastic PBT UL94-V0  
 轴承结构:双滚珠或长寿命含油结构  
 Bearing system:2Ball or Long life sleeve  
 单体风扇重量:153g  
 Unit Weight:153g

DIMENSIONS DRAWING

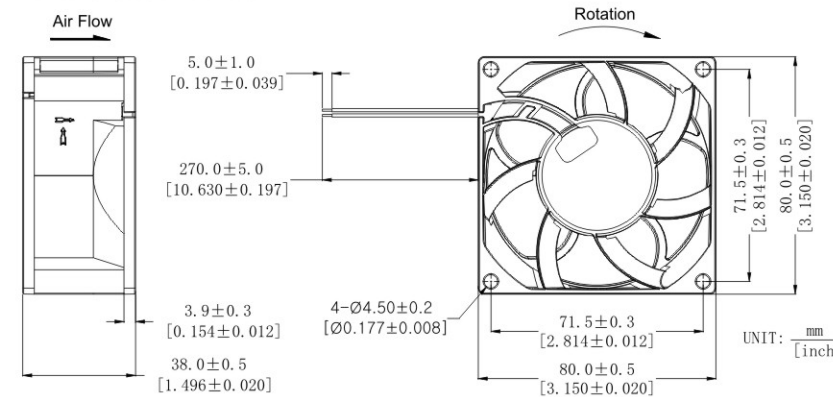

Fan Performance Curve

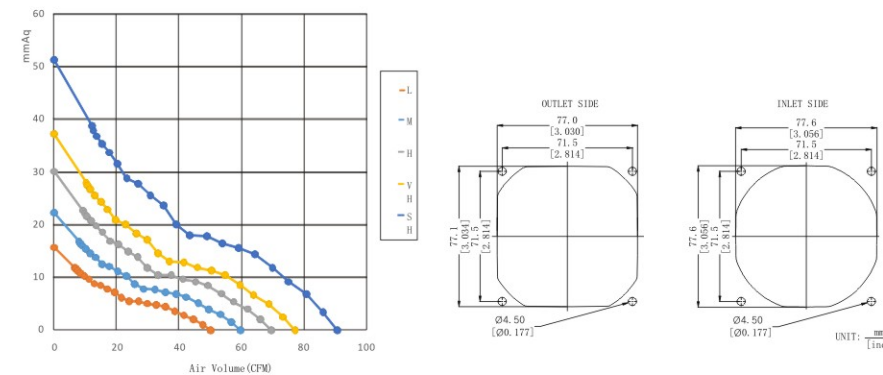

#### 可选的功能参照列表 (Available Functions)

1. 马达保护(Motor protection)

RP	SS	AS	CL
●	●	●	●

2. 信号输出(Signal output)

FG	RD	RD	LD
●	●	●	●

3. 调速方式(Speed control mode)

PWM	TP	VC	RC	CS
●	●	●	●	●

Part Number	Voltage(V)	Current(A)	Power(W)	Speed(RPM)	Air flow(Q)	Pressure(P)	Noise(dBA)
产品编号	电压范围	额定电流	功率	转速	(CFM) 风量	(mmAq)风压 (In H <sub>2</sub> O)	噪音
RD8038X12L	12(7~14)	0.25	3	5200	50.19	1.42	41.99
RD8038X12M		0.42	5.04	6200	59.83	1.69	47.04
RD8038X12H		0.61	7.32	7200	69.49	1.97	49.93
RD8038X24L	24(15~27)	0.12	2.88	5200	50.19	1.42	41.99
RD8038X24M		0.21	5.04	6200	59.83	1.69	47.04
RD8038X24H		0.31	7.44	7200	69.49	1.97	49.93
RD8038X24VH		0.42	10.08	8000	77.21	2.18	53.66
RD8038X24SH	48(35~57)	0.72	17.28	9400	90.72	2.57	59.35
RD8038X48L		0.07	3.36	5200	50.19	1.42	41.99
RD8038X48M		0.11	5.28	6200	59.83	1.69	47.04
RD8038X48H		0.14	6.72	7200	69.49	1.97	49.93
RD8038X48VH	48(35~57)	0.22	10.56	8000	77.21	2.18	53.66
RD8038X48SH		0.37	17.76	9400	90.72	2.57	59.35

★ 如果您需要的转速或电压或功能不在这份清单上, 请与我们联系。  
 If you want another rpm or voltage or functions which one is not in the list, please contact with our sales.

★ 提示1: 功能的具体信息参照产品目录前页篇章。  
 Notes1: The catalog have detail information in the front page for the functions.

★ 提示2: 产品详细信息请参照承认书。  
 Notes2: Product have a detail in the approval sheet.

★ 提示3: 产品规格变更不另行通知。

# DC AXIAL FAN

## 80X80X56mm

### RD8038AJ Series



DIMENSIONS DRAWING

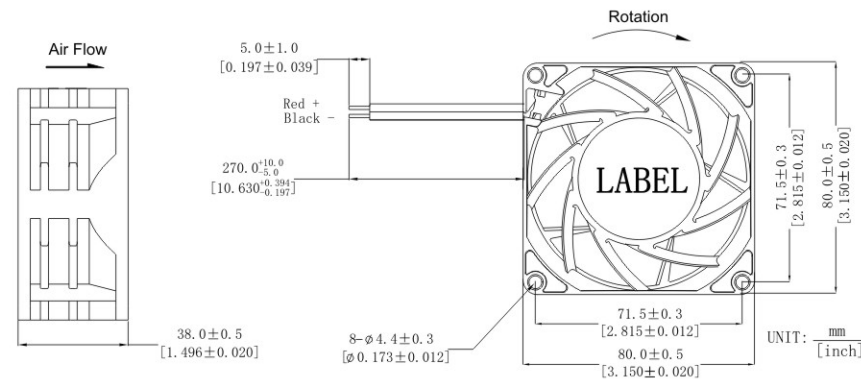

外框材质:环保防火PBT  
Frame:Thermoplastic PBT UL94-V0  
扇叶材质:环保防火PBT  
Impeller:Thermoplastic PBT UL94-V0  
轴承结构:双滚珠或长寿命含油结构  
Bearing system:2Ball or Long life sleeve  
单体风扇重量:153g  
Unit Weight:153g

#### 可选的功能参照列表 (Available Functions)

1.马达保护(Motor protection)

RP	SS	AS	CL
●	●	●	●

2.信号输出(Signal output)

FG	RD	RD	LD
●	●	●	●

3.调速方式(Speed control mode)

PWM	TP	VC	RC	CS
●	●	●	●	●

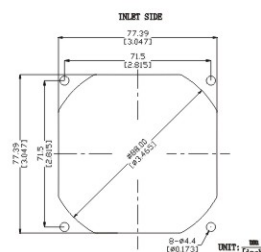
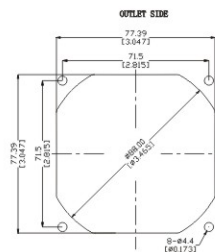
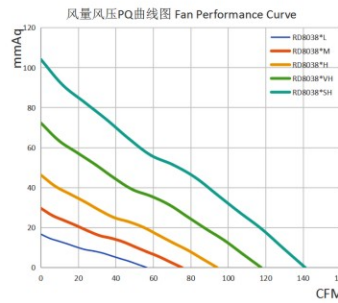

Part Number	Voltage(V)	Current(A)	Power(W)	Speed(RPM)	Air flow(Q)	Pressure(P)	Noise(dBA)
产品编号	电压范围	额定电流	功率	转速	(CFM) 风量	(mmAq)风压	(In H <sub>2</sub> O) 噪音
RD8038B12L2	12(7~14)	0.25	3.00	6000	56.40	1.60	48.20
RD8038B12M2		0.50	6.00	8000	75.21	2.13	53.50
RD8038B12H2		0.95	11.40	10000	94.01	2.67	59.30
RD8038B12VH2		1.60	19.20	12500	117.51	3.33	62.80
RD8038B12SH2		2.70	32.40	15000	141.01	4.00	67.50
RD8038B12L2		24(15~27)	0.13	3.12	6000	56.40	1.60
RD8038B12M2	0.25		6.00	8000	75.21	2.13	53.50
RD8038B12H2	0.48		11.52	10000	94.01	2.67	59.30
RD8038B12VH2	0.80		19.20	12500	117.51	3.33	62.80
RD8038B12SH2	1.35		32.40	15000	141.01	4.00	67.50
RD8038B12L2	48(35~57)		0.07	3.36	6000	56.40	1.60
RD8038B12M2		0.13	6.24	8000	75.21	2.13	53.50
RD8038B12H2		0.24	11.52	10000	94.01	2.67	59.30
RD8038B12VH2		0.40	19.20	12500	117.51	3.33	62.80
RD8038B12SH2		0.68	32.64	15000	141.01	4.00	67.50

★ 如果您需要的转速或电压或功能不在这份清单上, 请与我们联系。  
If you want another rpm or voltage or functions which one is not in the list, please contact with our sales.

★ 提示1:功能的具体信息参照产品目录前页篇章。  
Notes1:The catalog have detail information in the front page for the functions.

★ 提示2:产品详细信息请参照承认书。  
Notes2:Product have a detail in the approval sheet.

★ 提示3:产品规格变更不另行通知。

# DC AXIAL FAN

## 80X80X56mm

### RD8056 Series



DIMENSIONS DRAWING

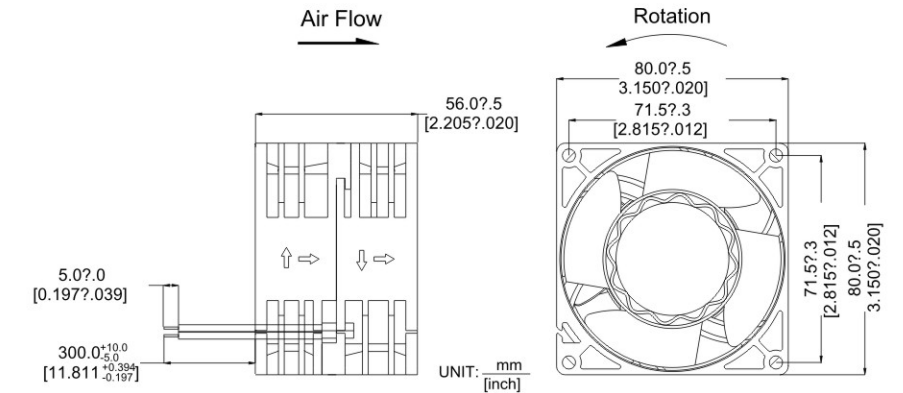

外框材质:环保防火PBT  
Frame:Thermoplastic PBT UL94-V0  
扇叶材质: 环保防火PBT  
Impeller:Thermoplastic PBT UL94-V0  
轴承结构: 双滚珠  
Bearing system:2Ball  
单体风扇重量:220g  
Unit Weight:220g

#### 可选的功能参照列表 (Available Functions)

1.马达保护(Motor protection)

RP	SS	AS	CL
●	●	●	●

2.信号输出(Signal output)

FG	RD	RD	LD
●	●	●	●

3.调速方式(Speed control mode)

PWM	TP	VC	RC	CS
●	●	●	●	●

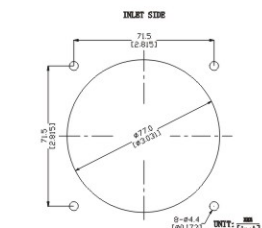
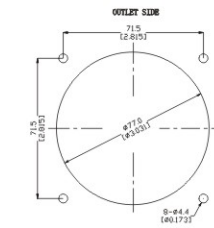
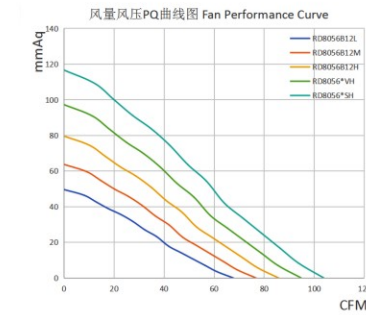

Part Number	Voltage(V)	Current(A)	Power(W)	Speed(RPM)	Air flow(Q)	Pressure(P)	Noise(dBA)
产品编号	电压范围	额定电流	功率	转速	(CFM) 风量	(mmAq)风压	(In H <sub>2</sub> O) 噪音
RD8056B12L	12(7~14)	1.14	13.68	15000	67.68	1.92	53.20
RD8056B12M		1.38	16.56	17000	76.71	2.18	57.46
RD8056B12H		1.62	19.44	19000	85.73	2.43	62.05
RD8056B12VH		2.00	24.00	21000	94.76	2.69	67.02
RD8056B12SH		2.43	29.16	23000	103.78	2.94	72.38
RD8056B24L		24(15~27)	0.57	13.68	15000	67.68	1.92
RD8056B24M	0.69		16.56	17000	76.71	2.18	57.46
RD8056B24H	0.81		19.44	19000	85.73	2.43	62.05
RD8056B24VH	1.00		24.00	21000	94.76	2.69	67.02
RD8056B24SH	1.22		29.28	23000	103.78	2.94	72.38
RD8056B48L	48(35~57)		0.29	13.92	15000	67.68	1.92
RD8056B48M		0.35	16.80	17000	76.71	2.18	57.46
RD8056B48H		0.41	19.68	19000	85.73	2.43	62.05
RD8056B48VH		0.50	24.00	21000	94.76	2.69	67.02
RD8056B48SH		0.61	29.28	23000	103.78	2.94	72.38

★ 如果您需要的转速或电压或功能不在这份清单上, 请与我们联系。  
If you want another rpm or voltage or functions which one is not in the list, please contact with our sales.

★ 提示1:功能的具体信息参照产品目录前页篇章。  
Notes1:The catalog have detail information in the front page for the functions.

★ 提示2:产品详细信息请参照承认书。  
Notes2:Product have a detail in the approval sheet.

★ 提示3:产品规格变更不另行通知。

## DC AXIAL FAN

### 90x90x15mm RS9015Series



外框材质:环保防火PBT  
Frame:Thermoplastic PBT UL94-V0  
扇叶材质:环保防火PBT  
Impeller:Thermoplastic PBT UL94-V0  
轴承结构:双滚珠或长寿命含油结构  
Bearing system:2Ball or Long life sleeve  
单体风扇重量:50g  
Unit Weight:50g

DIMENSIONS DRAWING

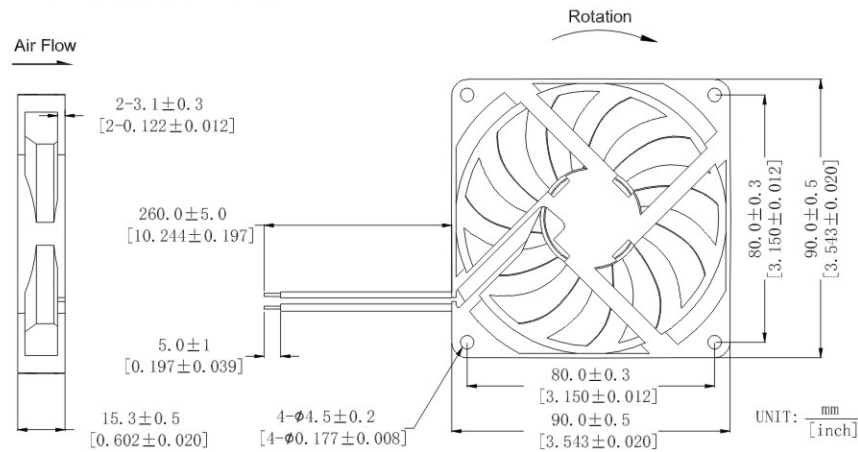

Fan Performance Curve

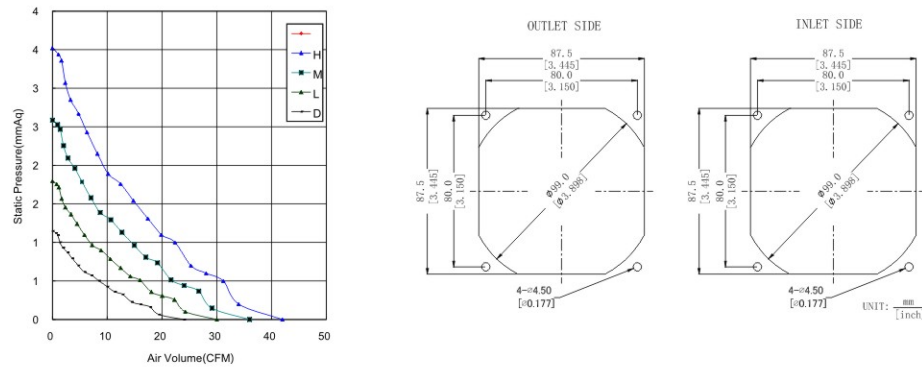

可选的功能参照列表  
(Available Functions)

1.马达保护(Motor protection)

RP	SS	AS	CL
●	●	●	●

2.信号输出(Signal output)

FG	RD	RD	LD
●	●	●	●

3.调速方式(Speed control mode)

PWM	TP	VC	RC	CS
●	●	●	●	●

Part Number	Voltage(V)	Current(A)	Power(W)	Speed(RPM)	Air flow(Q)	Pressure(P)	Noise(dBA)
产品编号	电压范围	额定电流	功率	转速	(CFM) 风量	m <sup>3</sup> /min (mmAq)风压 (In H <sub>2</sub> O)	噪音
RS9015x05D	5(4~6)	0.17	0.85	2000	23.99	0.68 1.15 0.05	27.6
RS9015x05L		0.24	1.20	2500	29.99	0.85 1.80 0.07	31.4
RS9015x12D	12(7~14)	0.07	0.84	2000	23.99	0.68 1.15 0.05	27.6
RS9015x12L		0.10	1.20	2500	29.99	0.85 1.80 0.07	31.4
RS9015x12M		0.17	2.04	3000	35.99	1.02 2.59 0.10	34.5
RS9015x12H		0.26	3.12	3500	41.99	1.19 3.52 0.14	37.5
RS9015x24M	24(15~27)	0.05	1.20	2500	29.99	0.85 1.80 0.07	31.4
RS9015x24H		0.08	1.92	3000	35.99	1.02 2.59 0.10	34.5
RS9015x24VH		0.13	3.12	3500	41.99	1.19 3.52 0.14	37.5

★ 如果您需要的转速或电压或功能不在这份清单上, 请与我们联系。  
If you want another rpm or voltage or functions which one is not in the list, please contact with our sales.

★ 提示1:功能的具体信息参照产品目录前页篇章。  
Notes1:The catalog have detail information in the front page for the functions.

★ 提示2:产品详细信息请参照承认书。  
Notes2:Product have a detail in the approval sheet.

★ 提示3:产品规格变更不另行通知。  
Notes3:Specifications are subject to change without notice.

★ 提示4:调速方式只能制作12V机型。  
Note4:Speed control mode only for 12V products.

## DC AXIAL FAN

### 92x92x25mm RS9225 Series



外框材质:环保防火PBT  
Frame:Thermoplastic PBT UL94-V0  
扇叶材质:环保防火PBT  
Impeller:Thermoplastic PBT UL94-V0  
轴承结构:双滚珠或长寿命含油结构  
Bearing system:2Ball or Long life sleeve  
单体风扇重量:78g  
Unit Weight:78g

DIMENSIONS DRAWING

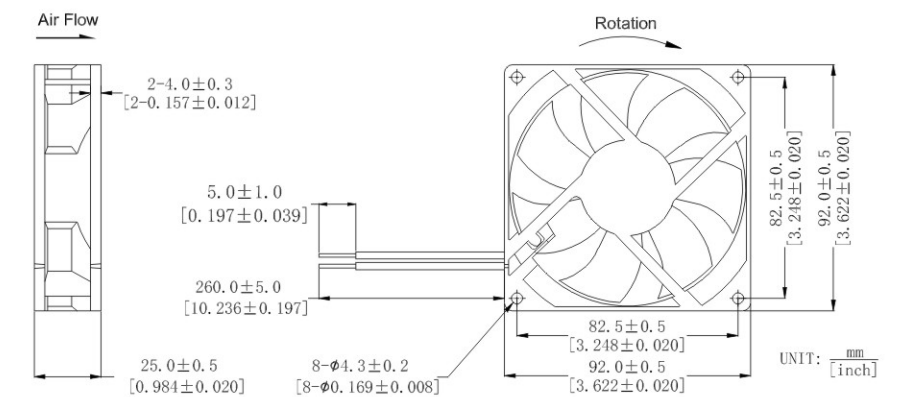

Fan Performance Curve

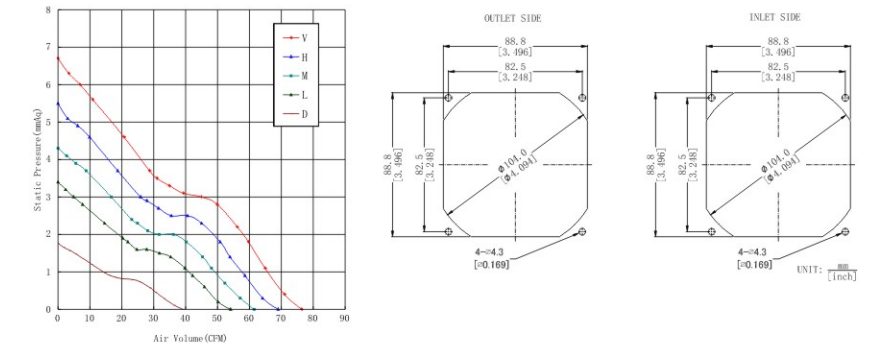

可选的功能参照列表  
(Available Functions)

1.马达保护(Motor protection)

RP	SS	AS	CL
●	●	●	●

2.信号输出(Signal output)

FG	RD	RD	LD
●	●	●	●

3.调速方式(Speed control mode)

PWM	TP	VC	RC	CS
●	●	●	●	●

Part Number	Voltage(V)	Current(A)	Power(W)	Speed(RPM)	Air flow(Q)	Pressure(P)	Noise(dBA)
产品编号	电压范围	额定电流	功率	转速	(CFM) 风量	m <sup>3</sup> /min (mmAq)风压 (In H <sub>2</sub> O)	噪音
RS9225x12D	12(7~14)	0.12	1.44	2000	39.14	1.10 1.76 0.07	30.3
RS9225x12L		0.20	2.4	2800	54.05	1.52 3.35 0.13	36.7
RS9225x12M		0.26	3.12	3200	61.51	1.74 4.34 0.17	39.1
RS9225x12H		0.30	3.6	3600	68.97	1.95 5.46 0.21	42.8
RS9225x12VH		0.44	5.28	4000	76.42	2.16 6.71 0.26	46.7
RS9225x24D	24(15~27)	0.06	1.44	2000	39.14	1.10 1.76 0.07	30.3
RS9225x24L		0.10	2.4	2800	54.05	1.52 3.35 0.13	36.7
RS9225x24M		0.13	3.12	3200	61.51	1.74 4.34 0.17	39.1
RS9225x24H		0.15	3.6	3600	68.97	1.95 5.46 0.21	42.8
RS9225x24VH		0.20	4.8	4000	76.42	2.16 6.71 0.26	46.7
RS9225x48M	48(35~57)	0.07	3.36	3200	61.51	1.74 4.34 0.17	39.1
RS9225x48H		0.08	3.84	3600	68.97	1.95 5.46 0.21	42.8
RS9225x48VH		0.10	4.8	4000	76.42	2.16 6.71 0.26	46.7

★ 如果您需要的转速或电压或功能不在这份清单上, 请与我们联系。  
If you want another rpm or voltage or functions which one is not in the list, please contact with our sales.

★ 提示1:功能的具体信息参照产品目录前页篇章。  
Notes1:The catalog have detail information in the front page for the functions.

★ 提示2:产品详细信息请参照承认书。  
Notes2:Product have a detail in the approval sheet.

★ 提示3:产品规格变更不另行通知。  
Notes3:Specifications are subject to change without notice.

## DC AXIAL FAN

### 92x92x25mm

#### RD9225 Series



外框材质:环保防火PBT  
Frame:Thermoplastic PBT UL94-V0  
扇叶材质:环保防火PBT  
Impeller:Thermoplastic PBT UL94-V0  
轴承结构:双滚珠或长寿命含油结构  
Bearing system:2Ball or Long life sleeve  
单体风扇重量:120g  
Unit Weight:120g

#### 可选的功能参照列表 (Available Functions)

1.马达保护(Motor protection)

RP	SS	AS	CL
●	●	●	●

2.信号输出(Signal output)

FG	RD	RD	LD
●	●	●	●

3.调速方式(Speed control mode)

PWM	TP	VC	RC	CS
●	●	●	●	●

#### DIMENSIONS DRAWING

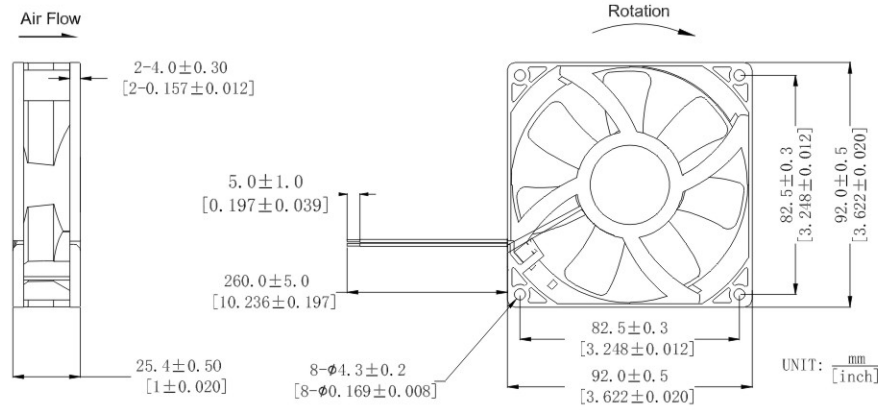

#### Fan Performance Curve

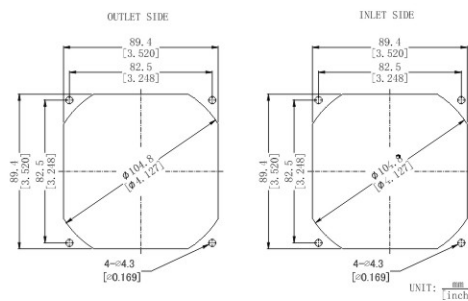
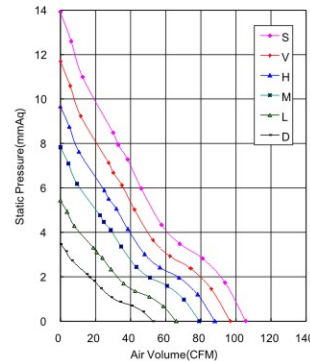

Part Number	Voltage(V)	Current(A)	Power(W)	Speed(RPM)	Air flow(Q)	Pressure(P)	Noise(dBA)
产品编号	电压范围	额定电流	功率	转速	(CFM) 风量	m <sup>3</sup> /min (mmAq)风压 (In H <sub>2</sub> O)	噪音
RD9225x12D	12(7~14)	0.12	1.44	2400	52.76	1.49 3.48	0.14 35.0
RD9225x12L		0.21	2.52	3000	65.95	1.87 5.44	0.21 40.9
RD9225x12M		0.38	4.56	3600	79.14	2.24 7.83	0.31 45.1
RD9225x12H		0.5	6	4000	87.94	2.49 9.67	0.38 48.0
RD9225x12VH		0.62	7.44	4400	96.73	2.74 11.70	0.46 50.8
RD9225x12SH	0.84	10.08	4800	105.52	2.99 13.92	0.55 53.0	
RD9225x24D	24(15~27)	0.06	1.44	2400	52.76	1.49 3.48	0.14 35.0
RD9225x24L		0.11	2.64	3000	65.95	1.87 5.44	0.21 40.9
RD9225x24M		0.19	4.56	3600	79.14	2.24 7.83	0.31 45.1
RD9225x24H		0.25	6	4000	87.94	2.49 9.67	0.38 48.0
RD9225x24VH		0.31	7.44	4400	96.73	2.74 11.70	0.46 50.8
RD9225x24SH	0.42	10.08	4800	105.52	2.99 13.92	0.55 53.0	
RD9225x48L	48(35~57)	0.05	2.4	3000	65.95	1.87 5.44	0.21 40.9
RD9225x48M		0.1	4.8	3600	79.14	2.24 7.83	0.31 45.1
RD9225x48H		0.13	6.24	4000	87.94	2.49 9.67	0.38 48.0
RD9225x48VH		0.16	7.68	4400	96.73	2.74 11.70	0.46 50.8
RD9225x48SH		0.21	10.08	4800	105.52	2.99 13.92	0.55 53.0

★ 如果您需要的转速或电压或功能不在这份清单上, 请与我们联系。  
If you want another rpm or voltage or functions which one is not in the list, please contact with our sales.

★ 提示1:功能的具体信息参照产品目录前页篇章。  
Notes1:The catalog have detail information in the front page for the functions.

★ 提示2:产品详细信息请参照承认书。  
Notes2:Product have a detail in the approval sheet.

★ 提示3:产品规格变更不另行通知。  
Notes3:Specifications are subject to change without notice.

## DC AXIAL FAN

### 92x92x28mm

#### RD9228 Series



外框材质:环保防火PBT  
Frame:Thermoplastic PBT UL94-V0  
扇叶材质:环保防火PBT  
Impeller:Thermoplastic PBT UL94-V0  
轴承结构:双滚珠或长寿命含油结构  
Bearing system:2Ball or Long life sleeve  
单体风扇重量:120g  
Unit Weight:120g

#### 可选的功能参照列表 (Available Functions)

1.马达保护(Motor protection)

RP	SS	AS	CL
●	●	●	●

2.信号输出(Signal output)

FG	RD	RD	LD
●	●	●	●

3.调速方式(Speed control mode)

PWM	TP	VC	RC	CS
●	●	●	●	●

#### DIMENSIONS DRAWING

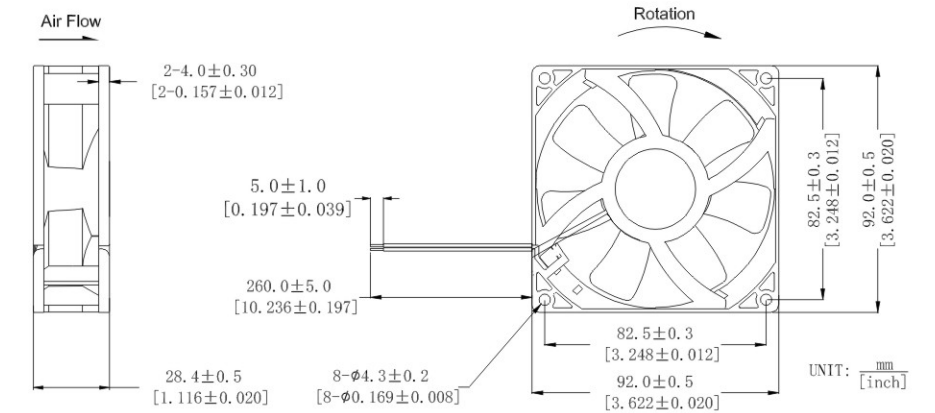

#### Fan Performance Curve

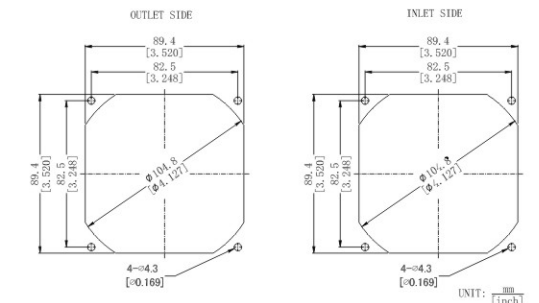
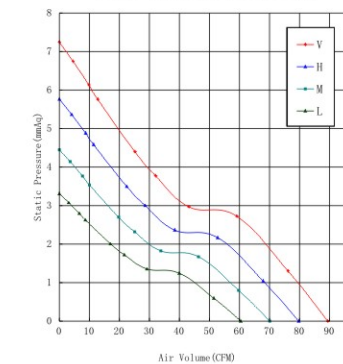

Part Number	Voltage(V)	Current(A)	Power(W)	Speed(RPM)	Air flow(Q)	Pressure(P)	Noise(dBA)
产品编号	电压范围	额定电流	功率	转速	(CFM) 风量	m <sup>3</sup> /min (mmAq)风压 (In H <sub>2</sub> O)	噪音
RD9228x12L	12(7~14)	0.16	1.92	2400	58.00	1.64 3.05	0.12 34.4
RD9228x12M		0.25	3.00	2800	67.67	1.91 4.15	0.16 38.0
RD9228x12H		0.41	4.92	3200	77.33	2.19 5.42	0.21 41.6
RD9228x12VH		0.54	6.48	3600	87.00	2.46 6.86	0.27 44.8
RD9228x24L	24(15~27)	0.08	1.92	2400	58.00	1.64 3.05	0.12 34.4
RD9228x24M		0.12	2.88	2800	67.67	1.91 4.15	0.16 38.0
RD9228x24H		0.2	4.80	3200	77.33	2.19 5.42	0.21 41.6
RD9228x24VH		0.27	6.48	3600	87.00	2.46 6.86	0.27 44.8

★ 如果您需要的转速或电压或功能不在这份清单上, 请与我们联系。  
If you want another rpm or voltage or functions which one is not in the list, please contact with our sales.

★ 提示1:功能的具体信息参照产品目录前页篇章。  
Notes1:The catalog have detail information in the front page for the functions.

★ 提示2:产品详细信息请参照承认书。  
Notes2:Product have a detail in the approval sheet.

★ 提示3:产品规格变更不另行通知。  
Notes3:Specifications are subject to change without notice.

## DC AXIAL FAN

### 92x92x32mm RD9232 Series



外框材质:环保防火PBT  
Frame:Thermoplastic PBT UL94-V0  
扇叶材质:环保防火PBT  
Impeller:Thermoplastic PBT UL94-V0  
轴承结构:双滚珠或长寿命含油结构  
Bearing system:2Ball or Long life sleeve  
单体风扇重量:150g  
Unit Weight:150g

DIMENSIONS DRAWING

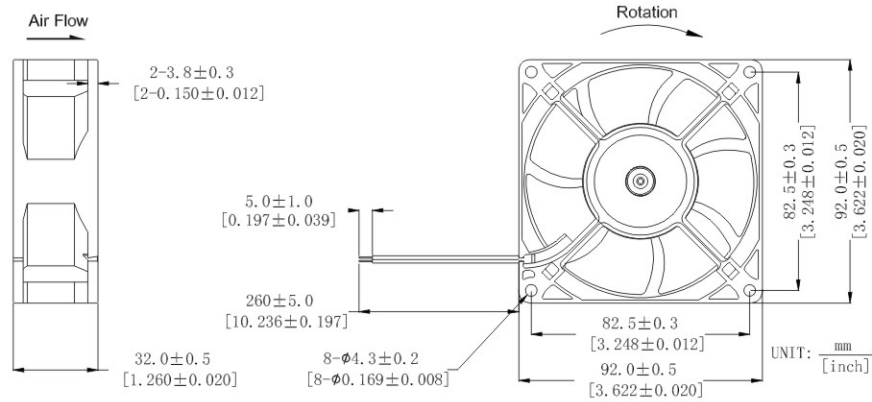

Fan Performance Curve

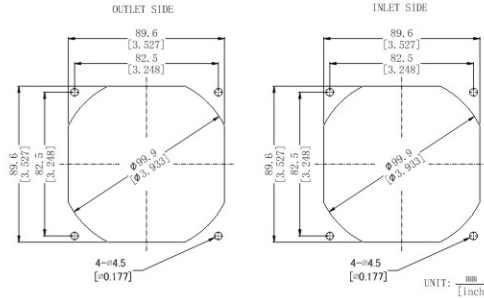
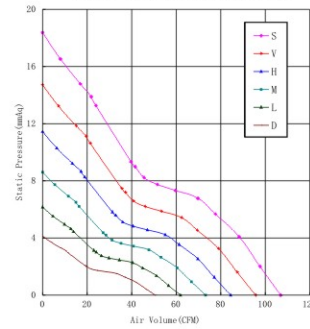

可选的功能参照列表  
(Available Functions)

1.马达保护(Motor protection)

RP	SS	AS	CL
●	●	●	●

2.信号输出(Signal output)

FG	RD	RD	LD
●	●	●	●

3.调速方式(Speed control mode)

PWM	TP	VC	RC	CS
●	●	●	●	●

Part Number	Voltage(V)	Current(A)	Power(W)	Speed(RPM)	Air flow(Q)	Pressure(P)	Noise(dBA)		
产品编号	电压范围	额定电流	功率	转速	(CFM) 风量	m <sup>3</sup> /min	(mmAq)风压 (In H <sub>2</sub> O)	噪音	
RD9232X12D	12(7~14)	0.22	2.64	2600	50.67	1.43	4.13	0.16	38.0
RD9232X12L		0.31	3.72	3200	61.92	1.75	6.16	0.24	43.0
RD9232X12M		0.46	5.52	3800	73.18	2.07	8.61	0.34	48.8
RD9232X12H		0.60	7.20	4400	84.45	2.39	11.46	0.45	49.7
RD9232X12VH		0.98	11.76	5000	95.70	2.71	14.72	0.58	52.8
RD9232X12SH		1.10	26.40	5600	106.96	3.03	18.39	0.72	57.2
RD9232X24D	24(15~27)	0.11	2.64	2600	50.67	1.43	4.13	0.16	38.0
RD9232X24L		0.16	3.84	3200	61.92	1.75	6.16	0.24	43.0
RD9232X24M		0.23	5.52	3800	73.18	2.07	8.61	0.34	48.8
RD9232X24H		0.30	7.20	4400	84.45	2.39	11.46	0.45	49.7
RD9232X24VH		0.49	11.76	5000	95.70	2.71	14.72	0.58	52.8
RD9232X24SH		0.55	13.20	5600	106.96	3.03	18.39	0.72	57.2
RD9232X48D	48(35~57)	0.06	2.88	2600	50.67	1.43	4.13	0.16	38.0
RD9232X48L		0.08	3.84	3200	61.92	1.75	6.16	0.24	43.0
RD9232X48M		0.11	5.28	3800	73.18	2.07	8.61	0.34	48.8
RD9232X48H		0.15	7.20	4400	84.45	2.39	11.46	0.45	49.7
RD9232X48VH		0.24	11.52	5000	95.70	2.71	14.72	0.58	52.8
RD9232X48SH		0.28	13.44	5600	106.96	3.03	18.39	0.72	57.2

★ 如果您需要的转速或电压或功能不在这份清单上, 请与我们联系。  
If you want another rpm or voltage or functions which one is not in the list, please contact with our sales.

★ 提示1:功能的具体信息参照产品目录前页篇章。  
Notes1:The catalog have detail information in the front page for the functions.

★ 提示2:产品详细信息请参照承认书。  
Notes2:Product have a detail in the approval sheet.

★ 提示3:产品规格变更不另行通知。  
Notes3:Specifications are subject to change without notice.

## DC AXIAL FAN

### 92x92x38mm RD9238 Series



外框材质:环保防火PBT  
Frame:Thermoplastic PBT UL94-V0  
扇叶材质:环保防火PBT  
Impeller:Thermoplastic PBT UL94-V0  
轴承结构:双滚珠或长寿命含油结构  
Bearing system:2Ball or Long life sleeve  
单体风扇重量:198g  
Unit Weight:198g

DIMENSIONS DRAWING

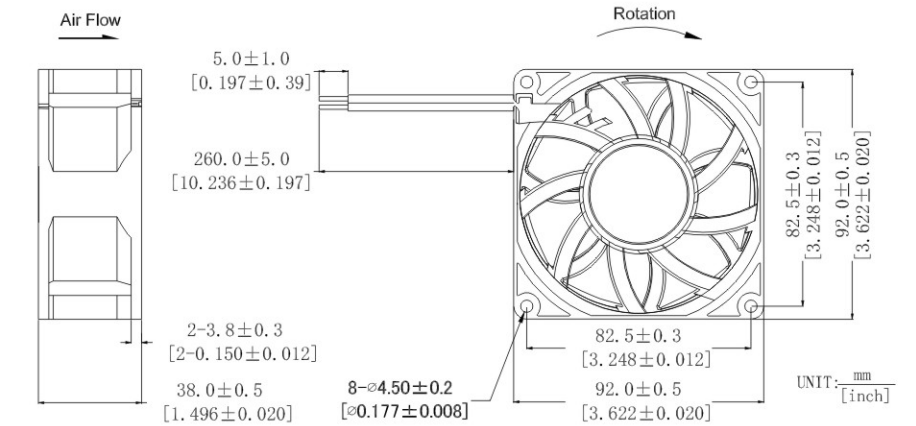

Fan Performance Curve

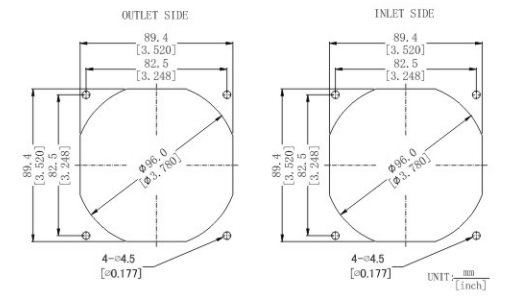
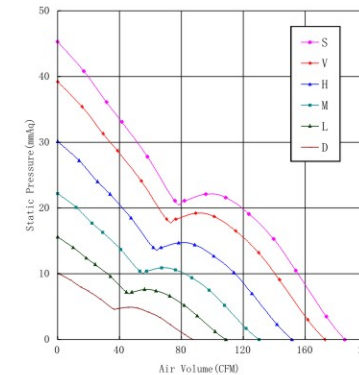

可选的功能参照列表  
(Available Functions)

1.马达保护(Motor protection)

RP	SS	AS	CL
●	●	●	●

2.信号输出(Signal output)

FG	RD	RD	LD
●	●	●	●

3.调速方式(Speed control mode)

PWM	TP	VC	RC	CS
●	●	●	●	●

Part Number	Voltage(V)	Current(A)	Power(W)	Speed(RPM)	Air flow(Q)	Pressure(P)	Noise(dBA)		
产品编号	电压范围	额定电流	功率	转速	(CFM) 风量	m <sup>3</sup> /min	(mmAq)风压 (In H <sub>2</sub> O)	噪音	
RD9238X12D	12(7~14)	0.42	5.04	4000	87.48	2.47	10.05	0.40	45.30
RD9238X12L		0.82	9.84	5000	108.81	3.08	15.55	0.61	50.50
RD9238X12M		1.16	13.92	6000	130.15	3.68	22.24	0.88	55.40
RD9238X12H		1.60	19.20	7000	151.49	4.29	30.13	1.19	58.80
RD9238X12VH		2.30	27.60	8000	172.82	4.89	39.22	1.54	63.30
RD9238X24D		24(15~27)	0.21	5.04	4000	87.48	2.47	10.05	0.40
RD9238X24L	0.41		9.84	5000	108.81	3.08	15.55	0.61	50.50
RD9238X24M	0.58		13.92	6000	130.15	3.68	22.24	0.88	55.40
RD9238X24H	0.80		19.20	7000	151.49	4.29	30.13	1.19	58.80
RD9238X24VH	1.15		27.60	8000	172.82	4.89	39.22	1.54	63.30
RD9238X24SH	1.36		32.64	8500	183.49	5.19	44.21	1.74	64.80
RD9238X48D	48(35~57)	0.10	4.80	4000	87.48	2.47	10.05	0.40	45.30
RD9238X48L		0.20	9.60	5000	108.81	3.08	15.55	0.61	50.50
RD9238X48M		0.26	12.48	6000	130.15	3.68	22.24	0.88	55.40
RD9238X48H		0.40	19.20	7000	151.49	4.29	30.13	1.19	58.80
RD9238X48VH		0.58	27.84	8000	172.82	4.89	39.22	1.54	63.30
RD9238X48SH		0.68	32.64	8500	183.49	5.19	44.21	1.74	64.80

★ 如果您需要的转速或电压或功能不在这份清单上, 请与我们联系。  
If you want another rpm or voltage or functions which one is not in the list, please contact with our sales.

★ 提示1:功能的具体信息参照产品目录前页篇章。  
Notes1:The catalog have detail information in the front page for the functions.

★ 提示2:产品详细信息请参照承认书。  
Notes2:Product have a detail in the approval sheet.

★ 提示3:产品规格变更不另行通知。  
Notes3:Specifications are subject to change without notice.

## DC AXIAL FAN

### 92x92x38mm

RD 9238AJ



外框材质:环保防火PBT  
Frame:Thermoplastic PBT UL94-V0  
扇叶材质: 环保防火PBT  
Impeller:Thermoplastic PBT UL94-V0  
轴承结构: 双滚珠  
Bearing system:2Ball  
单体风扇重量:194g  
Unit Weight:194g

DIMENSIONS DRAWING

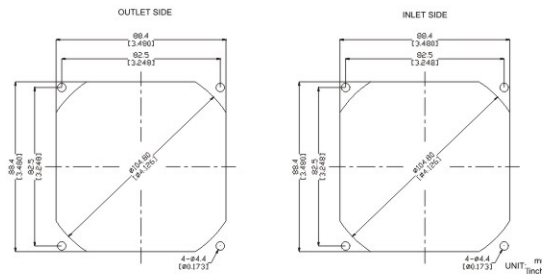
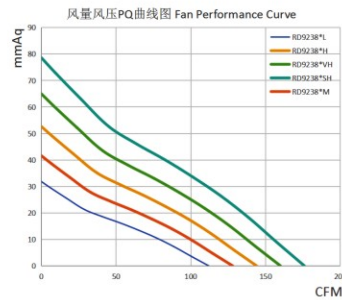
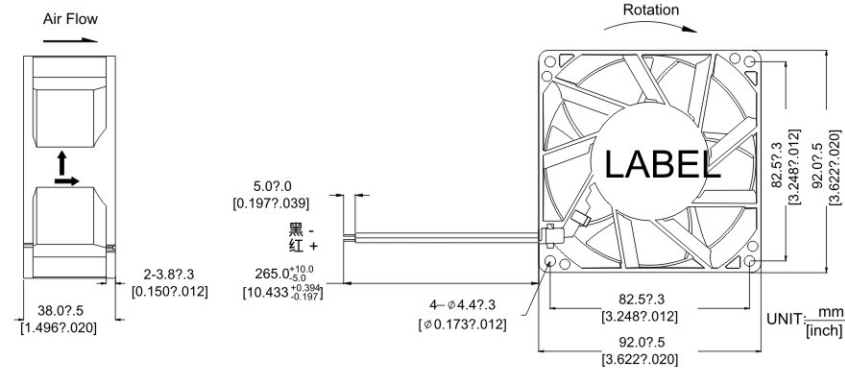

#### 可选的功能参照列表 (Available Functions)

1. 马达保护(Motor protection)

RP	SS	AS	CL
<input type="checkbox"/>	<input type="checkbox"/>	<input type="checkbox"/>	<input type="checkbox"/>

2. 信号输出(Signal output)

FG	RD	RD	LD
<input type="checkbox"/>	<input type="checkbox"/>	<input type="checkbox"/>	<input type="checkbox"/>

3. 调速方式(Speed control mode)

PWM	TP	VC	RC	CS
<input type="checkbox"/>	<input type="checkbox"/>	<input type="checkbox"/>	<input type="checkbox"/>	<input type="checkbox"/>

Part Number	Voltage(V)	Current(A)	Power(W)	Speed(RPM)	Air flow(Q)	Pressure(P)	Noise(dBA)
产品编号	电压范围	额定电流	功率	转速	(CFM) 风量	(mmAq)风压	(In H <sub>2</sub> O) 噪音
RD9238B12L2	12(7~14)	0.82	9.84	7000	111.97	3.18	54.23
RD9238B12M2		1.19	14.28	8000	127.96	3.63	58.25
RD9238B12H2		1.57	18.84	9000	143.99	4.08	61.44
RD9238B12VH2		2.10	25.20	10000	159.95	4.54	64.23
RD9238B12SH2		2.72	32.64	11000	175.95	4.99	66.99
RD9238B24L2	24(15~27)	0.41	9.84	7000	111.97	3.18	54.23
RD9238B24M2		0.60	14.40	8000	127.96	3.63	58.25
RD9238B24H2		0.79	18.96	9000	143.99	4.08	61.44
RD9238B24VH2		1.05	25.20	10000	159.95	4.54	64.23
RD9238B24SH2		1.36	32.64	11000	175.95	4.99	66.99
RD9238B48L2	48(35~57)	0.21	10.08	7000	111.97	3.18	54.23
RD9238B48M2		0.30	14.40	8000	127.96	3.63	58.25
RD9238B48H2		0.40	19.20	9000	143.99	4.08	61.44
RD9238B48VH2		0.53	25.44	10000	159.95	4.54	64.23
RD9238B48SH2		0.68	32.64	11000	175.95	4.99	66.99

★ 如果您需要的转速或电压或功能不在这份清单上, 请与我们联系。  
If you want another rpm or voltage or functions which one is not in the list, please contact with our sales.

★ 提示1:功能的具体信息参照产品目录前页篇章。  
Notes1:The catalog have detail information in the front page for the functions.

★ 提示2:产品详细信息请参照承认书。  
Notes2:Product have a detail in the approval sheet.

★ 提示3:产品规格变更不另行通知。  
Notes3:Specifications are subject to change without notice.

## DC AXIAL FAN

### 120x120x25mm

RS1225 Series



外框材质:环保防火PBT  
Frame:Thermoplastic PBT UL94-V0  
扇叶材质:环保防火PBT  
Impeller:Thermoplastic PBT UL94-V0  
轴承结构:双滚珠或长寿命含油结构  
Bearing system:2Ball or Long life sleeve  
单体风扇重量:125g  
Unit Weight:125g

DIMENSIONS DRAWING

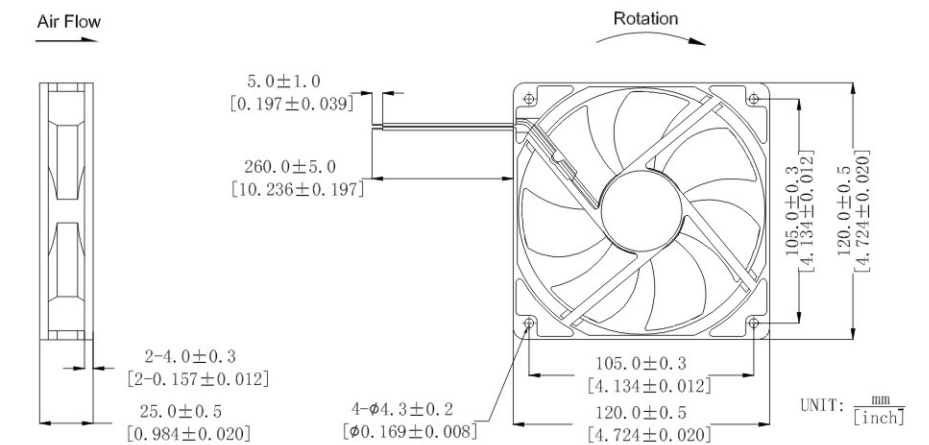

#### 可选的功能参照列表 (Available Functions)

1. 马达保护(Motor protection)

RP	SS	AS	CL
<input type="checkbox"/>	<input type="checkbox"/>	<input type="checkbox"/>	<input type="checkbox"/>

2. 信号输出(Signal output)

FG	RD	RD	LD
<input type="checkbox"/>	<input type="checkbox"/>	<input type="checkbox"/>	<input type="checkbox"/>

3. 调速方式(Speed control mode)

PWM	TP	VC	RC	CS
<input type="checkbox"/>	<input type="checkbox"/>	<input type="checkbox"/>	<input type="checkbox"/>	<input type="checkbox"/>

Fan Performance Curve

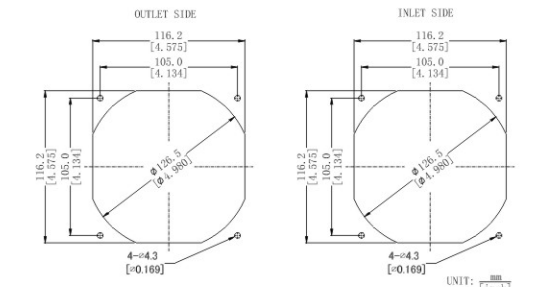
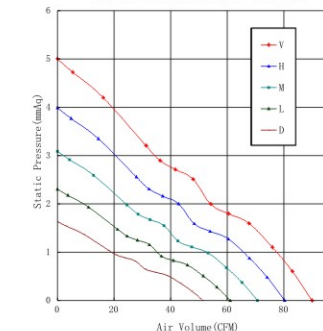

Part Number	Voltage(V)	Current(A)	Power(W)	Speed(RPM)	Air flow(Q)	Pressure(P)	Noise(dBA)
产品编号	电压范围	额定电流	功率	转速	(CFM) 风量	(mmAq)风压	(In H <sub>2</sub> O) 噪音
RS1225X12D	12(7~14)	0.12	1.44	1500	51.39	1.45	27.0
RS1225X12L		0.16	1.92	1800	61.03	1.73	32.2
RS1225X12M		0.23	2.76	2100	70.69	2.00	35.5
RS1225X12H		0.30	3.6	2400	80.31	2.27	39.0
RS1225X12VH		0.38	4.56	2700	89.94	2.54	42.3
RS1225X24D	24(15~27)	0.06	1.44	1500	51.39	1.45	27.0
RS1225X24L		0.08	1.92	1800	61.03	1.73	32.2
RS1225X24M		0.12	2.88	2100	70.69	2.00	35.5
RS1225X24H		0.15	3.6	2400	80.31	2.27	39.0
RS1225X24VH		0.19	4.56	2700	89.94	2.54	42.3

★ 如果您需要的转速或电压或功能不在这份清单上, 请与我们联系。  
If you want another rpm or voltage or functions which one is not in the list, please contact with our sales.

★ 提示1:功能的具体信息参照产品目录前页篇章。  
Notes1:The catalog have detail information in the front page for the functions.

★ 提示2:产品详细信息请参照承认书。  
Notes2:Product have a detail in the approval sheet.

★ 提示3:产品规格变更不另行通知。  
Notes3:Specifications are subject to change without notice.

## DC AXIAL FAN

### 120x120x25mm

#### RD1225 Series



外框材质:环保防火PBT  
Frame:Thermoplastic PBT UL94-V0  
扇叶材质:环保防火PBT  
Imperller:Thermoplastic PBT UL94-V0  
轴承结构:双滚珠或长寿命含油结构  
Bearing system:2Ball or Long life sleeve  
单体风扇重量:125g  
Unit Weight:125g

#### 可选的功能参照列表 (Available Functions)

1.马达保护(Motor protection)

RP	SS	AS	CL
●	●	●	●

2.信号输出(Signal output)

FG	RD	RD	LD
●	●	●	●

3.调速方式(Speed control mode)

PWM	TP	VC	RC	CS
●	●	●	●	●

#### DIMENSIONS DRAWING

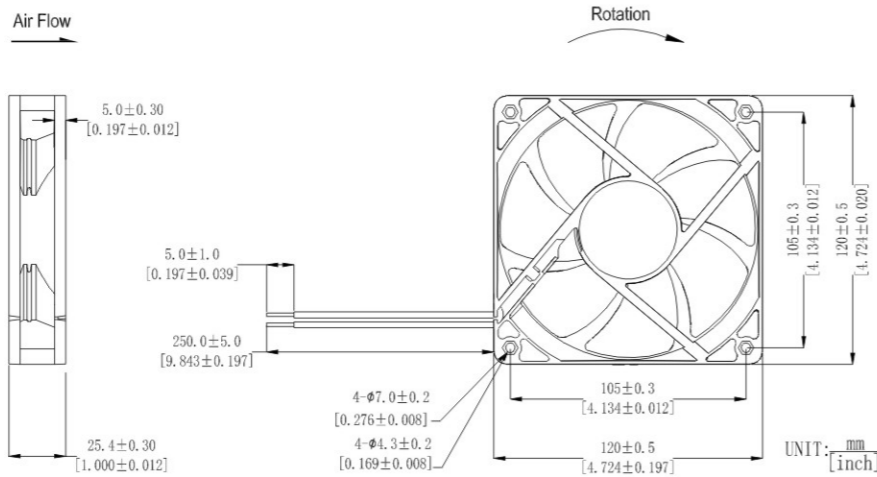

#### Fan Performance Curve

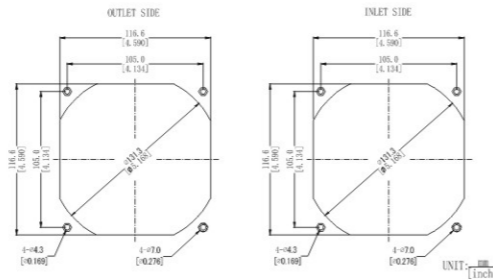
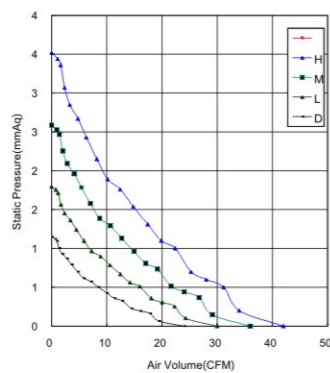

Part Number	Voltage(V)	Current(A)	Power(W)	Speed(RPM)	Air flow(Q)	Pressure(P)	Noise(dBA)
产品编号	电压范围	额定电流	功率	转速	(CFM) 风量	m <sup>3</sup> /min (mmAq)风压 (In H <sub>2</sub> O)	噪音
RD1225x12D	12(7~14)	0.28	3.36	3000	85.59	2.42	43.6
RD1225x12L		0.40	4.80	3500	99.85	2.83	48.2
RD1225x12M		0.62	7.44	4000	114.12	3.23	50.6
RD1225x12H		0.76	9.12	4500	128.38	3.63	53.6
RD1225x12VH		1.2	14.4	5000	150.71	4.26	56.6
RD1225x12SH		1.32	15.84	5500	165.48	4.68	59.0
RD1225x24D	24(15~27)	0.16	3.84	3000	85.59	2.42	43.6
RD1225x24L		0.38	9.12	4000	114.12	3.23	50.6
RD1225x24M		0.41	9.84	4500	128.38	3.63	53.6
RD1225x24H		0.6	14.4	5000	150.71	4.26	56.6
RD1225x24VH		0.66	15.84	5500	165.48	4.68	59.0
RD1225x24SH		0.66	15.84	5500	165.48	4.68	59.0
RD1225x48L	48(35~57)	0.10	4.80	3500	99.85	2.83	48.2
RD1225x48M		0.16	7.68	4000	114.12	3.23	50.6
RD1225x48H		0.23	11.04	4500	128.38	3.63	53.6
RD1225x48M		0.19	9.12	4000	121.16	3.43	50.5
RD1225x48H		0.21	10.08	4500	135.93	3.85	53.8
RD1225x48VH		0.3	14.4	5000	150.71	4.26	56.6
RD1225x48SH	0.33	15.84	5500	165.48	4.68	59.0	

★ 如果您需要的转速或电压或功能不在这份清单上, 请与我们联系。  
If you want another rpm or voltage or functions which one is not in the list, please contact with our sales.

★ 提示1:功能的具体信息参照产品目录前页篇章。  
Notes1:The catalog have detail information in the front page for the functions.

★ 提示2:产品详细信息请参照承认书。  
Notes2:Product have a detail in the approval sheet.

★ 提示3:产品规格变更不另行通知。  
Notes3:Specifications are subject to change without notice.

## DC AXIAL FAN

### 120x120x25mm

#### RD1225 Series



外框材质:环保防火PBT  
Frame:Thermoplastic PBT UL94-V0  
扇叶材质:环保防火PBT  
Imperller:Thermoplastic PBT UL94-V0  
轴承结构:双滚珠或长寿命含油结构  
Bearing system:2Ball or Long life sleeve  
单体风扇重量:125g  
Unit Weight:125g

#### 可选的功能参照列表 (Available Functions)

1.马达保护(Motor protection)

RP	SS	AS	CL
●	●	●	●

2.信号输出(Signal output)

FG	RD	RD	LD
●	●	●	●

3.调速方式(Speed control mode)

PWM	TP	VC	RC	CS
●	●	●	●	●

#### DIMENSIONS DRAWING

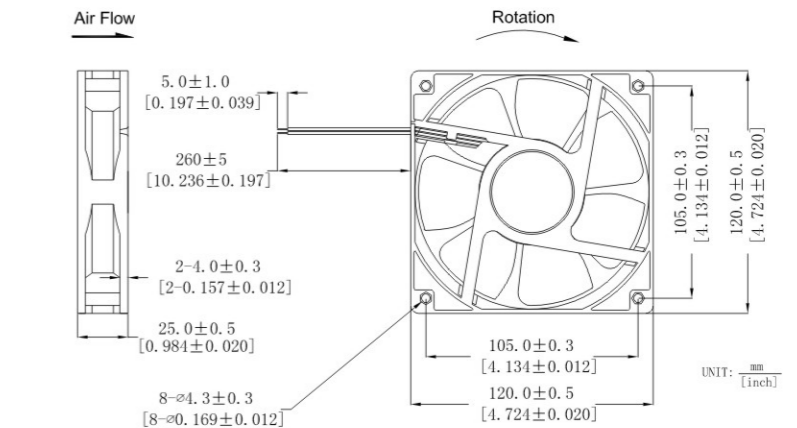

#### Fan Performance Curve

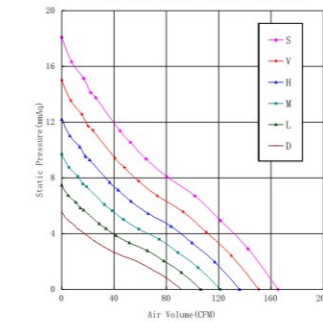

#### OUTLET SIDE

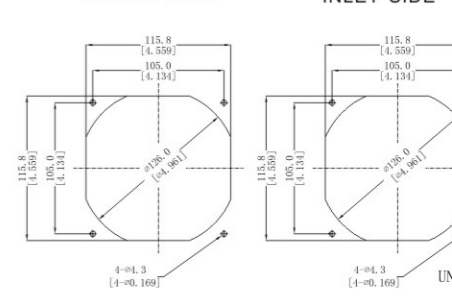

Part Number	Voltage(V)	Current(A)	Power(W)	Speed(RPM)	Air flow(Q)	Pressure(P)	Noise(dBA)
产品编号	电压范围	额定电流	功率	转速	(CFM) 风量	m <sup>3</sup> /min (mmAq)风压 (In H <sub>2</sub> O)	噪音
RD1225X12D	12(7~14)	0.32	3.84	3000	91.60	2.59	44.2
RD1225X12L		0.6	7.2	3500	106.38	3.01	47.2
RD1225X12M		0.76	9.12	4000	121.16	3.43	50.5
RD1225X12H		0.82	9.84	4500	135.93	3.85	53.8
RD1225X12VH		1.2	14.4	5000	150.71	4.26	56.6
RD1225X12SH		1.32	15.84	5500	165.48	4.68	59.0
RD1225X24D	24(15~27)	0.16	3.84	3000	85.59	2.59	44.2
RD1225X24L		0.3	7.2	3500	106.38	3.01	47.2
RD1225X24M		0.38	9.12	4000	121.16	3.43	50.5
RD1225X24H		0.41	9.84	4500	135.93	3.85	53.8
RD1225X24VH		0.6	14.4	5000	150.71	4.26	56.6
RD1225X24SH		0.66	15.84	5500	165.48	4.68	59.0
RD1225X48D	48(35~57)	0.08	3.84	3000	91.60	2.59	44.2
RD1225X48L		0.15	7.2	3500	106.38	3.01	47.2
RD1225X48M		0.19	9.12	4000	121.16	3.43	50.5
RD1225X48H		0.21	10.08	4500	135.93	3.85	53.8
RD1225X48VH		0.3	14.4	5000	150.71	4.26	56.6
RD1225X48SH		0.33	15.84	5500	165.48	4.68	59.0

★ 如果您需要的转速或电压或功能不在这份清单上, 请与我们联系。  
If you want another rpm or voltage or functions which one is not in the list, please contact with our sales.

★ 提示1:功能的具体信息参照产品目录前页篇章。  
Notes1:The catalog have detail information in the front page for the functions.

★ 提示2:产品详细信息请参照承认书。  
Notes2:Product have a detail in the approval sheet.

★ 提示3:产品规格变更不另行通知。  
Notes3:Specifications are subject to change without notice.

## DC AXIAL FAN

### 120x120x25mm

#### RD 1225C Series



外框材质:环保防火PBT  
Frame:Thermoplastic PBT UL94-V0  
扇叶材质: 环保防火PBT  
Impeller:Thermoplastic PBT UL94-V0  
轴承结构: 双滚珠  
Bearing system:2Ball  
单体风扇重量:186g  
Unit Weight:186g

DIMENSIONS DRAWING

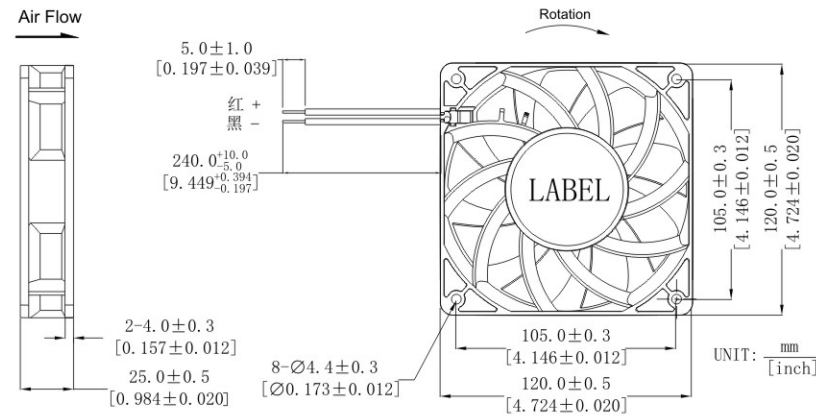

#### 可选的功能参照列表 (Available Functions)

1.马达保护(Motor protection)

RP	SS	AS	CL
●	●	●	●

2.信号输出(Signal output)

FG	RD	RD	LD
●	●	●	●

3.调速方式(Speed control mode)

PWM	TP	VC	RC	CS
●	●	●	●	●

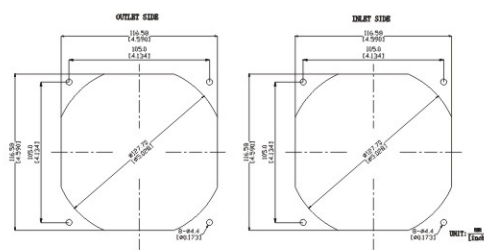
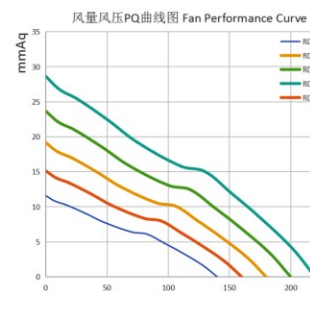

Part Number	Voltage(V)	Current(A)	Power(W)	Speed(RPM)	Air flow(Q)	Pressure(P)	Noise(dBA)		
产品编号	电压范围	额定电流	功率	转速	(CFM) 风量	m <sup>3</sup> /min (mmAq)风压 (In H <sub>2</sub> O)	噪音		
RD1225B12L2	12(7~14)	0.75	9.00	3500	139.91	3.97	11.59	0.46	13.71
RD1225B12M2		1.12	13.44	4000	159.89	4.54	15.14	0.60	46.50
RD1225B12H2		1.72	20.64	4500	179.88	5.10	19.17	0.75	49.29
RD1225B12VH2		2.63	31.56	5000	199.87	5.67	23.66	0.93	52.25
RD1225B12SH2		3.50	42.00	5500	219.86	6.24	28.63	1.13	55.38
RD1225B24L2		24(15~27)	0.38	9.12	3500	139.91	3.97	11.59	0.46
RD1225B24M2	0.56		13.44	4000	159.89	4.54	15.14	0.60	46.50
RD1225B24H2	0.86		20.64	4500	179.88	5.10	19.17	0.75	49.29
RD1225B24VH2	1.32		31.68	5000	199.87	5.67	23.66	0.93	52.25
RD1225B24SH2	1.75		42.00	5500	219.86	6.24	28.63	1.13	55.38
RD1225B48L2	48(35~57)		0.19	9.12	3500	139.91	3.97	11.59	0.46
RD1225B48M2		0.28	13.44	4000	159.89	4.54	15.14	0.60	46.50
RD1225B48H2		0.43	20.64	4500	179.88	5.10	19.17	0.75	49.29
RD1225B48VH2		0.66	31.68	5000	199.87	5.67	23.66	0.93	52.25
RD1225B48SH2		0.88	42.24	5500	219.86	6.24	28.63	1.13	55.38

★ 如果您需要的转速或电压或功能不在这份清单上, 请与我们联系。  
If you want another rpm or voltage or functions which one is not in the list, please contact with our sales.

★ 提示1:功能的具体信息参照产品目录前页篇章。  
Notes1:The catalog have detail information in the front page for the functions.

★ 提示2:产品详细信息请参照承认书。  
Notes2:Product have a detail in the approval sheet.

★ 提示3:产品规格变更不另行通知。  
Notes3:Specifications are subject to change without notice.

## DC AXIAL FAN

### 120x120x32mm

#### RS1232 Series



外框材质:环保防火PBT  
Frame:Thermoplastic PBT UL94-V0  
扇叶材质:环保防火PBT  
Impeller:Thermoplastic PBT UL94-V0  
轴承结构:双滚珠或长寿命含油结构  
Bearing system:2Ball or Long life sleeve  
单体风扇重量:220g  
Unit Weight:220g

DIMENSIONS DRAWING

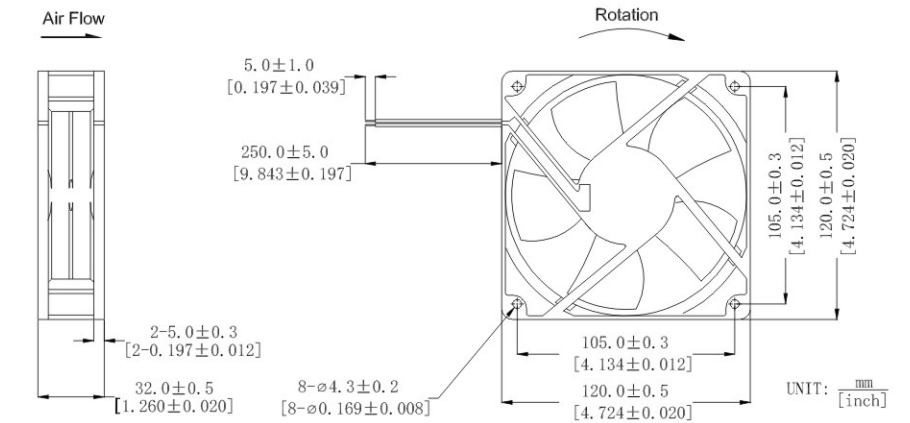

#### 可选的功能参照列表 (Available Functions)

1.马达保护(Motor protection)

RP	SS	AS	CL
●	●	●	●

2.信号输出(Signal output)

FG	RD	RD	LD
●	●	●	●

3.调速方式(Speed control mode)

PWM	TP	VC	RC	CS
●	●	●	●	●

Fan Performance Curve

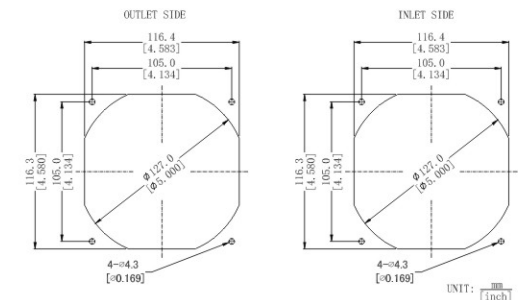
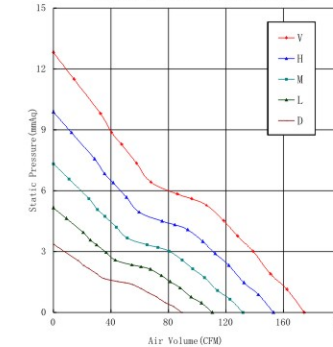

Part Number	Voltage(V)	Current(A)	Power(W)	Speed(RPM)	Air flow(Q)	Pressure(P)	Noise(dBA)		
产品编号	电压范围	额定电流	功率	转速	(CFM) 风量	m <sup>3</sup> /min (mmAq)风压 (In H <sub>2</sub> O)	噪音		
RS1232x12D	12(7~14)	0.14	1.68	2000	89.28	2.53	3.36	0.13	37.0
RS1232x12L		0.32	3.84	2500	110.54	3.13	5.15	0.20	42.6
RS1232x12M		0.76	9.12	3000	131.80	3.73	7.32	0.29	48.1
RS1232x12H		0.90	10.8	3500	153.06	4.33	9.88	0.39	51.0
RS1232x12VH		1.02	12.24	4000	174.32	4.93	11.81	0.46	54.5
RS1232x24D		24(15~27)	0.07	1.68	2000	89.28	2.53	3.36	0.13
RS1232x24L	0.16		3.84	2500	110.54	3.13	5.15	0.20	42.6
RS1232x24M	0.38		9.12	3000	131.80	3.73	7.32	0.29	48.1
RS1232x24H	0.45		10.8	3500	153.06	4.33	9.88	0.39	51.0
RS1232x24VH	0.50		12	4000	174.32	4.93	11.81	0.46	54.5
RS1232x48D	48(35~57)		0.03	1.44	2000	89.28	2.53	3.36	0.13
RS1232x48L		0.08	3.84	2500	110.54	3.13	5.15	0.20	42.6
RS1232x48M		0.19	9.12	3000	131.80	3.73	7.32	0.29	48.1
RS1232x48H		0.22	10.56	3500	153.06	4.33	9.88	0.39	51.0
RS1232x48VH		0.25	12	4000	174.32	4.93	11.81	0.46	54.5

★ 如果您需要的转速或电压或功能不在这份清单上, 请与我们联系。  
If you want another rpm or voltage or functions which one is not in the list, please contact with our sales.

★ 提示1:功能的具体信息参照产品目录前页篇章。  
Notes1:The catalog have detail information in the front page for the functions.

★ 提示2:产品详细信息请参照承认书。  
Notes2:Product have a detail in the approval sheet.

★ 提示3:产品规格变更不另行通知。  
Notes3:Specifications are subject to change without notice.

## DC AXIAL FAN

### 120x120x38mm

### RS1238 Series



外框材质:环保防火PBT  
Frame:Thermoplastic PBT UL94-V0  
扇叶材质:环保防火PBT  
Impeller:Thermoplastic PBT UL94-V0  
轴承结构:双滚珠或长寿命含油结构  
Bearing system:2Ball or Long life sleeve  
单体风扇重量:280g  
Unit Weight:280g

DIMENSIONS DRAWING

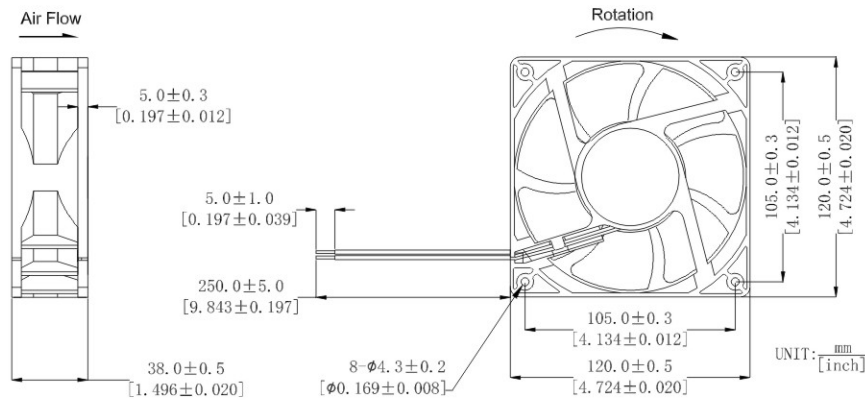

Fan Performance Curve

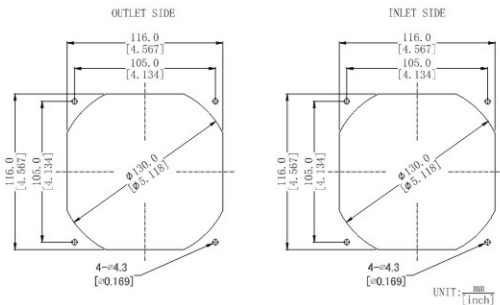
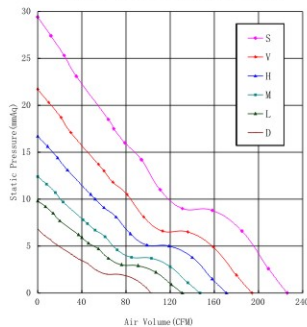

#### 可选的功能参照列表 (Available Functions)

##### 1.马达保护(Motor protection)

RP	SS	AS	CL
●	●	●	●

##### 2.信号输出(Signal output)

FG	RD	RD	LD
●	●	●	●

##### 3.调速方式(Speed control mode)

PWM	TP	VC	RC	CS
●	●	●	●	●

Part Number	Voltage(V)	Current(A)	Power(W)	Speed(RPM)	Air flow(Q)	Pressure(P)	Noise(dBA)	
产品编号	电压范围	额定电流	功率	转速	(CFM) 风量	(mmAq)风压	噪音	
RS1238x12D	12(7~14)	0.50	6.00	2600	103.03	2.92	6.11	41.7
RS1238x12L		0.66	7.92	3200	126.93	3.59	9.25	47.8
RS1238x12M		0.98	11.76	3600	142.80	4.04	11.71	50.2
RS1238x12H		1.22	14.64	4200	166.60	4.71	15.93	55.1
RS1238x12VH		1.60	19.20	4800	190.40	5.39	20.82	59.2
RS1238x12SH	24(15~27)	2.60	31.20	5600	222.13	6.29	28.34	64.8
RS1238x24D		0.25	6.00	2600	103.03	2.92	6.11	41.7
RS1238x24L		0.33	7.92	3200	126.93	3.59	9.25	47.8
RS1238x24M		0.49	11.76	3600	142.80	4.04	11.71	50.2
RS1238x24H		0.61	14.64	4200	166.60	4.71	15.93	55.1
RS1238x24VH	0.80	19.20	4800	190.40	5.39	20.82	59.2	
RS1238x24SH	1.30	31.20	5600	222.13	6.29	28.34	64.8	
RS1238x48D	48(35~57)	0.12	5.76	2600	103.03	2.92	6.11	41.7
RS1238x48L		0.16	7.68	3200	126.93	3.59	9.25	47.8
RS1238x48M		0.25	12.00	3600	142.80	4.04	11.71	50.2
RS1238x48H		0.30	14.40	4200	166.60	4.71	15.93	55.1
RS1238x48VH		0.40	19.20	4800	190.40	5.39	20.82	59.2
RS1238x48SH	0.65	31.20	5600	222.13	6.29	28.34	64.8	

★如果您需要的转速或电压或功能不在这份清单上, 请与我们联系。  
If you want another rpm or voltage or functions which one is not in the list, please contact with our sales.

★提示1:功能的具体信息参照产品目录前页篇章。  
Notes1: The catalog have detail information in the front page for the functions.

★提示2:产品详细信息请参照承认书。  
Notes2: Product have a detail in the approval sheet.

★提示3:产品规格变更不另行通知。  
Notes3: Specifications are subject to change without notice.

## DC AXIAL FAN

### 120x120x38mm

### RD1238 Series



外框材质:环保防火PBT  
Frame:Thermoplastic PBT UL94-V0  
扇叶材质:环保防火PBT  
Impeller:Thermoplastic PBT UL94-V0  
轴承结构:双滚珠  
Bearing system:2Ball  
单体风扇重量:380g  
Unit Weight:380g

DIMENSIONS DRAWING

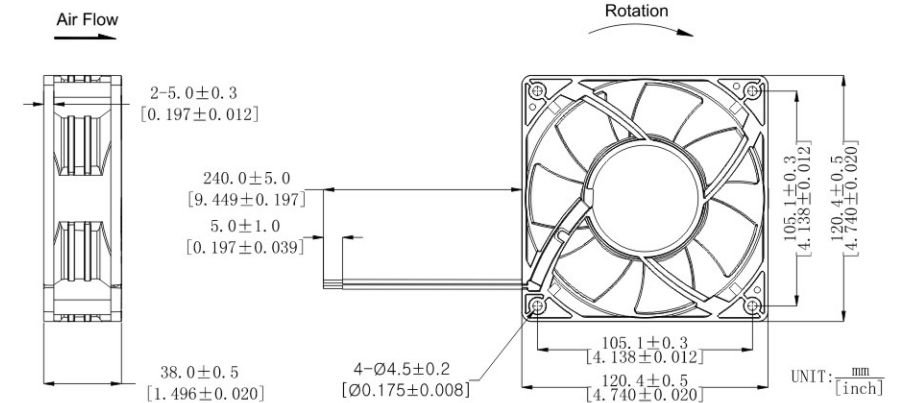

Fan Performance Curve

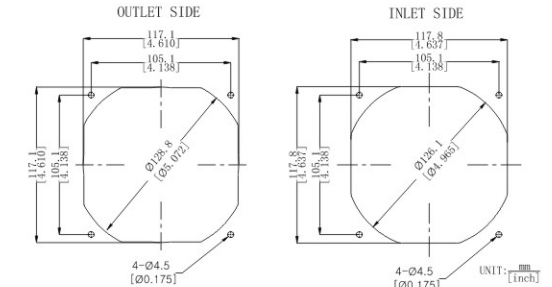
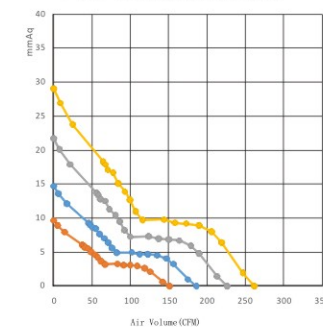

#### 可选的功能参照列表 (Available Functions)

##### 1.马达保护(Motor protection)

RP	SS	AS	CL
●	●	●	●

##### 2.信号输出(Signal output)

FG	RD	RD	LD
●	●	●	●

##### 3.调速方式(Speed control mode)

PWM	TP	VC	RC	CS
●	●	●	●	●

Part Number	Voltage(V)	Current(A)	Power(W)	Speed(RPM)	Air flow(Q)	Pressure(P)	Noise(dBA)	
产品编号	电压范围	额定电流	功率	转速	(CFM) 风量	(mmAq)风压	噪音	
RD1238X12L	12(7~14)	0.43	5.16	3000	150.92	4.27	9.66	39.5
RD1238X12M		1	12	3700	186.13	5.27	14.69	46.3
RD1238X12H		1.5	18	4500	226.37	6.4	21.74	49.6
RD1238X12VH		2.5	30	5200	261.59	7.4	29.02	56.7
RD1238X24L		24(15~27)	0.22	5.28	3000	150.92	4.27	9.66
RD1238X24M	0.5		12	3700	186.13	5.27	14.69	46.3
RD1238X24H	0.75		18	4500	226.37	6.4	21.74	49.6
RD1238X24VH	1.4	33.6	5200	261.59	7.4	29.02	56.7	
RD1238X48L	48(35~57)	0.11	5.28	3000	150.92	4.27	9.66	39.5
RD1238X48M		0.25	12	3700	186.13	5.27	14.69	46.3
RD1238X48H		0.38	18	4500	226.37	6.4	21.74	49.6
RD1238X48VH		0.7	33.6	5200	261.59	7.4	29.02	56.7

★如果您需要的转速或电压或功能不在这份清单上, 请与我们联系。  
If you want another rpm or voltage or functions which one is not in the list, please contact with our sales.

★提示1:功能的具体信息参照产品目录前页篇章。  
Notes1: The catalog have detail information in the front page for the functions.

★提示2:产品详细信息请参照承认书。  
Notes2: Product have a detail in the approval sheet.

★提示3:产品规格变更不另行通知。  
Notes3: Specifications are subject to change without notice.

## DC AXIAL FAN

### 120x120x38mm

#### RD1238 Series



外框材质:环保防火PBT  
Frame:Thermoplastic PBT UL94-V0  
扇叶材质:环保防火PBT  
Impeller:Thermoplastic PBT UL94-V0  
轴承结构:双滚珠  
Bearing system:2Ball  
单体风扇重量:380g  
Unit Weight:380g

DIMENSIONS DRAWING

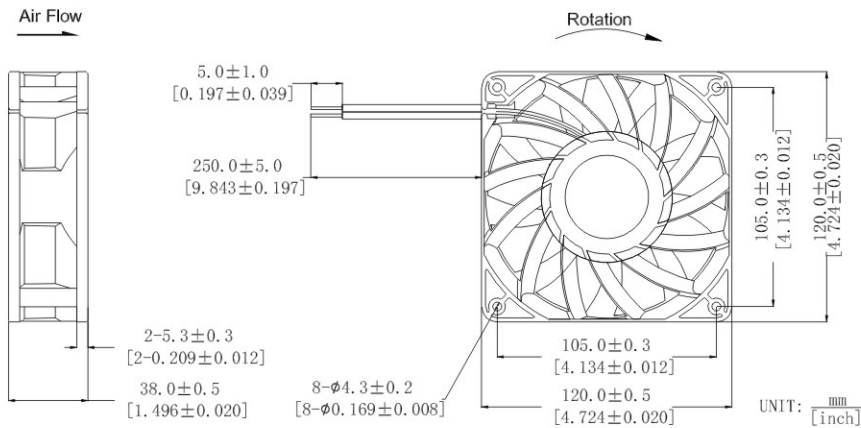

#### 可选的功能参照列表 (Available Functions)

1.马达保护(Motor protection)

RP	SS	AS	CL
●	●	●	●

2.信号输出(Signal output)

FG	RD	RD	LD
●	●	●	●

3.调速方式(Speed control mode)

PWM	TP	VC	RC	CS
●	●	●	●	●

Fan Performance Curve

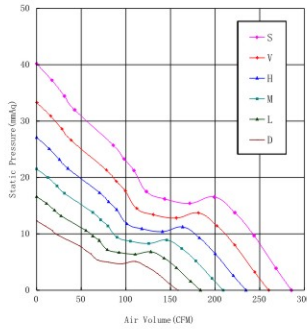

OUTLET SIDE

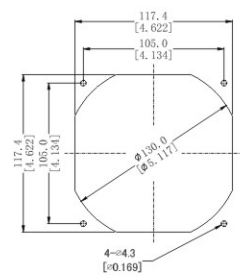

INLET SIDE

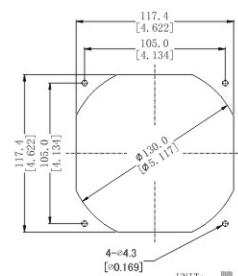

Part Number	Voltage(V)	Current(A)	Power(W)	Speed(RPM)	Air flow(Q)	Pressure(P)	Noise(dBA)		
产品编号	电压范围	额定电流	功率	转速	(CFM) 风量	m <sup>3</sup> /min (mmAq)风压 (In H <sub>2</sub> O)	噪音		
RD1238B12D	12(7~14)	0.86	10.32	3000	158.12	4.47	12.36	0.49	54.3
RD1238B12L		1.30	15.60	3500	183.60	5.20	16.66	0.66	58.5
RD1238B12M		1.86	22.32	4000	209.11	5.92	21.53	0.85	61.7
RD1238B12H		2.60	31.20	4500	234.65	6.64	27.20	1.07	64.6
RD1238B12VH		1.90	45.60	5000	260.30	7.37	33.42	1.32	67.9
RD1238B24D	24(15~27)	0.43	10.32	3000	158.12	4.47	12.36	0.49	54.3
RD1238B24L		0.65	15.60	3500	183.60	5.20	16.66	0.66	58.5
RD1238B24M		0.93	22.32	4000	209.11	5.92	21.53	0.85	61.7
RD1238B24H		1.30	31.20	4500	234.65	6.64	27.20	1.07	64.6
RD1238B24VH	1.90	45.60	5000	260.30	7.37	33.42	1.32	67.9	
RD1238B48D	48(35~57)	0.21	10.08	3000	158.12	4.47	12.36	0.49	54.3
RD1238B48L		0.32	15.36	3500	183.60	5.20	16.66	0.66	58.5
RD1238B48M		0.46	22.08	4000	209.11	5.92	21.53	0.85	61.7
RD1238B48H		0.65	31.20	4500	234.65	6.64	27.20	1.07	64.6
RD1238B48VH		0.95	45.60	5000	260.30	7.37	33.42	1.32	67.9
RD1238B48SH		1.16	55.68	5500	285.69	8.09	40.24	1.58	71.2

★ 如果您需要的转速或电压或功能不在这份清单上, 请与我们联系。  
If you want another rpm or voltage or functions which one is not in the list, please contact with our sales.

★ 提示1:功能的具体信息参照产品目录前页篇章。  
Notes1:The catalog have detail information in the front page for the functions.

★ 提示2:产品详细信息请参照承认书。  
Notes2:Product have a detail in the approval sheet.

★ 提示3:产品规格变更不另行通知。  
Notes3:Specifications are subject to change without notice.

## DC AXIAL FAN

### 120x120x38mm

#### RD1238 C Series



外框材质:环保防火PBT  
Frame:Thermoplastic PBT UL94-V0  
扇叶材质:环保防火PBT  
Impeller:Thermoplastic PBT UL94-V0  
轴承结构:双滚珠  
Bearing system:2Ball  
单体风扇重量:380g  
Unit Weight:380g

DIMENSIONS DRAWING

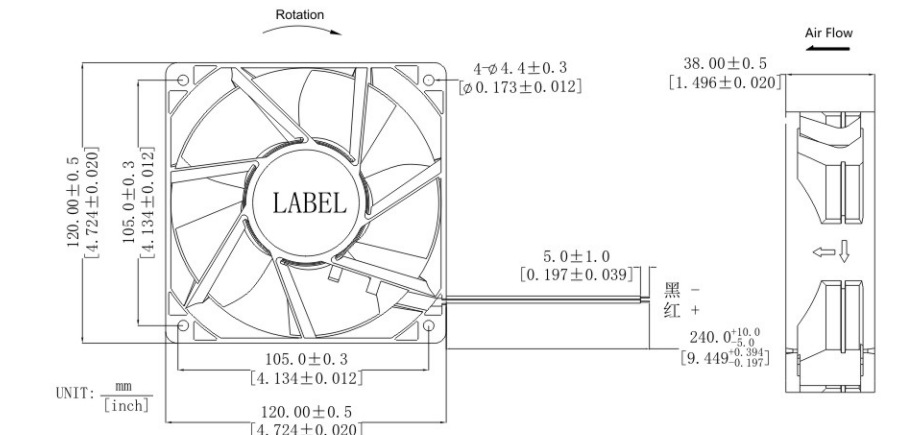

#### 可选的功能参照列表 (Available Functions)

1.马达保护(Motor protection)

RP	SS	AS	CL
●	●	●	●

2.信号输出(Signal output)

FG	RD	RD	LD
●	●	●	●

3.调速方式(Speed control mode)

PWM	TP	VC	RC	CS
●	●	●	●	●

风量风压PQ曲线图 Fan Performance Curve

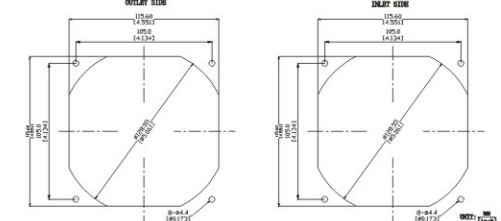
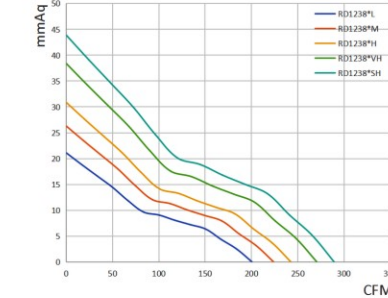

Part Number	Voltage(V)	Current(A)	Power(W)	Speed(RPM)	Air flow(Q)	Pressure(P)	Noise(dBA)		
产品编号	电压范围	额定电流	功率	转速	(CFM) 风量	m <sup>3</sup> /min (mmAq)风压 (In H <sub>2</sub> O)	噪音		
RD1238B12L2	12(7~14)	1.00	12.00	4300	200.68	5.68	21.11	0.83	56.40
RD1238B12M2		1.36	16.32	4800	224.02	6.34	26.30	1.04	58.66
RD1238B12H2		1.72	20.64	5200	242.69	6.87	30.87	1.22	61.76
RD1238B12VH2		2.45	29.40	5800	270.69	7.66	38.40	1.51	64.23
RD1238B12SH2		2.70	32.40	6200	289.36	8.19	43.88	1.73	66.80
RD1238B24L2	24(15~27)	0.50	12.00	4300	200.68	5.68	21.11	0.83	56.40
RD1238B24M2		0.68	16.32	4800	224.02	6.34	26.30	1.04	58.66
RD1238B24H2		0.86	20.64	5200	242.69	6.87	30.87	1.22	61.76
RD1238B24VH2		1.23	29.52	5800	270.69	7.66	38.40	1.51	64.23
RD1238B24SH2	1.35	32.40	6200	289.36	8.19	43.88	1.73	66.80	
RD1238B48L2	48(35~57)	0.25	12.00	4300	200.68	5.68	21.11	0.83	56.40
RD1238B48M2		0.34	16.32	4800	224.02	6.34	26.30	1.04	58.66
RD1238B48H2		0.43	20.64	5200	242.69	6.87	30.87	1.22	61.76
RD1238B48VH2		0.62	29.76	5800	270.69	7.66	38.40	1.51	64.23
RD1238B48SH2		0.68	32.64	6200	289.36	8.19	43.88	1.73	66.80

★ 如果您需要的转速或电压或功能不在这份清单上, 请与我们联系。  
If you want another rpm or voltage or functions which one is not in the list, please contact with our sales.

★ 提示1:功能的具体信息参照产品目录前页篇章。  
Notes1:The catalog have detail information in the front page for the functions.

★ 提示2:产品详细信息请参照承认书。  
Notes2:Product have a detail in the approval sheet.

★ 提示3:产品规格变更不另行通知。  
Notes3:Specifications are subject to change without notice.

## DC AXIAL FAN

### 130x130x38mm

#### RD1338 Series



DIMENSIONS DRAWING

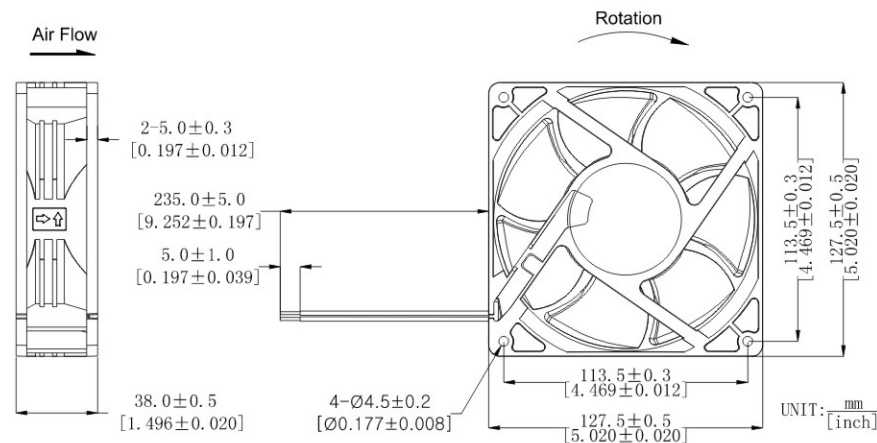

外框材质:环保防火PBT  
 Frame:Thermoplastic PBT UL94-V0  
 扇叶材质:环保防火PBT  
 Impeller:Thermoplastic PBT UL94-V0  
 轴承结构:双滚珠  
 Bearing system:2Ball  
 单体风扇重量:380g  
 Unit Weight:380g

#### 可选的功能参照列表 (Available Functions)

1.马达保护(Motor protection)

RP	SS	AS	CL
●	●	●	●

2.信号输出(Signal output)

FG	RD	RD	LD
●	●	●	●

3.调速方式(Speed control mode)

PWM	TP	VC	RC	CS
●	●	●	●	●

Fan Performance Curve

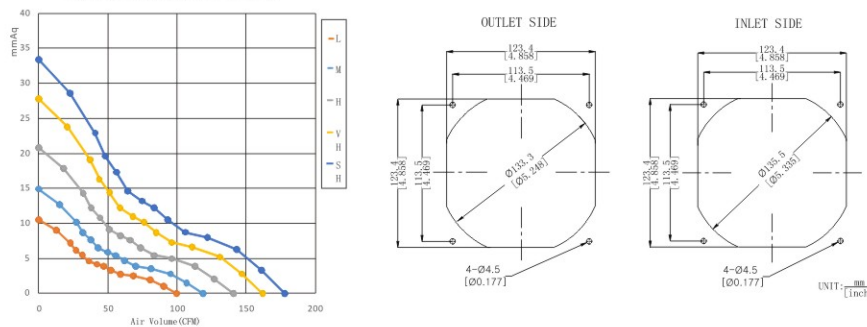

Part Number	Voltage(V)	Current(A)	Power(W)	Speed(RPM)	Air flow(Q)	Pressure(P)	Noise(dBA)
产品编号	电压范围	额定电流	功率	转速	(CFM) 风量	(mmAq)风压 (In H <sub>2</sub> O)	噪音
RD1338B12L	12(7~14)	0.46	5.52	3100	96.83	2.74	46.96
RD1338B12M		0.78	9.36	3800	118.69	3.36	50.15
RD1388B12H		1.24	14.88	4500	140.55	3.98	53.24
RD1388B12VH		1.68	20.16	5200	162.42	4.59	56.27
RD1338B24L	24(15~27)	0.23	5.52	3100	96.83	2.74	46.96
RD1338B24M		0.39	9.36	3800	118.69	3.36	50.15
RD1338B24H		0.62	14.88	4500	140.55	3.98	53.24
RD1338B24VH		0.84	20.16	5200	162.42	4.59	56.27
RD1338B24SH	1.05	25.2	5700	178.03	5.04	58.91	
RD1338B48L	48(35~57)	0.11	5.28	3100	96.83	2.74	46.96
RD1338B48M		0.19	9.12	3800	118.69	3.36	50.15
RD1338B48H		0.32	15.36	4500	140.55	3.98	53.24
RD1338B48VH		0.42	20.16	5200	162.42	4.59	56.27
RD1338B48SH		0.52	24.96	5700	178.03	5.04	58.92

★ 如果您需要的转速或电压或功能不在这份清单上, 请与我们联系。  
 If you want another rpm or voltage or functions which one is not in the list, please contact with our sales.

★ 提示1:功能的具体信息参照产品目录前页篇章。  
 Notes1:The catalog have detail information in the front page for the functions.

★ 提示2:产品详细信息请参照承认书。  
 Notes2:Product have a detail in the approval sheet.

★ 提示3:产品规格变更不另行通知。  
 Notes3:Specifications are subject to change without notice.

## DC AXIAL FAN

### 140x140x25mm

#### RS1425 Series



DIMENSIONS DRAWING

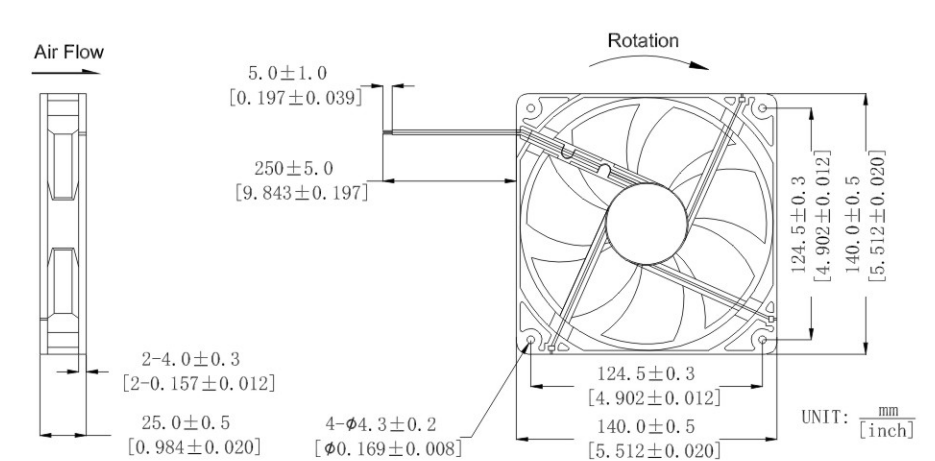

外框材质:环保防火PBT  
 Frame:Thermoplastic PBT UL94-V0  
 扇叶材质:环保防火PBT  
 Impeller:Thermoplastic PBT UL94-V0  
 轴承结构:双滚珠或长寿命含油结构  
 Bearing system:2Ball or Long life sleeve  
 单体风扇重量:200g  
 Unit Weight:200g

#### 可选的功能参照列表 (Available Functions)

1.马达保护(Motor protection)

RP	SS	AS	CL
●	●	●	●

2.信号输出(Signal output)

FG	RD	RD	LD
●	●	●	●

3.调速方式(Speed control mode)

PWM	TP	VC	RC	CS
●	●	●	●	●

Fan Performance Curve

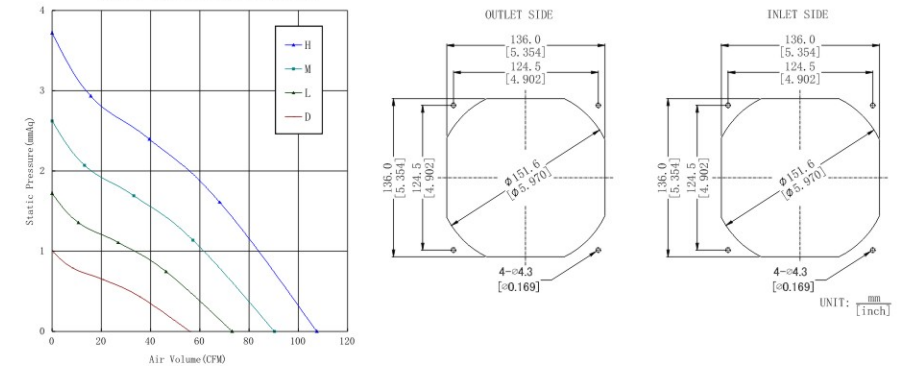

Part Number	Voltage(V)	Current(A)	Power(W)	Speed(RPM)	Air flow(Q)	Pressure(P)	Noise(dBA)
产品编号	电压范围	额定电流	功率	转速	(CFM) 风量	(mmAq)风压 (In H <sub>2</sub> O)	噪音
RS1425x12D	12(7~14)	0.01	0.12	1200	55.90	1.58	26.8
RS1425x12L		0.13	1.56	1600	73.10	2.07	33.4
RS1425x12M		0.20	2.40	2000	90.30	2.56	39.4
RS1425x12H		0.36	4.32	2400	107.50	3.04	43.8
RS1425x24D	24(15~27)	0.05	1.20	1200	55.90	1.58	26.8
RS1425x24L		0.07	1.68	1600	73.10	2.07	33.4
RS1425x24M		0.10	2.40	2000	90.30	2.56	39.4
RS1425x24H		0.18	4.32	2400	107.50	3.04	43.8

★ 如果您需要的转速或电压或功能不在这份清单上, 请与我们联系。  
 If you want another rpm or voltage or functions which one is not in the list, please contact with our sales.

★ 提示1:功能的具体信息参照产品目录前页篇章。  
 Notes1:The catalog have detail information in the front page for the functions.

★ 提示2:产品详细信息请参照承认书。  
 Notes2:Product have a detail in the approval sheet.

★ 提示3:产品规格变更不另行通知。  
 Notes3:Specifications are subject to change without notice.

## DC AXIAL FAN

### 140x140x38mm

#### RD1438 Series



DIMENSIONS DRAWING

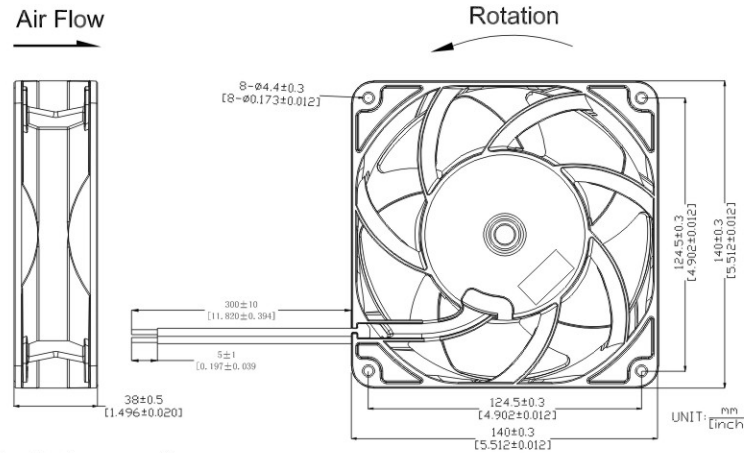

外框材质:环保防火PBT  
 Frame:Thermoplastic PBT UL94-V0  
 扇叶材质:环保防火PBT  
 Impeller:Thermoplastic PBT UL94-V0  
 轴承结构:双滚珠或长寿命含油结构  
 Bearing system:2Ball or Long life sleeve  
 单体风扇重量:380g  
 Unit Weight:380g

#### 可选的功能参照列表 (Available Functions)

1.马达保护(Motor protection)

RP	SS	AS	CL
●	●	●	●

2.信号输出(Signal output)

FG	RD	RD	LD
●	●	●	●

3.调速方式(Speed control mode)

PWM	TP	VC	RC	CS
●	●	●	●	●

Fan Performance Curve

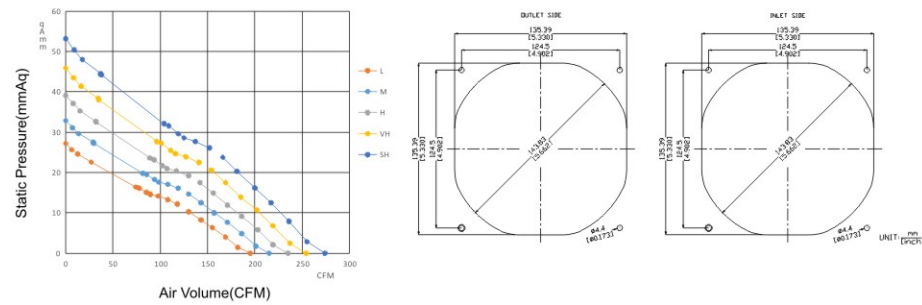

Part Number	Voltage(V)	Current(A)	Power(W)	Speed(RPM)	Air flow(Q)	Pressure(P)	Noise(dBA)		
产品编号	电压范围	额定电流	功率	转速	(CFM)风量	m <sup>3</sup> /min	(mmAq)风压	(In H <sub>2</sub> O)	噪音
RD1438B12L	12(7~14)	1.58	18.96	5000	195.42	5.53	27.15	1.07	55.56
RD1438B12M		1.90	22.8	5500	214.96	6.08	32.85	1.29	57.58
RD1438B12H		2.45	29.04	6000	234.5	6.63	39.1	1.54	59.41
RD1438B12VH		3.10	37.2	6500	254.04	7.19	45.89	1.81	60.73
RD1438B24L	24(15~27)	0.79	18.96	5000	195.42	5.53	27.15	1.07	55.56
RD1438B24M		0.95	22.8	5500	214.96	6.08	32.85	1.29	57.58
RD1438B24H		1.21	29.04	6000	234.5	6.63	39.1	1.54	59.41
RD1438B24VH		1.55	37.2	6500	254.04	7.19	45.89	1.81	60.73
RD1438B24SH		2.10	50.4	7000	273.59	7.74	53.22	2.1	64.2
RD1438B48L	48(35~57)	0.40	18.96	5000	195.42	5.53	27.15	1.07	55.56
RD1438B48M		0.48	22.8	5500	214.96	6.08	32.85	1.29	57.58
RD1438B48H		0.60	29.04	6000	234.5	6.63	39.1	1.54	59.41
RD1438B48VH		0.78	37.2	6500	254.04	7.19	45.89	1.81	60.73
RD1438B48SH		1.05	50.4	7000	273.59	7.74	53.22	2.1	64.2

★ 如果您需要的转速或电压或功能不在这份清单上, 请与我们联系。  
 If you want another rpm or voltage or functions which one is not in the list, please contact with our sales.

★ 提示1:功能的具体信息参照产品目录前页篇章。  
 Notes1:The catalog have detail information in the front page for the functions.

★ 提示2:产品详细信息请参照承认书。  
 Notes2:Product have a detail in the approval sheet.

★ 提示3:产品规格变更不另行通知。  
 Notes3:Specifications are subject to change without notice.

★ 提示4:调速方式只能制作12V机型。  
 Note4:Speed control mode only for 12V products.

## DC AXIAL FAN

### 140x140x50mm

#### RD14050 Series



DIMENSIONS DRAWING

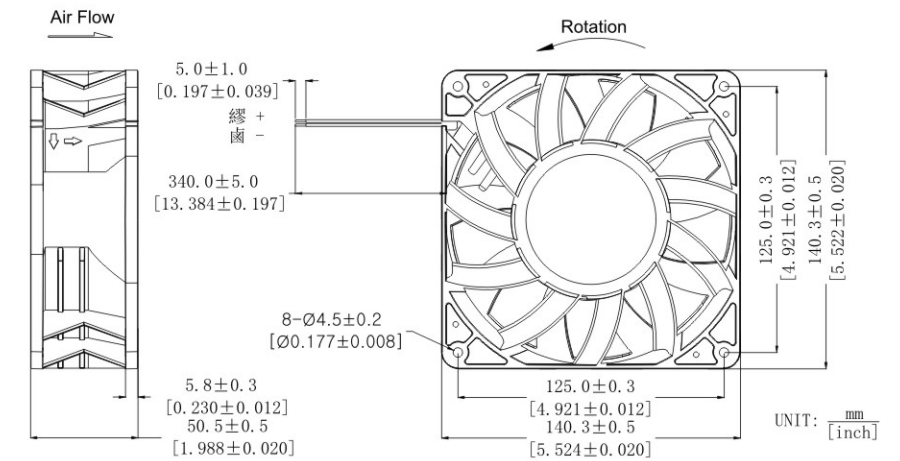

外框材质:环保防火PBT+GF  
 Frame:Thermoplastic PBT+GF UL94-V0  
 扇叶材质:环保防火PBT+GF  
 Impeller:Thermoplastic PBT+GF UL94-V0  
 轴承结构:双滚珠或长寿命含油结构  
 Bearing system:2Ball or Long life sleeve  
 单体风扇重量:400g  
 Unit Weight:400g

#### 可选的功能参照列表 (Available Functions)

1.马达保护(Motor protection)

RP	SS	AS	CL
●	●	●	●

2.信号输出(Signal output)

FG	RD	RD	LD
●	●	●	●

3.调速方式(Speed control mode)

PWM	TP	VC	RC	CS
●	●	●	●	●

Fan Performance Curve

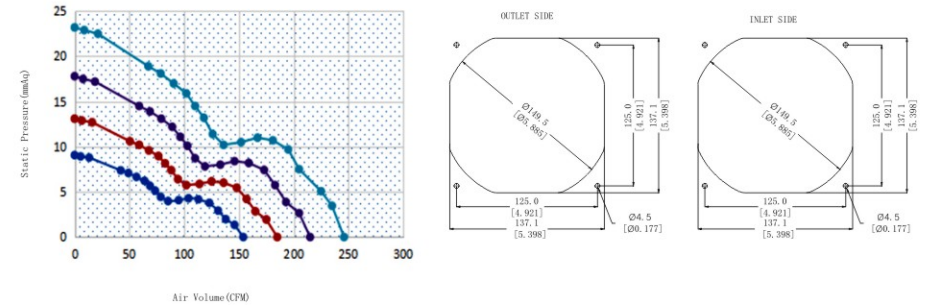

Part Number	Voltage(V)	Current(A)	Power(W)	Speed(RPM)	Air flow(Q)	Pressure(P)	Noise(dBA)		
产品编号	电压范围	额定电流	功率	转速	(CFM)风量	m <sup>3</sup> /min	(mmAq)风压	(In H <sub>2</sub> O)	噪音
RD14050X12D	12(7~14)	0.82	9.84	2500	166.41	4.71	9.5	0.37	49.71
RD14050X12L		1.35	16.20	3000	199.69	5.65	13.68	0.54	55.52
RD14050X12H		2.05	24.60	3500	232.97	6.59	18.62	0.73	59.21
RD14050X12VH		3.10	37.20	4000	266.25	7.53	24.32	0.96	62.76
RD14050X24D	24(15~27)	0.40	9.60	2500	166.41	4.71	9.5	0.37	49.71
RD14050X24L		0.65	15.60	3000	199.69	5.65	13.68	0.54	55.52
RD14050X24H		1.0	24.00	3500	232.97	6.59	18.62	0.73	59.21
RD14050X24VH		1.5	36.00	4000	266.25	7.53	24.32	0.96	62.76
RD14050X48D	48(35~57)	0.22	10.56	2500	166.41	4.71	9.5	0.37	49.71
RD14050X48L		0.32	15.36	3000	199.69	5.65	13.68	0.54	55.52
RD14050X48H		0.50	24.00	3500	232.97	6.59	18.62	0.73	59.21
RD14050X48VH		0.75	36.00	4000	266.25	7.53	24.32	0.96	62.76

★ 如果您需要的转速或电压或功能不在这份清单上, 请与我们联系。  
 If you want another rpm or voltage or functions which one is not in the list, please contact with our sales.

★ 提示1:功能的具体信息参照产品目录前页篇章。  
 Notes1:The catalog have detail information in the front page for the functions.

★ 提示2:产品详细信息请参照承认书。  
 Notes2:Product have a detail in the approval sheet.

★ 提示3:产品规格变更不另行通知。  
 Notes3:Specifications are subject to change without notice.

# DC AXIAL FAN

## 150x150x51mm

### RS1551 Series



DIMENSIONS DRAWING

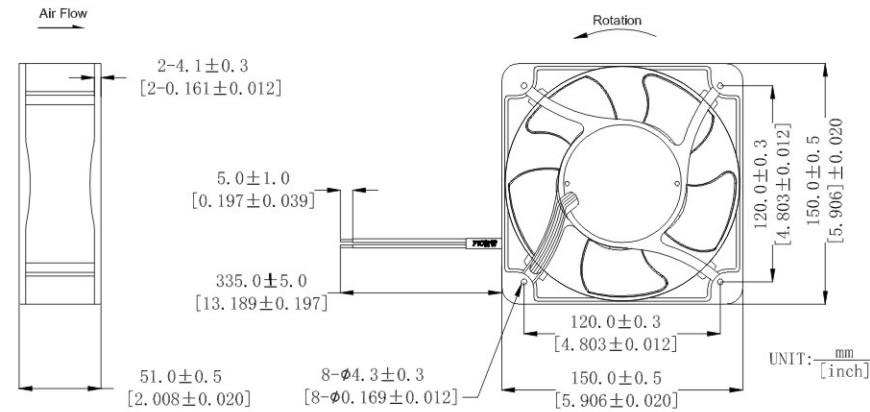

Fan Performance Curve

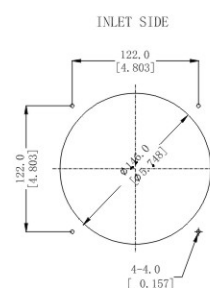
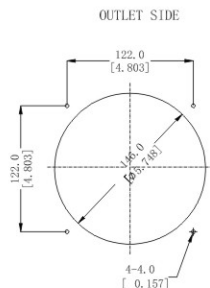
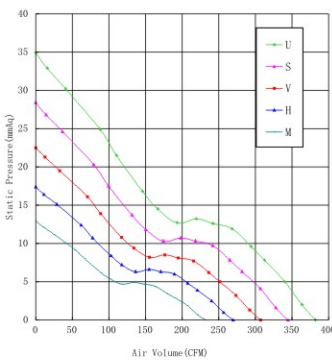

UNIT: mm [inch]



外框材质:铝合金  
Frame:Aluminum  
扇叶材质:环保防火PBT  
Impeller:Thermoplastic PBT UL94-V0  
轴承结构:双滚珠  
Bearing system:2Ball  
单体风扇重量:760g  
Unit Weight:760g

#### 可选的功能参照列表 (Available Functions)

1. 马达保护(Motor protection)

RP	SS	AS	CL
<input type="checkbox"/>	<input type="checkbox"/>	<input type="checkbox"/>	<input type="checkbox"/>

2. 信号输出(Signal output)

FG	RD	RD	LD
<input type="checkbox"/>	<input type="checkbox"/>	<input type="checkbox"/>	<input type="checkbox"/>

3. 调速方式(Speed control mode)

PWM	TP	VC	RC	CS
<input type="checkbox"/>	<input type="checkbox"/>	<input type="checkbox"/>	<input type="checkbox"/>	<input type="checkbox"/>

Part Number	Voltage(V)	Current(A)	Power(W)	Speed(RPM)	Air flow(Q)	Pressure(P)	Noise(dBA)
产品编号	电压范围	额定电流	功率	转速	(CFM) 风量	(mmAq)风压	(In H <sub>2</sub> O) 噪音
RS1551B12M	12(7~14)	1.16	13.92	3000	232.20	6.56	52.3
RS1551B12H		1.76	21.12	3500	269.65	7.62	56.6
RS1551B12VH		2.42	29.04	4000	307.11	8.68	60.5
RS1551B24M	24(15~28)	0.58	13.92	3000	232.20	6.56	52.3
RS1551B24H		0.88	21.12	3500	269.65	7.62	56.6
RS1551B24VH		1.21	29.04	4000	307.11	8.68	60.5
RS1551B24SH	48(35~58)	1.86	44.64	4500	344.56	9.74	62.3
RS1551B24UH		2.20	52.80	5000	382.01	10.80	66.8
RS1551B48M		0.29	13.92	3000	232.20	6.56	52.3
RS1551B48H	48(35~58)	0.44	21.12	3500	269.65	7.62	56.6
RS1551B48VH		0.60	28.80	4000	307.11	8.68	60.5
RS1551B48SH		0.93	44.64	4500	344.56	9.74	62.3
RS1551B48UH	48(35~58)	1.10	52.80	5000	382.01	10.80	66.8

★ 如果您需要的转速或电压或功能不在这份清单上, 请与我们联系。  
If you want another rpm or voltage or functions which one is not in the list, please contact with our sales.

★ 提示1:功能的具体信息参照产品目录前页篇章。  
Notes1:The catalog have detail information in the front page for the functions.

★ 提示2:产品详细信息请参照承认书。  
Notes2:Product have a detail in the approval sheet.

★ 提示3:产品规格变更不另行通知。  
Notes3:Specifications are subject to change without notice.

# DC AXIAL FAN

## 160x160x50mm

### RS16050 Series



DIMENSIONS DRAWING



外框材质:环保防火PBT  
Frame:Thermoplastic PBT UL94-V0  
扇叶材质:环保防火PBT  
Impeller:Thermoplastic PBT UL94-V0  
轴承结构:双滚珠或长寿命含油结构  
Bearing system:2Ball or Long life sleeve  
单体风扇重量:720g  
Unit Weight:720g

#### 可选的功能参照列表 (Available Functions)

1. 马达保护(Motor protection)

RP	SS	AS	CL
<input type="checkbox"/>	<input type="checkbox"/>	<input type="checkbox"/>	<input type="checkbox"/>

2. 信号输出(Signal output)

FG	RD	RD	LD
<input type="checkbox"/>	<input type="checkbox"/>	<input type="checkbox"/>	<input type="checkbox"/>

3. 调速方式(Speed control mode)

PWM	TP	VC	RC	CS
<input type="checkbox"/>	<input type="checkbox"/>	<input type="checkbox"/>	<input type="checkbox"/>	<input type="checkbox"/>

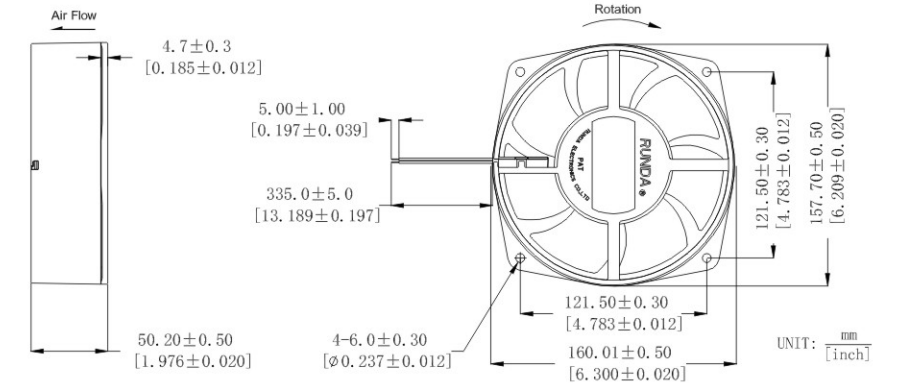

Fan Performance Curve

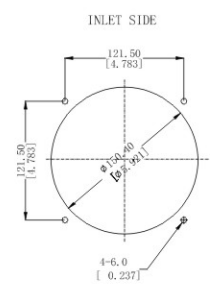
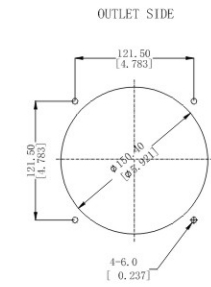
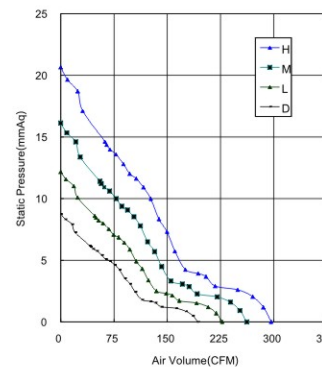

UNIT: mm [inch]

Part Number	Voltage(V)	Current(A)	Power(W)	Speed(RPM)	Air flow(Q)	Pressure(P)	Noise(dBA)
产品编号	电压范围	额定电流	功率	转速	(CFM) 风量	(mmAq)风压	(In H <sub>2</sub> O) 噪音
RS16050x12D	12(7~14)	1.00	12.00	2800	193.01	5.46	52.4
RS16050x12L		1.40	16.80	3300	227.47	6.44	57.1
RS16050x12M		2.20	26.40	3800	261.94	7.41	60.5
RS16050x24D	24(15~27)	0.50	12.00	2800	193.01	5.46	52.4
RS16050x24L		0.70	16.80	3300	227.47	6.44	57.1
RS16050x24M		1.10	26.40	3800	261.94	7.41	60.5
RS16050x24H	48(35~57)	1.40	33.60	4300	296.40	8.39	64.7
RS16050x48D		0.25	12.00	2800	193.01	5.46	52.4
RS16050x48L		0.35	16.80	3300	227.47	6.44	57.1
RS16050x48M	48(35~57)	0.55	26.40	3800	261.94	7.41	60.5
RS16050x48H		0.70	33.60	4300	296.40	8.39	64.7

★ 如果您需要的转速或电压或功能不在这份清单上, 请与我们联系。  
If you want another rpm or voltage or functions which one is not in the list, please contact with our sales.

★ 提示1:功能的具体信息参照产品目录前页篇章。  
Notes1:The catalog have detail information in the front page for the functions.

★ 提示2:产品详细信息请参照承认书。  
Notes2:Product have a detail in the approval sheet.

★ 提示3:产品规格变更不另行通知。  
Notes3:Specifications are subject to change without notice.

★ 提示4:调速方式只能制作12V机型。  
Note4:Speed control mode only for 12V products.

## DC AXIAL FAN

### 172x150x25mm

#### RS1725 Series



外框材质:环保防火PBT  
Frame:Thermoplastic PBT UL94-V0  
扇叶材质:环保防火PBT  
Impeller:Thermoplastic PBT UL94-V0  
轴承结构:双滚珠或长寿命含油结构  
Bearing system:2Ball or Long life sleeve  
单体风扇重量:460g  
Unit Weight:460g

DIMENSIONS DRAWING

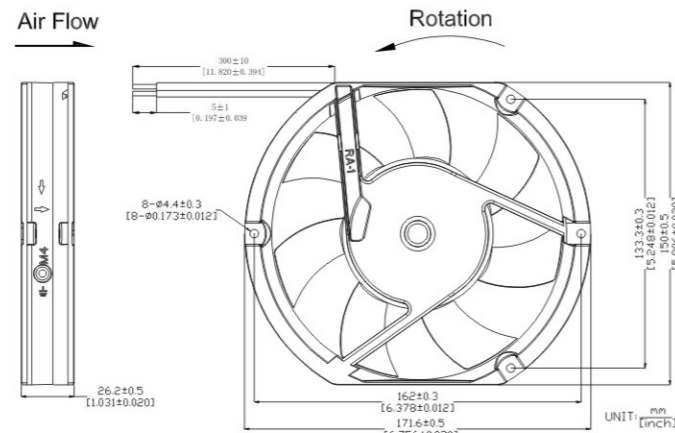

Fan Performance Curve

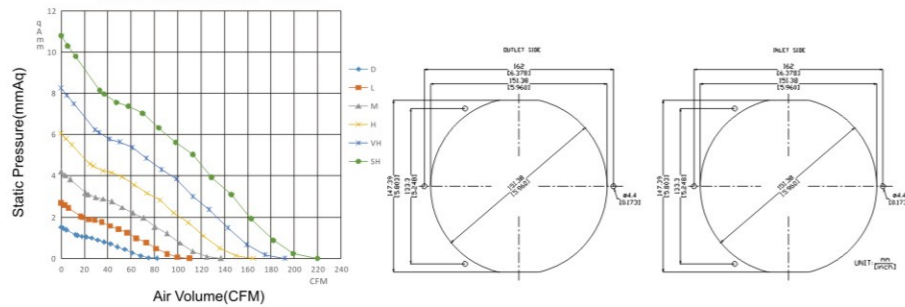

#### 可选的功能参照列表 (Available Functions)

##### 1.马达保护(Motor protection)

RP	SS	AS	CL
●	●	●	●

##### 2.信号输出(Signal output)

FG	RD	RD	LD
●	●	●	●

##### 3.调速方式(Speed control mode)

PWM	TP	VC	RC	CS
●	●	●	●	●

Part Number	Voltage(V)	Current(A)	Power(W)	Speed(RPM)	Air flow(Q)		Pressure(P)		Noise(dBA)
产品编号	电压范围	额定电流	功率	转速	(CFM) 风量	m <sup>3</sup> /min	(mmAq) 风压	(In H <sub>2</sub> O)	噪音
RS1725B12D	12(7~14)	0.23	2.8	1500	82.38	2.33	1.52	0.06	32
RS1725B12L		0.40	4.8	2000	109.84	3.11	2.7	0.11	38.7
RS1725B12M		0.63	7.5	2500	137.3	3.88	4.21	0.17	44.2
RS1725B12H		0.93	11.2	3000	164.76	4.66	6.07	0.24	49.5
RS1725B24D	24(15~27)	0.12	2.8	1500	82.38	2.33	1.52	0.06	32
RS1725B24L		0.20	4.8	2000	109.84	3.11	2.7	0.11	38.7
RS1725B24M		0.32	7.5	2500	137.3	3.88	4.21	0.17	44.2
RS1725B24H		0.47	11.2	3000	164.76	4.66	6.07	0.24	49.5
RS1725B24VH		0.73	17.5	3500	192.22	5.44	8.26	0.33	55.93
RS1725B24SH		1.07	25.7	4000	219.68	6.21	10.78	0.42	60.16
RS1725B48L	48(35~57)	0.10	4.8	2000	109.84	3.11	2.7	0.11	32
RS1725B48M		0.16	7.5	2500	137.3	3.88	4.21	0.17	38.7
RS1725B48H		0.23	11.2	3000	164.76	4.66	6.07	0.24	44.2
RS1725B48VH		0.36	17.5	3500	192.22	5.44	8.26	0.33	55.93
RS1725B48SH		0.53	25.7	4000	219.68	6.21	10.78	0.42	60.16

★ 如果您需要的转速或电压或功能不在这份清单上, 请与我们联系。  
If you want another rpm or voltage or functions which one is not in the list, please contact with our sales.

★ 提示1:功能的具体信息参照产品目录前页篇章。  
Notes1:The catalog have detail information in the front page for the functions.

★ 提示2:产品详细信息请参照承认书。  
Notes2:Product have a detail in the approval sheet.

★ 提示3:产品规格变更不另行通知。  
Notes3:Specifications are subject to change without notice.

★ 提示4:调速方式只能制作12V机型。  
Note4:Speed control mode only for 12V products.

## DC AXIAL FAN

### 172x150x51mm

#### RS1751 Series



全圆框也可生产 Round frame is available  
外框材质:铝合金  
Frame:Aluminum  
扇叶材质:环保防火PBT  
Impeller:Thermoplastic PBT UL94-V0  
轴承结构:双滚珠  
Bearing system:2Ball  
单体风扇重量:720g  
Unit Weight:720g

DIMENSIONS DRAWING

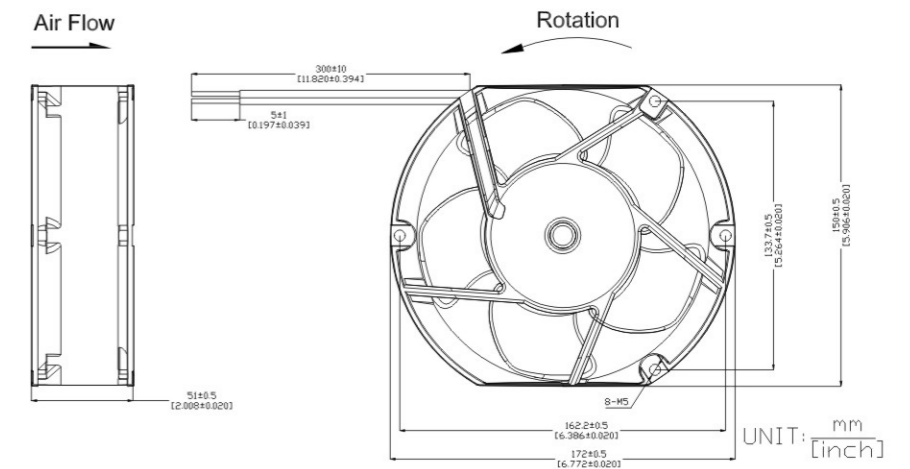

Fan Performance Curve

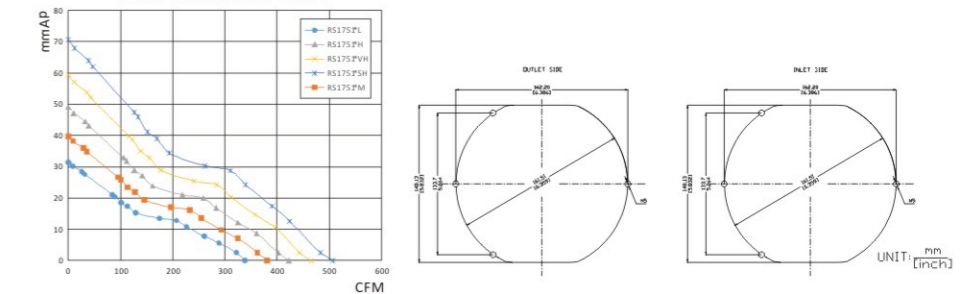

#### 可选的功能参照列表 (Available Functions)

##### 1.马达保护(Motor protection)

RP	SS	AS	CL
●	●	●	●

##### 2.信号输出(Signal output)

FG	RD	RD	LD
●	●	●	●

##### 3.调速方式(Speed control mode)

PWM	TP	VC	RC	CS
●	●	●	●	●

Part Number	Voltage(V)	Current(A)	Power(W)	Speed(RPM)	Air flow(Q)		Pressure(P)		Noise(dBA)
产品编号	电压范围	额定电流	功率	转速	(CFM) 风量	m <sup>3</sup> /min	(mmAq) 风压	(In H <sub>2</sub> O)	噪音
RS1751B12L	12(7~14)	2.00	24.00	4000	337.99	9.56	31.40	1.24	58.38
RS1751B12M		2.76	33.12	4500	380.24	10.76	39.74	1.56	60.79
RS1751B12H		4.00	48.00	5000	422.49	11.95	49.06	1.93	63.85
RS1751B24L		24(15~27)	1.00	24.00	4000	337.99	9.56	31.40	1.24
RS1751B24M	1.38		33.12	4500	380.24	10.76	39.74	1.56	60.79
RS1751B24H	2.00		48.00	5000	422.49	11.95	49.06	1.93	63.85
RS1751B24VH	2.98		71.40	5500	464.74	13.15	59.36	2.34	65.53
RS1751B24SH	3.60		86.40	6000	506.99	14.34	70.64	2.78	68.38
RS1751B48L	48(35~57)		0.50	24.00	4000	337.99	9.56	31.40	1.24
RS1751B48M		0.69	33.12	4500	380.24	10.76	39.74	1.56	60.79
RS1751B48H		1.00	48.00	5000	422.49	11.95	49.06	1.93	63.85
RS1751B48VH		1.49	71.40	5500	464.74	13.15	59.36	2.34	65.53
RS1751B48SH		1.80	86.40	6000	506.99	14.34	70.64	2.78	68.38

★ 如果您需要的转速或电压或功能不在这份清单上, 请与我们联系。  
If you want another rpm or voltage or functions which one is not in the list, please contact with our sales.

★ 提示1:功能的具体信息参照产品目录前页篇章。  
Notes1:The catalog have detail information in the front page for the functions.

★ 提示2:产品详细信息请参照承认书。  
Notes2:Product have a detail in the approval sheet.

★ 提示3:产品规格变更不另行通知。  
Notes3:Specifications are subject to change without notice.

## DC AXIAL FAN

### 172x150x51mm

#### RD1751 Series



全圆框也可生产 Round frame is available  
 外框材质:铝合金  
 Frame:Aluminum  
 扇叶材质:环保防火PBT  
 Impeller:Thermoplastic PBT UL94-V0  
 轴承结构:双滚珠  
 Bearing system:2Ball  
 单体风扇重量:760g  
 Unit Weight:760g

#### 可选的功能参照列表 (Available Functions)

1.马达保护(Motor protection)

RP	SS	AS	CL
●	●	●	●

2.信号输出(Signal output)

FG	RD	RD	LD
●	●	●	●

3.调速方式(Speed control mode)

PWM	TP	VC	RC	CS
●	●	●	●	●

DIMENSIONS DRAWING

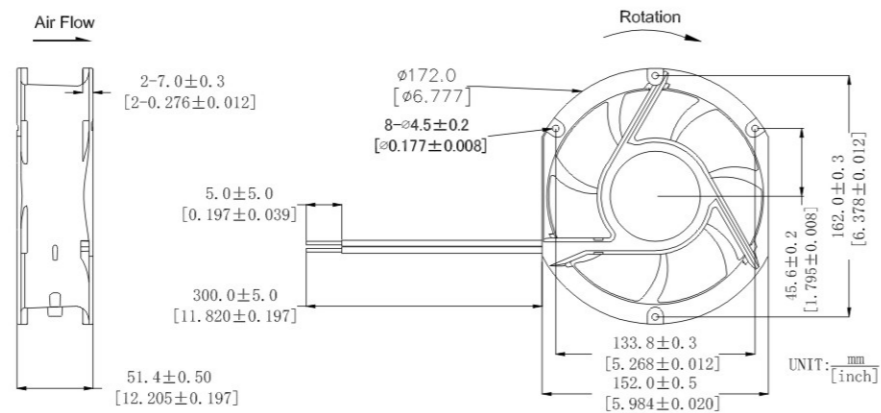

Fan Performance Curve

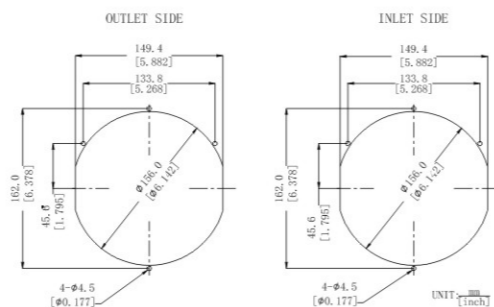
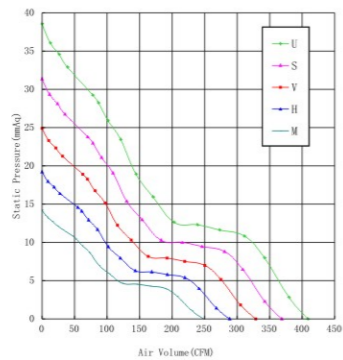

Part Number	Voltage(V)	Current(A)	Power(W)	Speed(RPM)	Air flow(Q)	Pressure(P)	Noise(dBA)
产品编号	电压范围	额定电流	功率	转速	(CFM) 风量	(mmAq)风压	(In H <sub>2</sub> O) 噪音
RD1751B12M	12(7~14)	1.58	18.96	3000	248.49	6.56	52.0
RD1751B12H		2.00	24.00	3500	288.57	7.62	57.5
RD1751B12VH		2.90	34.80	4000	328.65	8.68	60.8
RD1751B24M		0.79	18.96	3000	248.49	6.56	52.0
RD1751B24H	24(15~27)	1.00	24.00	3500	288.57	7.62	57.5
RD1751B24VH		1.45	34.80	4000	328.65	8.68	60.8
RD1751B24SH		2.00	48.00	4500	368.72	9.74	64.7
RD1751B24UH		2.60	62.40	5000	408.80	10.80	67.1
RD1751B48M	48(35~57)	0.40	19.20	3000	248.49	6.56	52.0
RD1751B48H		0.50	24.00	3500	288.57	7.62	57.5
RD1751B48VH		0.72	34.56	4000	328.65	8.68	60.8
RD1751B48SH		1.00	48.00	4500	368.72	9.74	64.7
RD1751B48UH		1.30	62.40	5000	408.80	10.80	67.1

★ 如果您需要的转速或电压或功能不在这份清单上, 请与我们联系。  
 If you want another rpm or voltage or functions which one is not in the list, please contact with our sales.

★ 提示1:功能的具体信息参照产品目录前页篇章。  
 Notes1:The catalog have detail information in the front page for the functions.

★ 提示2:产品详细信息请参照承诺书。  
 Notes2:Product have a detail in the approval sheet.

★ 提示3:产品规格变更不另行通知。  
 Notes3:Specifications are subject to change without notice.

## DC AXIAL FAN

### 200x200x60mm

#### RD 1751 C



外框材质:铝合金  
 Frame:Aluminum  
 扇叶材质:环保防火PC  
 Impeller:Thermoplastic PC UL94-V0  
 轴承结构:双滚珠  
 Bearing system:2Ball  
 单体风扇重量:1250g  
 Unit Weight:1250g

#### 可选的功能参照列表 (Available Functions)

1.马达保护(Motor protection)

RP	SS	AS	CL
●	●	●	●

2.信号输出(Signal output)

FG	RD	RD	LD
●	●	●	●

3.调速方式(Speed control mode)

PWM	TP	VC	RC	CS
●	●	●	●	●

DIMENSIONS DRAWING

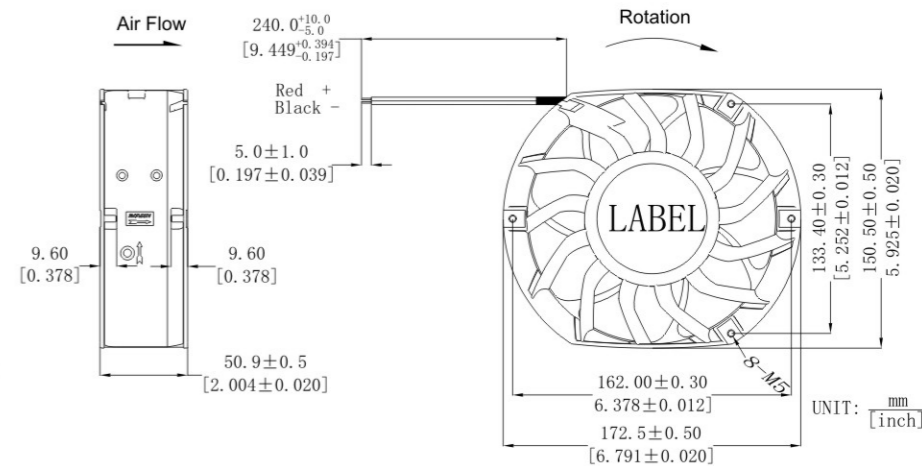

风量风压PQ曲线图 Fan Performance Curve

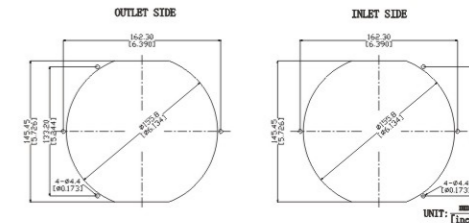
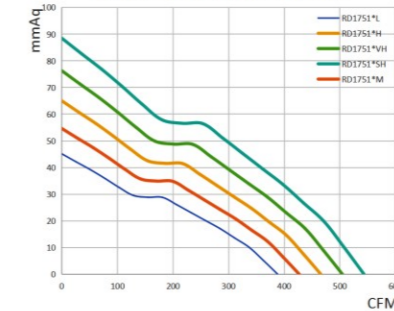

Part Number	Voltage(V)	Current(A)	Power(W)	Speed(RPM)	Air flow(Q)	Pressure(P)	Noise(dBA)
产品编号	电压范围	额定电流	功率	转速	(CFM) 风量	(mmAq)风压	(In H <sub>2</sub> O) 噪音
RD1751B12LL	12(7~14)	3.50	42.00	5000	388.12	11.01	54.60
RD1751B12ML		4.80	57.60	5500	426.93	12.11	59.70
RD1751B24LL	24(15~27)	1.75	42.00	5000	388.12	11.01	54.60
RD1751B24ML		2.40	57.60	5500	426.93	12.11	59.70
RD1751B24HL		2.95	70.80	6000	465.74	13.21	64.20
RD1751B24VHL		3.90	93.60	6500	504.65	14.32	67.50
RD1751B24SHL	48(35~57)	5.00	120.00	7000	543.37	15.41	71.50
RD1751B48LL		0.88	42.24	5000	388.12	11.01	54.60
RD1751B48ML		1.20	57.60	5500	426.93	12.11	59.70
RD1751B48HL		1.48	71.04	6000	465.74	13.21	64.20
RD1751B48VHL		1.95	93.60	6500	504.65	14.32	67.50
RD1751B48SHL	2.50	120.00	7000	543.37	15.41	71.50	

★ 如果您需要的转速或电压或功能不在这份清单上, 请与我们联系。  
 If you want another rpm or voltage or functions which one is not in the list, please contact with our sales.

★ 提示1:功能的具体信息参照产品目录前页篇章。  
 Notes1:The catalog have detail information in the front page for the functions.

★ 提示2:产品详细信息请参照承诺书。  
 Notes2:Product have a detail in the approval sheet.

★ 提示3:产品规格变更不另行通知。  
 Notes3:Specifications are subject to change without notice.

★ 提示4:调速方式只能制作12V机型。  
 Note4:Speed control mode only for 12V products.

## DC AXIAL FAN

### 180x180x60mm

#### RD 18060



外框材质:铝合金  
Frame:Aluminum  
扇叶材质:环保防火PC  
Impeller:Thermoplastic PC UL94-V0  
轴承结构:双滚珠  
Bearing system:2Ball  
单体风扇重量:1250g  
Unit Weight:1250g

DIMENSIONS DRAWING

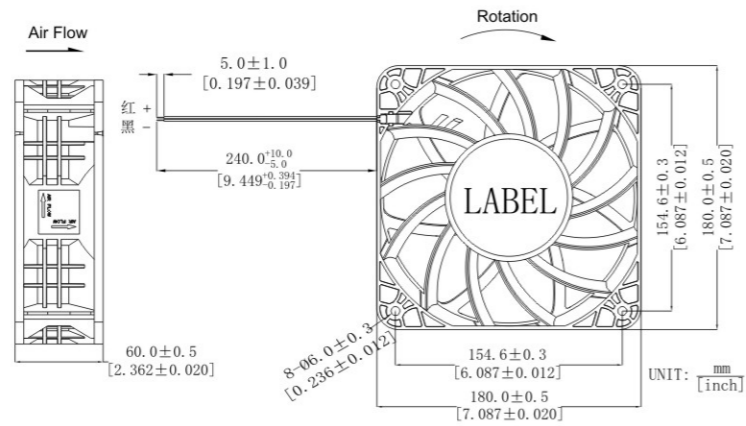

风量风压PQ曲线图 Fan Performance Curve

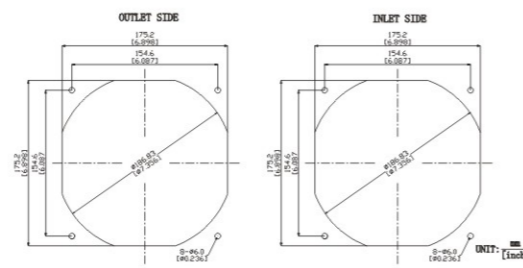
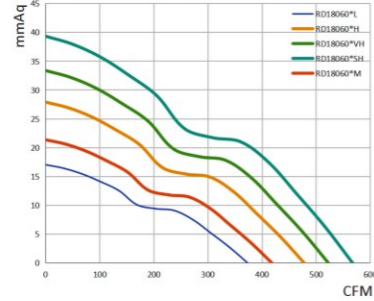

#### 可选的功能参照列表 (Available Functions)

1.马达保护(Motor protection)

RP	SS	AS	CL
<input type="checkbox"/>	<input type="checkbox"/>	<input type="checkbox"/>	<input type="checkbox"/>

2.信号输出(Signal output)

FG	RD	RD	LD
<input type="checkbox"/>	<input type="checkbox"/>	<input type="checkbox"/>	<input type="checkbox"/>

3.调速方式(Speed control mode)

PWM	TP	VC	RC	CS
<input type="checkbox"/>	<input type="checkbox"/>	<input type="checkbox"/>	<input type="checkbox"/>	<input type="checkbox"/>

Part Number	Voltage(V)	Current(A)	Power(W)	Speed(RPM)	Air flow(Q)	Pressure(P)	Noise(dBA)
产品编号	电压范围	额定电流	功率	转速	(CFM) 风量	m <sup>3</sup> /min (mmAq)风压 (In H <sub>2</sub> O)	噪音
RD18060B12L	12(7~14)	2.36	28.32	2500	373.03	10.55 17.03	0.67 56.38
RD18060B12M		3.25	39.00	2800	379.73	10.74 21.36	0.84 59.82
RD18060B24L	24(15~27)	1.18	28.32	2500	373.03	10.55 17.03	0.67 56.38
RD18060B24M		1.63	39.12	2800	379.73	10.74 21.36	0.84 59.82
RD18060B24H		2.16	51.84	3200	433.98	12.28 27.90	1.10 62.95
RD18060B24VH		2.84	68.16	3500	474.67	13.43 33.38	1.31 66.53
RD18060B24SH		3.60	86.40	3800	515.35	14.58 39.34	1.55 68.80
RD18060B48L	48(35~57)	0.59	28.32	2500	373.03	10.55 17.03	0.67 56.38
RD18060B48M		0.82	39.36	2800	379.73	10.74 21.36	0.84 59.82
RD18060B48H		1.08	51.84	3200	433.98	12.28 27.90	1.10 62.95
RD18060B48VH		1.42	68.16	3500	474.67	13.43 33.38	1.31 66.53
RD18060B48SH		1.80	86.40	3800	515.35	14.58 39.34	1.55 68.80

★ 如果您需要的转速或电压或功能不在这份清单上, 请与我们联系。  
If you want another rpm or voltage or functions which one is not in the list, please contact with our sales.

★ 提示1:功能的具体信息参照产品目录前页篇章。  
Notes1:The catalog have detail information in the front page for the functions.

★ 提示2:产品详细信息请参照承认书。  
Notes2:Product have a detail in the approval sheet.

★ 提示3:产品规格变更不另行通知。  
Notes3:Specifications are subject to change without notice.

★ 提示4:调速方式只能制作12V机型。  
Note4:Speed control mode only for 12V products.

## DC AXIAL FAN

### 200x200x60mm

#### RS20060 Series



外框材质:铝合金  
Frame:Aluminum  
扇叶材质:环保防火PC  
Impeller:Thermoplastic PC UL94-V0  
轴承结构:双滚珠  
Bearing system:2Ball  
单体风扇重量:1250g  
Unit Weight:1250g

DIMENSIONS DRAWING

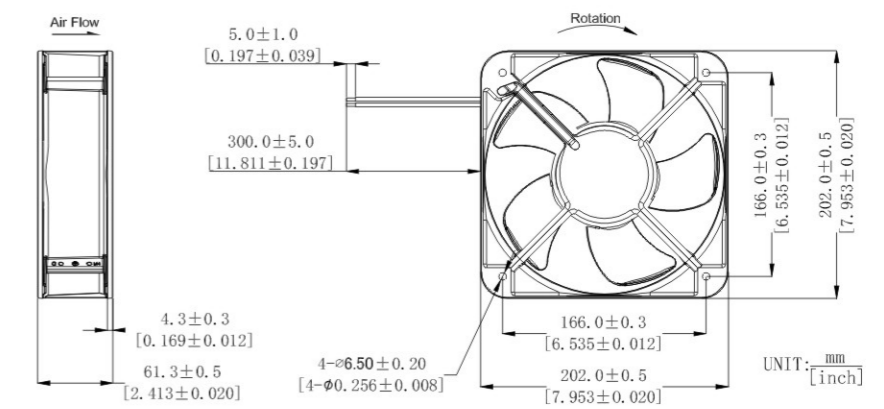

Fan Performance Curve

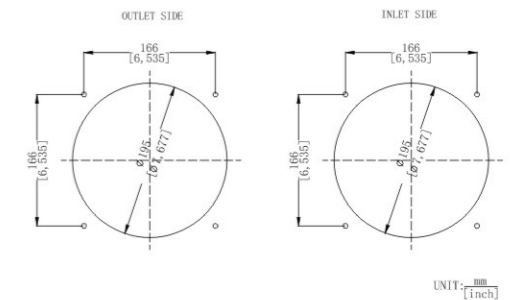
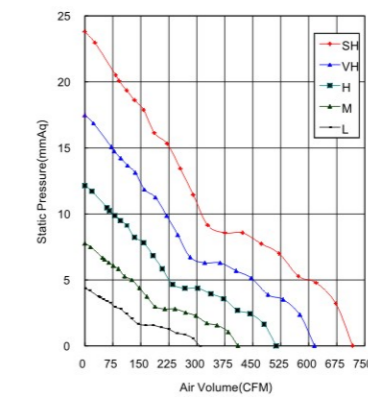

#### 可选的功能参照列表 (Available Functions)

1.马达保护(Motor protection)

RP	SS	AS	CL
<input type="checkbox"/>	<input type="checkbox"/>	<input type="checkbox"/>	<input type="checkbox"/>

2.信号输出(Signal output)

FG	RD	RD	LD
<input type="checkbox"/>	<input type="checkbox"/>	<input type="checkbox"/>	<input type="checkbox"/>

3.调速方式(Speed control mode)

PWM	TP	VC	RC	CS
<input type="checkbox"/>	<input type="checkbox"/>	<input type="checkbox"/>	<input type="checkbox"/>	<input type="checkbox"/>

Part Number	Voltage(V)	Current(A)	Power(W)	Speed(RPM)	Air flow(Q)	Pressure(P)	Noise(dBA)
产品编号	电压范围	额定电流	功率	转速	(CFM) 风量	m <sup>3</sup> /min (mmAq)风压 (In H <sub>2</sub> O)	噪音
RS20060B12L	12(7~14)	0.56	6.72	1500	307.65	8.71 4.37	0.17 44.5
RS20060B12M		1.16	13.92	2000	410.21	11.61 7.77	0.31 52.3
RS20060B12H		2.24	26.88	2500	512.76	14.51 12.14	0.48 58.6
RS20060B24L	24(15~27)	0.28	6.72	1500	307.65	8.71 4.37	0.17 44.5
RS20060B24M		0.58	13.92	2000	410.21	11.61 7.77	0.31 52.3
RS20060B24H		1.12	26.88	2500	512.76	14.51 12.14	0.48 58.6
RS20060B24VH		2.10	50.40	3000	615.31	17.41 17.48	0.69 64.8
RS20060B24SH		3.34	80.16	3500	717.86	20.32 23.80	0.94 69.1
RS20060B48L	48(35~57)	0.14	6.72	1500	307.65	8.71 4.37	0.17 44.5
RS20060B48M		0.29	13.92	2000	410.21	11.61 7.77	0.31 52.3
RS20060B48H		0.56	26.88	2500	512.76	14.51 12.14	0.48 58.6
RS20060B48VH		1.05	50.40	3000	615.31	17.41 17.48	0.69 64.8
RS20060B48SH		1.67	80.16	3500	717.86	20.32 23.80	0.94 69.1

★ 如果您需要的转速或电压或功能不在这份清单上, 请与我们联系。  
If you want another rpm or voltage or functions which one is not in the list, please contact with our sales.

★ 提示1:功能的具体信息参照产品目录前页篇章。  
Notes1:The catalog have detail information in the front page for the functions.

★ 提示2:产品详细信息请参照承认书。  
Notes2:Product have a detail in the approval sheet.

★ 提示3:产品规格变更不另行通知。  
Notes3:Specifications are subject to change without notice.

★ 提示4:调速方式只能制作12V机型。  
Note4:Speed control mode only for 12V products.

## DC AXIAL FAN

### 200x200x53mm

#### RS20053 Series



外框材质:环保防火PBT  
Frame:Thermoplastic PBT UL94-V0  
扇叶材质:环保防火PBT  
Impeller:Thermoplastic PBT UL94-V0  
轴承结构:双滚珠或长寿命含油结构  
Bearing system:2Ball or Long life sleeve  
单体风扇重量:1600g  
Unit Weight:1600g

DIMENSIONS DRAWING

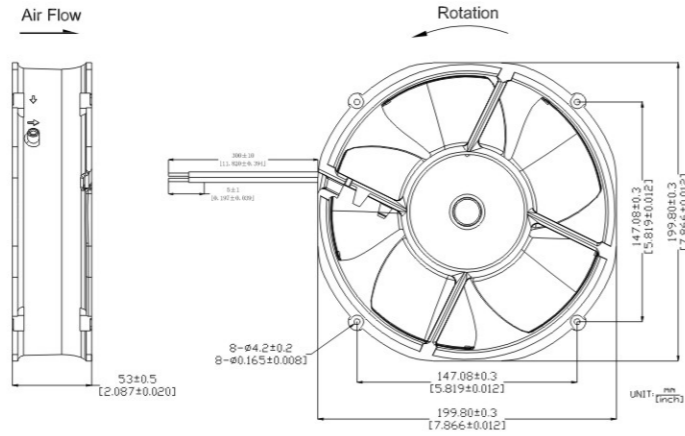

Fan Performance Curve

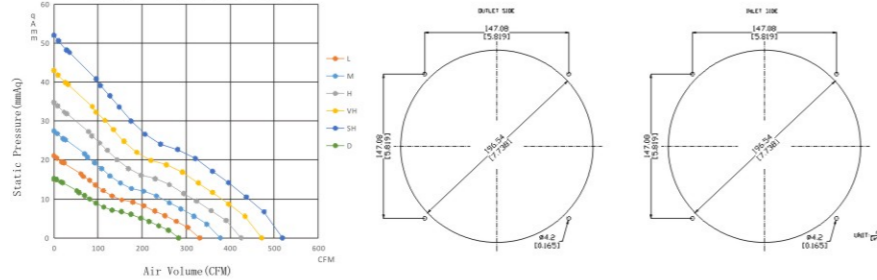

#### 可选的功能参照列表 (Available Functions)

1. 马达保护 (Motor protection)

RP	SS	AS	CL
<input type="checkbox"/>	<input type="checkbox"/>	<input type="checkbox"/>	<input type="checkbox"/>

2. 信号输出 (Signal output)

FG	RD	RD	LD
<input type="checkbox"/>	<input type="checkbox"/>	<input type="checkbox"/>	<input type="checkbox"/>

3. 调速方式 (Speed control mode)

PWM	TP	VC	RC	CS
<input type="checkbox"/>	<input type="checkbox"/>	<input type="checkbox"/>	<input type="checkbox"/>	<input type="checkbox"/>

Part Number	Voltage(V)	Current(A)	Power(W)	Speed(RPM)	Air flow(Q)	Pressure(P)	Noise(dBA)
产品编号	电压范围	额定电流	功率	转速	(CFM)风量	m <sup>3</sup> /min (mmAq)风压 (In H <sub>2</sub> O)	噪音
RS20053B12D	12(7~14)	1.55	18.5	3000	283.32	8.01	56.49
RS20053B12L		2.00	24.0	3500	330.54	9.53	60.12
RS20053B12M		2.70	32.4	4000	377.76	10.69	63.44
RS20053B12H		3.50	41.5	4500	424.98	12.02	66.66
RS20053B24D	24(15~27)	0.77	18.5	3000	283.32	8.01	56.49
RS20053B24L		1.00	24.0	3500	330.54	9.53	60.12
RS20053B24M		1.35	32.4	4000	377.76	10.69	63.44
RS20053B24H		1.73	41.5	4500	424.98	12.02	66.66
RS20053B24VH	48(35~57)	2.23	53.5	5000	472.20	13.36	68.47
RS20053B24SH		2.87	68.9	5500	519.42	14.69	71.89
RS20053B48D		0.39	18.5	3000	283.32	8.01	56.49
RS20053B48L		0.50	24.0	3500	330.54	9.53	60.12
RS20053B48M	48(35~57)	0.68	32.4	4000	377.76	10.69	63.44
RS20053B48H		0.86	41.5	4500	424.98	12.02	66.66
RS20053B48VH		1.12	53.5	5000	472.20	13.36	68.47
RS20053B48SH		1.43	68.9	5500	519.42	14.69	71.89

★ 如果您需要的转速或电压或功能不在这份清单上, 请与我们联系。  
If you want another rpm or voltage or functions which one is not in the list, please contact with our sales.

★ 提示1:功能的具体信息参照产品目录前页篇章。  
Notes1:The catalog have detail information in the front page for the functions.

★ 提示2:产品详细信息请参照承认书。  
Notes2:Product have a detail in the approval sheet.

★ 提示3:产品规格变更不另行通知。  
Notes3:Specifications are subject to change without notice.

★ 提示4:调速方式只能制作12V机型。  
Note4:Speed control mode only for 12V products.

## DC AXIAL FAN

### 200x200x70mm

#### RS20070 Series



外框材质:环保防火PBT  
Frame:Thermoplastic PBT UL94-V0  
扇叶材质:环保防火PBT  
Impeller:Thermoplastic PBT UL94-V0  
轴承结构:双滚珠  
Bearing system:2Ball  
单体风扇重量:1400g  
Unit Weight:1400g

DIMENSIONS DRAWING

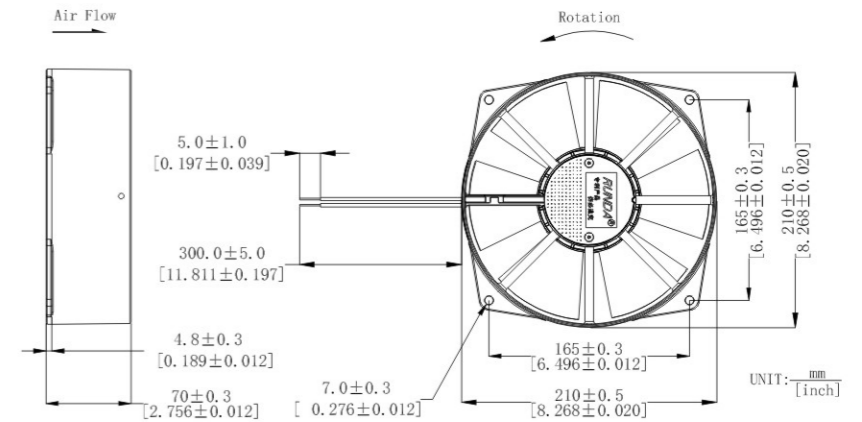

Fan Performance Curve

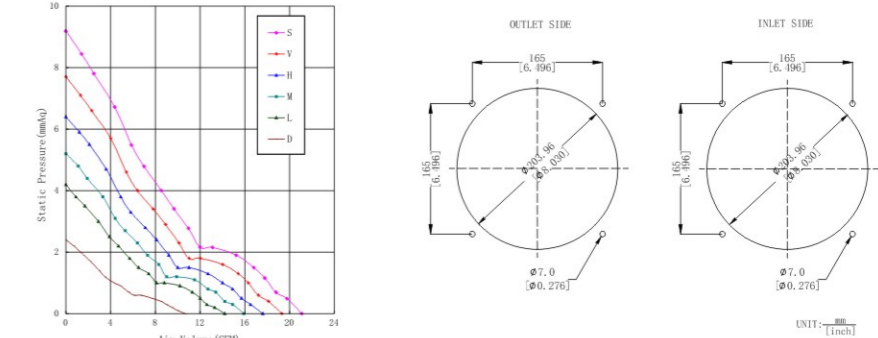

#### 可选的功能参照列表 (Available Functions)

1. 马达保护 (Motor protection)

RP	SS	AS	CL
<input type="checkbox"/>	<input type="checkbox"/>	<input type="checkbox"/>	<input type="checkbox"/>

2. 信号输出 (Signal output)

FG	RD	RD	LD
<input type="checkbox"/>	<input type="checkbox"/>	<input type="checkbox"/>	<input type="checkbox"/>

3. 调速方式 (Speed control mode)

PWM	TP	VC	RC	CS
<input type="checkbox"/>	<input type="checkbox"/>	<input type="checkbox"/>	<input type="checkbox"/>	<input type="checkbox"/>

Part Number	Voltage(V)	Current(A)	Power(W)	Speed(RPM)	Air flow(Q)	Pressure(P)	Noise(dBA)
产品编号	电压范围	额定电流	功率	转速	(CFM)风量	m <sup>3</sup> /min (mmAq)风压 (In H <sub>2</sub> O)	噪音
RS20070B12D	12(7~14)	0.70	8.40	1800	319.37	9.04	55.5
RS20070B12L		1.45	17.40	2300	408.08	11.55	62.7
RS20070B12M		2.40	28.80	2800	496.80	14.06	67.5
RS20070B24D	24(15~27)	0.35	8.40	1800	319.37	9.04	55.5
RS20070B24L		0.72	17.28	2300	408.08	11.55	62.7
RS20070B24M		1.20	28.80	2800	496.80	14.06	67.5
RS20070B24H		1.95	46.80	3300	585.51	18.09	71.7
RS20070B24VH	48(35~57)	3.20	76.80	3800	674.22	23.99	69.1
RS20070B48D		0.18	8.64	1800	319.37	9.04	55.5
RS20070B48L		0.36	17.28	2300	408.08	11.55	62.7
RS20070B48M		0.60	28.80	2800	496.80	14.06	67.5
RS20070B48H	48(35~57)	1.00	48.00	3300	585.51	16.57	71.7
RS20070B48VH		1.60	76.80	3800	674.22	19.08	69.1

★ 如果您需要的转速或电压或功能不在这份清单上, 请与我们联系。  
If you want another rpm or voltage or functions which one is not in the list, please contact with our sales.

★ 提示1:功能的具体信息参照产品目录前页篇章。  
Notes1:The catalog have detail information in the front page for the functions.

★ 提示2:产品详细信息请参照承认书。  
Notes2:Product have a detail in the approval sheet.

★ 提示3:产品规格变更不另行通知。  
Notes3:Specifications are subject to change without notice.

★ 提示4:调速方式只能制作12V机型。  
Note4:Speed control mode only for 12V products.

## DC AXIAL FAN

### 220x30mm

#### RS2230 Series





DIMENSIONS DRAWING

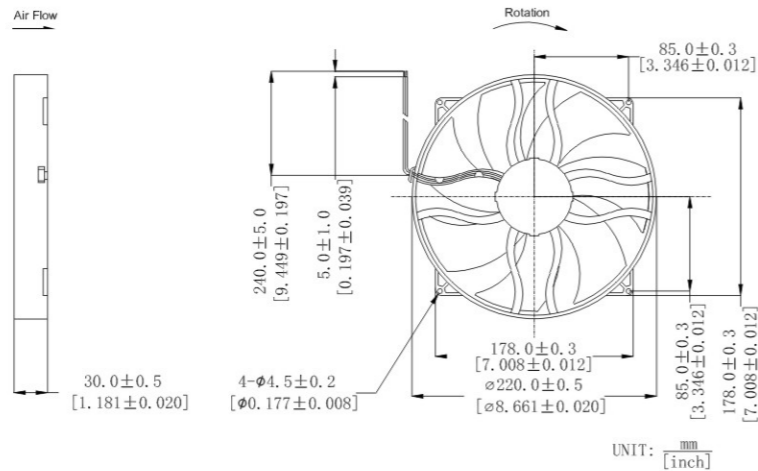

外框材质:环保防火PC  
 Frame:Thermoplastic PC UL94-V0  
 扇叶材质:环保防火PC  
 Impeller:Thermoplastic PC UL94-V0  
 轴承结构:双滚珠或长寿命含油结构  
 Bearing system:2Ball or Long life sleeve  
 单体风扇重量:250g  
 Unit Weight:250g

#### 可选的功能参照列表 (Available Functions)

1. 马达保护(Motor protection)

RP	SS	AS	CL
●	●	●	●

2. 信号输出(Signal output)

FG	RD	RD	LD
●	●	●	●

3. 调速方式(Speed control mode)

PWM	TP	VC	RC	CS
●	●	●	●	●

Fan Performance Curve

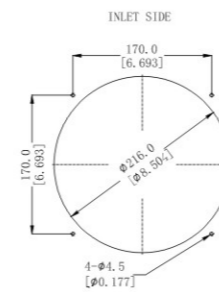
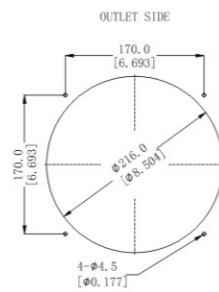
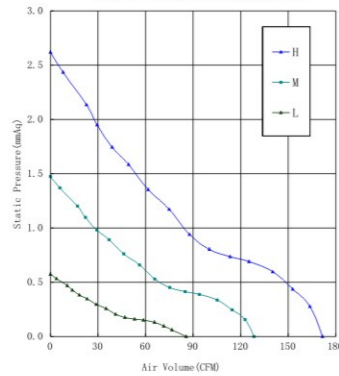

Part Number	Voltage(V)	Current(A)	Power(W)	Speed(RPM)	Air flow(Q)	Pressure(P)	Noise(dBA)
产品编号	电压范围	额定电流	功率	转速	(CFM) 风量	m <sup>3</sup> /min (mmAq)风压 (In H <sub>2</sub> O)	噪音
RS2230x12L	12(7~14)	0.36	4.32	800	85.60	2.42 0.65 0.03	28.5
RS2230x12M		0.52	6.24	1200	128.40	3.63 1.44 0.06	37.0
RS2230x12H		0.80	9.60	1600	171.20	4.84 2.60 0.10	44.5
RS2230x24L	24(15~27)	0.18	4.32	800	85.60	2.42 0.65 0.03	28.5
RS2230x24M		0.26	6.24	1200	128.40	3.63 1.44 0.06	37.0
RS2230x24H		0.40	9.60	1600	171.20	4.84 2.60 0.10	44.5
RS2230x48L	48(35~57)	0.09	4.32	800	85.60	2.42 0.65 0.03	28.5
RS2230x48M		0.13	6.24	1200	128.40	3.63 1.44 0.06	37.0
RS2230x48H		0.20	9.60	1600	171.20	4.84 2.60 0.10	44.5

★ 如果您需要的转速或电压或功能不在这份清单上, 请与我们联系。  
If you want another rpm or voltage or functions which one is not in the list, please contact with our sales.

★ 提示1:功能的具体信息参照产品目录前页篇章。  
Notes1: The catalog have detail information in the front page for the functions.

★ 提示2:产品详细信息请参照承认书。  
Notes2: Product have a detail in the approval sheet.

★ 提示3:产品规格变更不另行通知。  
Notes3: Specifications are subject to change without notice.

## DC AXIAL FAN

### 254x89mm

#### RD25489 Series





DIMENSIONS DRAWING

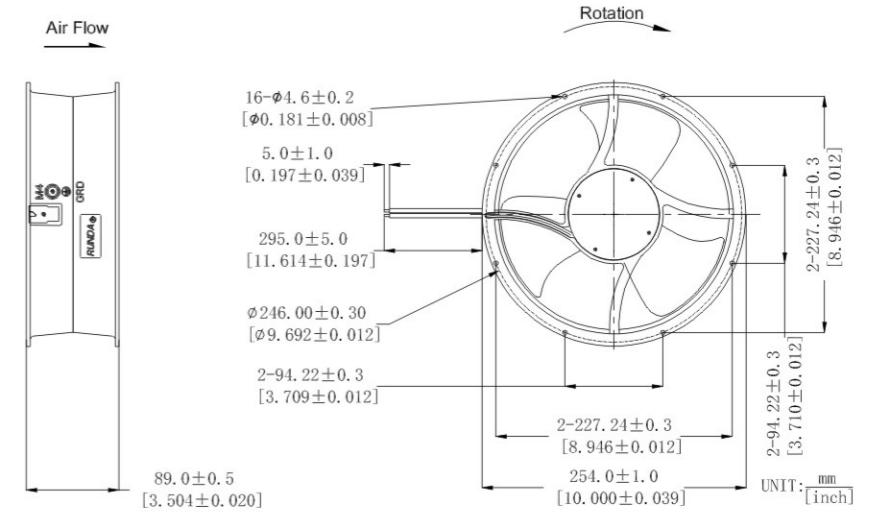

外框材质:铝合金  
 Frame:Aluminum  
 扇叶材质:环保防火PBT  
 Impeller:Thermoplastic PBT UL94-V0  
 轴承结构:双滚珠  
 Bearing system:2Ball  
 单体风扇重量:2410g  
 Unit Weight:2410g

#### 可选的功能参照列表 (Available Functions)

1. 马达保护(Motor protection)

RP	SS	AS	CL
●	●	●	●

2. 信号输出(Signal output)

FG	RD	RD	LD
●	●	●	●

3. 调速方式(Speed control mode)

PWM	TP	VC	RC	CS
●	●	●	●	●

Fan Performance Curve

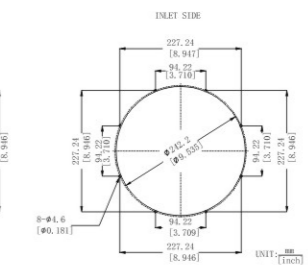
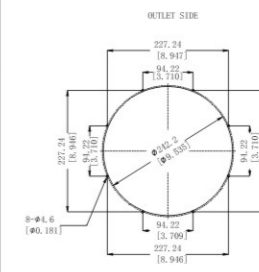
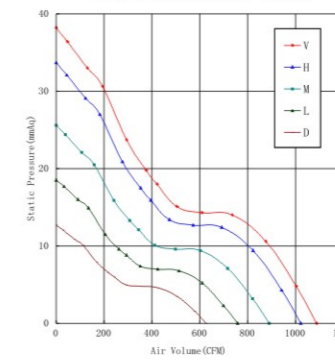

Part Number	Voltage(V)	Current(A)	Power(W)	Speed(RPM)	Air flow(Q)	Pressure(P)	Noise(dBA)
产品编号	电压范围	额定电流	功率	转速	(CFM) 风量	m <sup>3</sup> /min (mmAq)风压 (In H <sub>2</sub> O)	噪音
RD2589x12D	12(7~14)	2.20	26.4	1800	626.26	17.72 12.65 0.50	57.0
RD2589x24D		1.10	26.4	1800	626.26	17.72 12.65 0.50	57.0
RD2589x24L		1.50	36	2200	758.11	21.45 18.54 0.73	61.2
RD2589x24M	24(15~27)	2.66	63.84	2600	899.96	25.46 25.55 1.01	65.8
RD2589x24H		4.25	102	3000	1021.81	28.91 33.69 1.33	69.0
RD2589x48D		0.55	26.4	1800	626.26	17.72 12.65 0.50	57.0
RD2589x48L	48(35~57)	0.75	36	2200	758.11	21.45 18.54 0.73	61.2
RD2589x48M		1.33	63.84	2600	899.96	25.46 25.55 1.01	65.8
RD2589x48H		2.15	103.2	3000	1021.81	28.91 33.69 1.33	69.0
RD2589x48VH		2.35	112.8	3200	1088.73	30.80 38.26 1.51	70.6

★ 如果您需要的转速或电压或功能不在这份清单上, 请与我们联系。  
If you want another rpm or voltage or functions which one is not in the list, please contact with our sales.

★ 提示1:功能的具体信息参照产品目录前页篇章。  
Notes1: The catalog have detail information in the front page for the functions.

★ 提示2:产品详细信息请参照承认书。  
Notes2: Product have a detail in the approval sheet.

★ 提示3:产品规格变更不另行通知。  
Notes3: Specifications are subject to change without notice.

**25x12mm**  
**RB2512Series**  
UL US CE TÜV SÜD



DIMENSIONS DRAWING

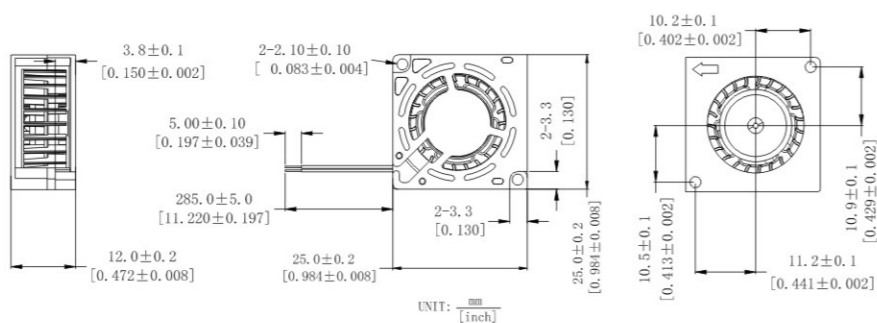

外框材质:环保防火PBT  
Frame:Thermoplastic PBT UL94-V0  
扇叶材质:环保防火PBT  
Impeller:Thermoplastic PBT UL94-V0  
轴承结构:双滚珠或长寿命含油结构  
Bearing system:2Ball or Long life sleeve  
单体风扇重量:12g  
Unit Weight:12g

可选的功能参照列表  
(Available Functions)

1.马达保护(Motor protection)

RP	SS	AS	CL
●	●	●	●

2.信号输出(Signal output)

FG	RD	RD	LD
●	●	●	●

3.调速方式(Speed control mode)

PWM	TP	VC	RC	CS
●	●	●	●	●

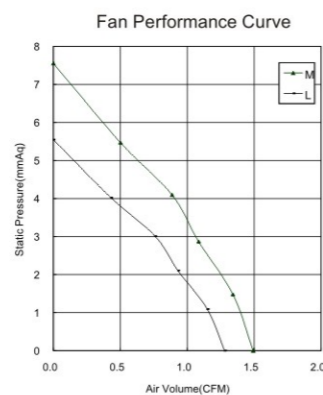

Part Number	Voltage(V)	Fre.(HZ)	Power(W)	Speed(RPM)	Air flow(Q)	Pressure(P)	Noise(dBA)		
产品编号	电压范围	额定电流	功率	转速	(CFM) 风量	m <sup>3</sup> /min (Mmaq)风压	(In H <sub>2</sub> O) 噪音		
RB2512x05L	5(4~6)	0.14	0.70	9000	1.28	5.55	4.37	0.17	28.3
RB2512x05M		0.16	0.80	10500	1.49	0.04	7.55	0.30	30.7

- ★ 如果您需要的转速或电压或功能不在这份清单上, 请与我们联系。  
If you want another rpm or voltage or functions which one is not in the list, please contact with our sales.
- ★ 提示1:功能的具体信息参照产品目录前页篇章。  
Notes1:The catalog have detail information in the front page for the functions.
- ★ 提示2:产品详细信息请参照承认书。  
Notes2:Product have a detail in the approval sheet.
- ★ 提示3:产品规格变更不另行通知。  
Notes3:Specifications are subject to change without notice.
- ★ 提示4:该款机型可制作相同转速的, 可在AC110V和AC220V双电压下使用。  
Note4:This model can be made in the same speed and used in AC110V, AC220V both.

**30x4mm**  
**RB3004Series**  
UL US CE TÜV SÜD

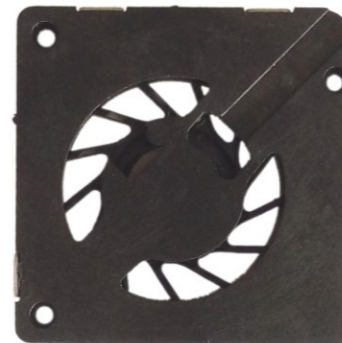

DIMENSIONS DRAWING

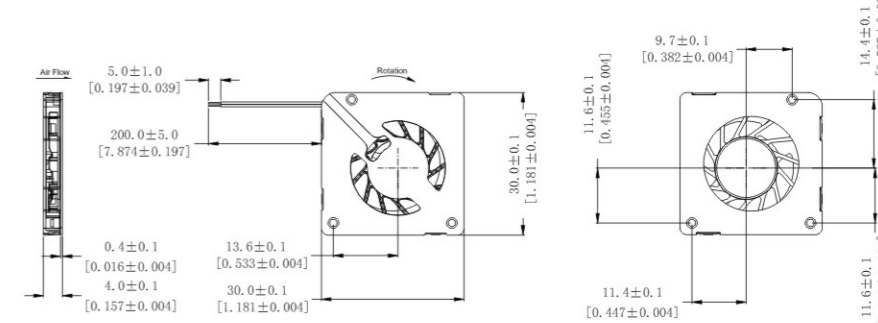

外框材质:环保防火PBT  
Frame:Thermoplastic PBT UL94-V0  
扇叶材质:环保防火PBT  
Impeller:Thermoplastic PBT UL94-V0  
轴承结构:长寿命含油结构  
Bearing system:Long life sleeve  
单体风扇重量:6g  
Unit Weight:6g

可选的功能参照列表  
(Available Functions)

1.马达保护(Motor protection)

RP	SS	AS	CL
●	●	●	●

2.信号输出(Signal output)

FG	RD	RD	LD
●	●	●	●

3.调速方式(Speed control mode)

PWM	TP	VC	RC	CS
○	○	○	○	○

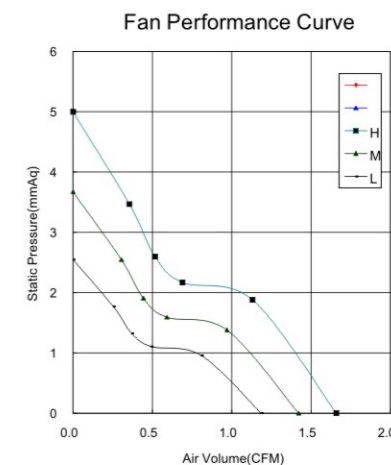

Part Number	Voltage (V)	Current (A)	Power (W)	Speed (RPM)	Air flow (Q)	Pressure (P)	Noise (dBA)		
产品编号	电压范围	额定电流	功率	转速	(CFM)风量	m <sup>3</sup> /min (mmAq)风压	(In H <sub>2</sub> O) 噪音		
RB3004x05L	5(4~6)	0.08	0.40	8500	1.18	0.03	2.55	0.10	24.3
RB3004x05M		0.10	0.50	9500	1.42	0.04	3.67	0.14	26.8
RB3004x05H		0.14	0.70	10000	1.66	0.05	5.00	0.20	29.2

- ★ 如果您需要的转速或电压或功能不在这份清单上, 请与我们联系。  
If you want another rpm or voltage or functions which one is not in the list, please contact with our sales.
- ★ 提示1:功能的具体信息参照产品目录前页篇章。  
Notes1:The catalog have detail information in the front page for the functions.
- ★ 提示2:产品详细信息请参照承认书。  
Notes2:Product have a detail in the approval sheet.
- ★ 提示3:产品规格变更不另行通知。  
Notes3:Specifications are subject to change without notice.

35x17mm

RB3517Series



DIMENSIONS DRAWING

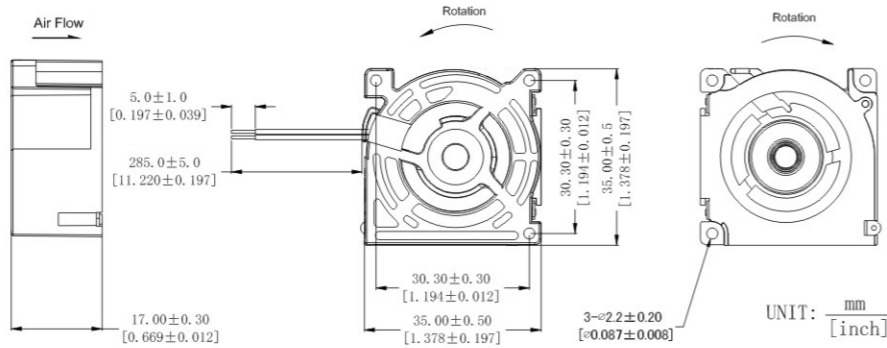

外框材质:环保防火PBT  
Frame:Thermoplastic PBT UL94-V0  
扇叶材质:环保防火PBT  
Impeller:Thermoplastic PBT UL94-V0  
轴承结构:双滚珠或长寿命含油结构  
Bearing system:2Ball or Long life sleeve  
单体风扇重量:24g  
Unit Weight:24g

可选的功能参照列表  
(Available Functions)

1.马达保护(Motor protection)

RP	SS	AS	CL
●	●	●	●

2.信号输出(Signal output)

FG	RD	RD	LD
●	●	●	●

3.调速方式(Speed control mode)

PWM	TP	VC	RC	CS
●	●	●	●	●

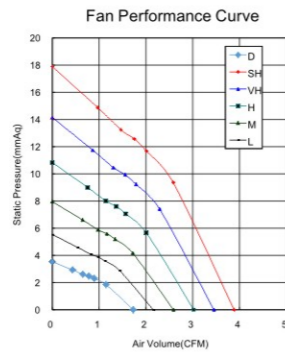

Part Number	Voltage(V)	Fre.(HZ)	Power(W)	Speed(RPM)	Air flow(Q)	Pressure(P)	Noise(dBA)
产品编号	电压范围	额定电流	功率	转速	(CFM) 风量	(Mmaq)风压	(In H,O) 噪音
RB3517x05D	5(4~6)	0.15	0.75	6000	1.73	3.53	33.5
RB3517x05L		0.24	1.20	6800	2.16	5.52	36.5
RB3517x05M		0.29	1.45	7400	3.02	10.82	37.9

★ 如果您需要的转速或电压或功能不在这份清单上, 请与我们联系。  
If you want another rpm or voltage or functions which one is not in the list, please contact with our sales.

★ 提示1:功能的具体信息参照产品目录前页篇章。  
Notes1:The catalog have detail information in the front page for the functions.

★ 提示2:产品详细信息请参照承认书。  
Notes2:Product have a detail in the approval sheet.

★ 提示3:产品规格变更不另行通知。  
Notes3:Specifications are subject to change without notice.

★ 提示4:该款机型可制作相同转速的, 可在AC110V和AC220V双电压下使用。  
Note4:This model can be made in the same speed and used in AC110V, AC220V both.

40x10mm

RB4010Series



DIMENSIONS DRAWING

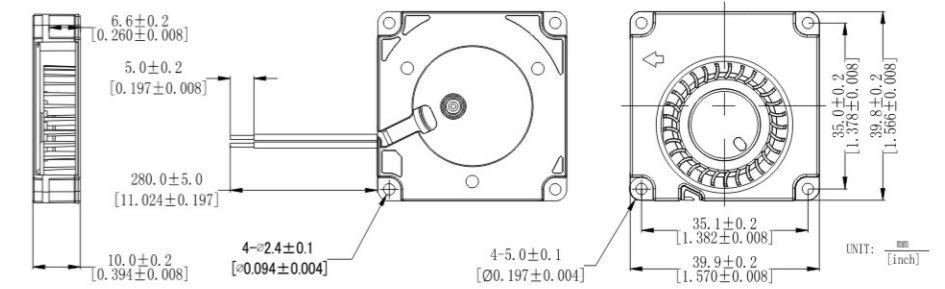

外框材质:环保防火PBT  
Frame:Thermoplastic PBT UL94-V0  
扇叶材质:环保防火PBT  
Impeller:Thermoplastic PBT UL94-V0  
轴承结构:双滚珠或长寿命含油结构  
Bearing system:2Ball or Long life sleeve  
单体风扇重量:26g  
Unit Weight:26g

可选的功能参照列表  
(Available Functions)

1.马达保护(Motor protection)

RP	SS	AS	CL
●	●	●	●

2.信号输出(Signal output)

FG	RD	RD	LD
●	●	●	●

3.调速方式(Speed control mode)

PWM	TP	VC	RC	CS
●				

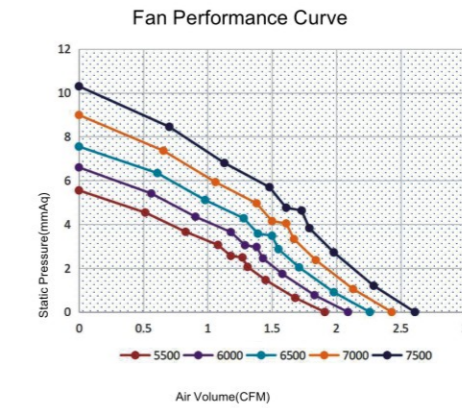

Part Number	Voltage(V)	Current(A)	Power(W)	Speed(RPM)	Air flow(Q)	Pressure(P)	Noise(dBA)
产品编号	电压范围	额定电流	功率	转速	(CFM) 风量	(mmAq)风压	(In H,O) 噪音
RB4010X05L	5(3.7~6)	0.12A	0.6	5700	2.56	9.88	35.2
RB4010X05M		0.16	0.8	6500	2.92	12.84	38.7
RB4010X05H		0.24	1.2	7500	3.37	17.1	40.3
RB4010X12M	12(7~14)	0.07A	0.84	6500	2.92	12.84	38.7
RB4010X12H		0.10A	1.2	7500	3.37	17.1	40.3
RB4010X12VH		0.12A	1.44	8300	3.73	20.94	43.5
RB4010X12SH	24(15~27)	0.13A	1.56	8800	3.96	23.54	45.2
RB4010X24H		0.07A	1.68	8300	3.73	20.94	43.5
RB4010X24SH		0.08A	1.92	8800	3.96	23.54	45.2

★ 如果您需要的转速或电压或功能不在这份清单上, 请与我们联系。  
If you want another rpm or voltage or functions which one is not in the list, please contact with our sales.

★ 提示1:功能的具体信息参照产品目录前页篇章。  
Notes1:The catalog have detail information in the front page for the functions.

★ 提示2:产品详细信息请参照承认书。  
Notes2:Product have a detail in the approval sheet.

★ 提示3:产品规格变更不另行通知。  
Notes3:Specifications are subject to change without notice.

★ 提示4:调速方式只能制作12V机型。  
Note4:Speed control mode only for 12V products.

40x20mm

RB4020Series



DIMENSIONS DRAWING

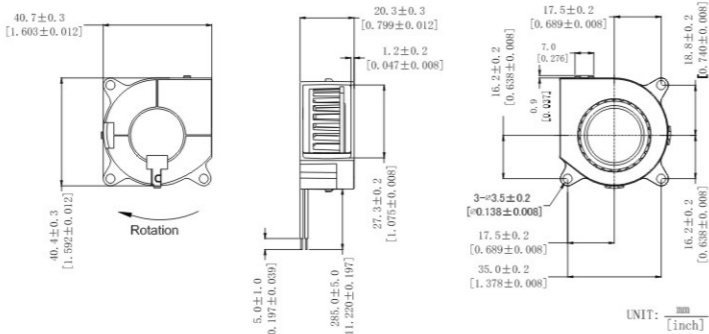

外框材质:环保防火PBT  
Frame:Thermoplastic PBT UL94-V0  
扇叶材质:环保防火PBT  
Impeller:Thermoplastic PBT UL94-V0  
轴承结构:双滚珠或长寿命含油结构  
Bearing system:2Ball or Long life sleeve  
单体风扇重量:26g  
Unit Weight:26g

可选的功能参照列表  
(Available Functions)

1.马达保护(Motor protection)

RP	SS	AS	CL
●	●	●	●

2.信号输出(Signal output)

FG	RD	RD	LD
●	●	●	●

3.调速方式(Speed control mode)

PWM	TP	VC	RC	CS
●	●	●	●	●

Fan Performance Curve

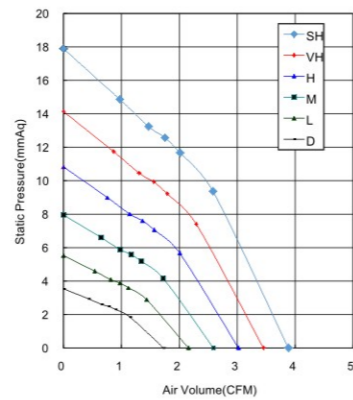

Part Number	Voltage(V)	Current(A)	Power(W)	Speed(RPM)	Air flow(Q)	Pressure(P)	Noise(dBA)		
产品编号	电压范围	额定电流	功率	转速	(CFM) 风量	m <sup>3</sup> /min (mmAq)风压 (In H <sub>2</sub> O)	噪音		
RB4020x05D	5(4~6)	0.10	0.50	4000	1.73	0.05	3.53	0.14	28.6
RB4020x05L		0.15	0.75	5000	2.16	0.06	5.52	0.22	30.5
RB4020x05M		0.20	1.00	6000	2.59	0.07	7.95	0.31	35.1
RB4020x05H		0.28	1.40	7000	3.02	0.09	10.82	0.43	38.6
RB4020x12D	12(7~14)	0.04	0.48	4000	1.73	0.05	3.53	0.14	28.6
RB4020x12L		0.06	0.72	5000	2.16	0.06	5.52	0.22	30.5
RB4020x12M		0.08	0.96	6000	2.59	0.07	7.95	0.31	35.1
RB4020x12H		0.12	1.44	7000	3.02	0.09	10.82	0.43	38.6
RB4020x12VH		0.17	2.04	8000	3.45	0.10	14.14	0.56	42.1
RB4020x12SH		0.24	2.88	9000	3.88	0.11	17.89	0.70	45.7
RB4020x24L	24(15~27)	0.04	0.96	5000	2.16	0.06	5.52	0.22	30.5
RB4020x24M		0.05	1.20	6000	2.59	0.07	7.95	0.31	35.1
RB4020x24H		0.06	1.44	7000	3.02	0.09	10.82	0.43	38.6
RB4020x24VH		0.09	2.16	8000	3.45	0.10	14.14	0.56	42.1
RB4020x24SH		0.12	2.88	9000	3.88	0.11	17.89	0.70	45.7

★ 如果您需要的转速或电压或功能不在这份清单上, 请与我们联系。  
If you want another rpm or voltage or functions which one is not in the list, please contact with our sales.

★ 提示1:功能的具体信息参照产品目录前页篇章。  
Notes1:The catalog have detail information in the front page for the functions.

★ 提示2:产品详细信息请参照承认书。  
Notes2:Product have a detail in the approval sheet.

★ 提示3:产品规格变更不另行通知。  
Notes3:Specifications are subject to change without notice.

★ 提示4:调速方式只能制作12V机型。  
Note4:Speed control mode only for 12V products.

50x15mm

RB5015Series



DIMENSIONS DRAWING

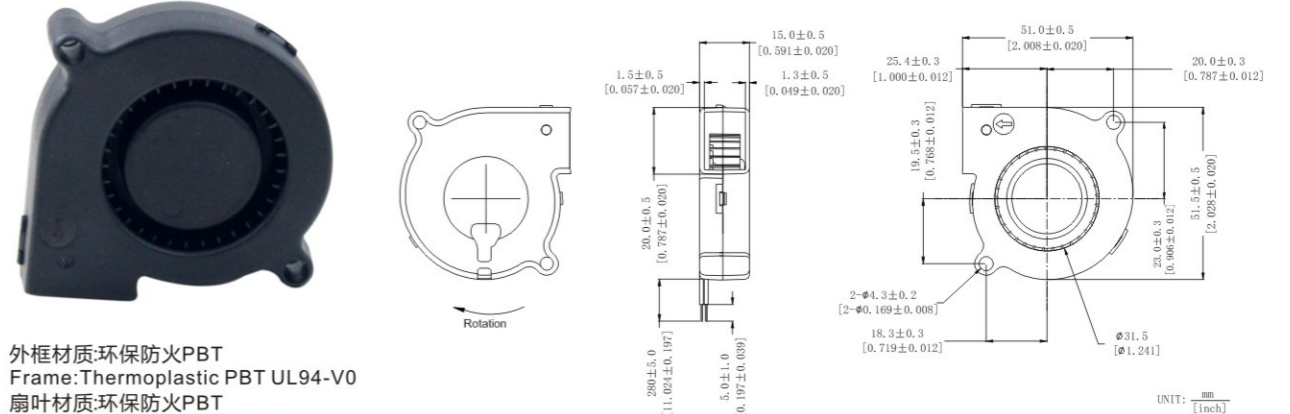

外框材质:环保防火PBT  
Frame:Thermoplastic PBT UL94-V0  
扇叶材质:环保防火PBT  
Impeller:Thermoplastic PBT UL94-V0  
轴承结构:双滚珠或长寿命含油结构  
Bearing system:2Ball or Long life sleeve  
单体风扇重量:26g  
Unit Weight:26g

可选的功能参照列表  
(Available Functions)

1.马达保护(Motor protection)

RP	SS	AS	CL
●	○	●	○

2.信号输出(Signal output)

FG	RD	RD	LD
●	●	○	○

3.调速方式(Speed control mode)

PWM	TP	VC	RC	CS
●	○	○	○	○

Fan Performance Curve

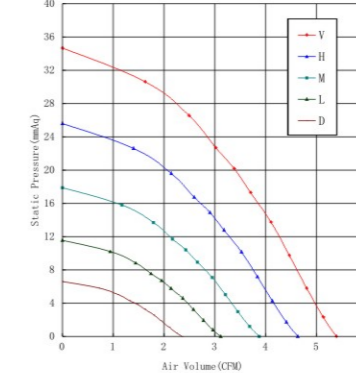

Part Number	Voltage(V)	Current(A)	Power(W)	Speed(RPM)	Air flow(Q)	Pressure(P)	Noise(dBA)		
产品编号	电压范围	额定电流	功率	转速	(CFM) 风量	m <sup>3</sup> /min (mmAq)风压 (In H <sub>2</sub> O)	噪音		
RB5015X05D	5(3.5~5.5)	0.1	0.5	3000	2.35	0.07	6.61	0.26	24.5
RB5015X05L		0.2	0.1	4000	3.11	0.09	11.56	0.46	31.20
RB5015X05M		0.32	1.6	5000	3.87	0.11	17.89	0.70	38.00
RB5015X05H		0.44	2.2	6000	4.63	0.13	25.61	1.01	39.80
RB5015X12D	12(7~14)	0.05	0.6	3000	2.35	0.07	6.61	0.26	24.5
RB5015X12L		0.1	1.2	4000	3.11	0.09	11.56	0.46	31.20
RB5015X12M		0.16	1.92	5000	3.87	0.11	17.89	0.70	38.00
RB5015X12H		0.22	2.64	6000	4.63	0.13	25.61	1.01	39.80
RB5015X12VH	24(15~27)	0.32	3.84	7000	5.39	0.15	34.67	1.36	42.40
RB5015X24M		0.08	1.92	5000	3.87	0.11	17.89	0.70	38.00
RB5015X24H		0.11	2.64	6000	4.63	0.13	25.61	1.01	39.80
RB5015X24VH		0.16	3.84	7000	5.39	0.15	34.67	1.36	42.40

★ 如果您需要的转速或电压或功能不在这份清单上, 请与我们联系。  
If you want another rpm or voltage or functions which one is not in the list, please contact with our sales.

★ 提示1:功能的具体信息参照产品目录前页篇章。  
Notes1:The catalog have detail information in the front page for the functions.

★ 提示2:产品详细信息请参照承认书。  
Notes2:Product have a detail in the approval sheet.

★ 提示3:产品规格变更不另行通知。  
Notes3:Specifications are subject to change without notice.

★ 提示4:调速方式只能制作12V机型。  
Note4:Speed control mode only for 12V products.

**50x15mm**  
**RB5015Series**  
UL US CE TUV SUD



外框材质:环保防火PBT  
Frame:Thermoplastic PBT UL94-V0  
扇叶材质:环保防火PBT  
Impeller:Thermoplastic PBT UL94-V0  
轴承结构:双滚珠或长寿命含油结构  
Bearing system:2Ball or Long life sleeve  
单体风扇重量:26g  
Unit Weight:26g

可选的功能参照列表  
(Available Functions)

1.马达保护(Motor protection)

RP	SS	AS	CL
<input type="checkbox"/>	<input type="checkbox"/>	<input type="checkbox"/>	<input type="checkbox"/>

2.信号输出(Signal output)

FG	RD	RD	LD
<input type="checkbox"/>	<input type="checkbox"/>	<input type="checkbox"/>	<input type="checkbox"/>

3.调速方式(Speed control mode)

PWM	TP	VC	RC	CS
<input type="checkbox"/>	<input type="checkbox"/>	<input type="checkbox"/>	<input type="checkbox"/>	<input type="checkbox"/>

Part Number	Voltage(V)	Current(A)	Power(W)	Speed(RPM)	Air flow(Q)	Pressure(P)	Noise(dBA)
产品编号	电压范围	额定电流	功率	转速	(CFM) 风量	(mmAq)风压 (In H <sub>2</sub> O)	噪音
RB5015X05L	5(4~6)	0.08	0.4	3700	2.7	0.08	25.81
RB5015X05M		0.14	0.7	4500	3.29	0.09	30.46
RB5015X05H		0.22	1.1	5200	3.8	0.11	34.39
RB5015X05VH	12(7~14)	0.34	1.7	6000	4.38	0.12	38.74
RB5015X12L		0.04	0.5	3700	2.7	0.08	25.81
RB5015X12M		0.07	0.8	4500	3.29	0.09	30.46
RB5015X12H	24(15~27)	0.11	1.3	5200	3.8	0.11	34.39
RB5015X12VH		0.17	2.1	6000	4.38	0.12	38.74
RB5015X12SH		0.25	3	6800	4.96	0.14	43.78
RB5015X24H	24(15~27)	0.05	1.2	5200	3.8	0.11	34.39
RB5015X24VH		0.08	1.9	6000	4.38	0.12	38.74
RB5015X24SH		0.13	3.1	6800	4.96	0.14	43.78

★ 如果您需要的转速或电压或功能不在这份清单上, 请与我们联系。  
If you want another rpm or voltage or functions which one is not in the list, please contact with our sales.

★ 提示1:功能的具体信息参照产品目录前页篇章。  
Notes1:The catalog have detail information in the front page for the functions.

★ 提示2:产品详细信息请参照承认书。  
Notes2:Product have a detail in the approval sheet.

★ 提示3:产品规格变更不另行通知。  
Notes3:Specifications are subject to change without notice.

★ 提示4:调速方式只能制作12V机型。  
Note4:Speed control mode only for 12V products.

DIMENSIONS DRAWING

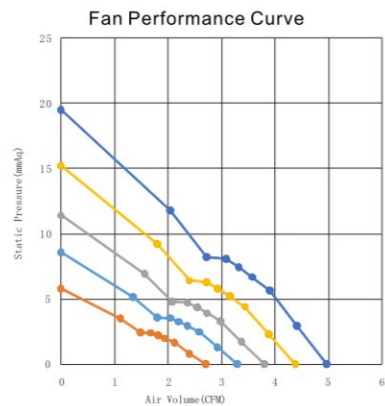
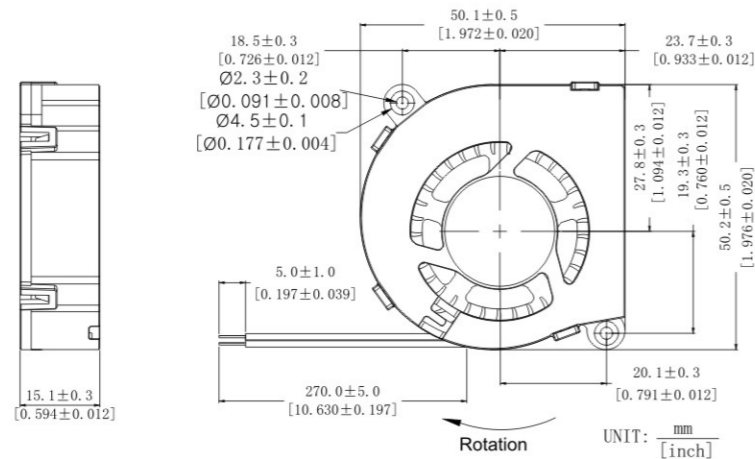

**50x20mm**  
**RB5020Series**  
UL US CE TUV SUD



外框材质:环保防火PBT  
Frame:Thermoplastic PBT UL94-V0  
扇叶材质:环保防火PBT  
Impeller:Thermoplastic PBT UL94-V0  
轴承结构:双滚珠或长寿命含油结构  
Bearing system:2Ball or Long life sleeve  
单体风扇重量:26g  
Unit Weight:26g

可选的功能参照列表  
(Available Functions)

1.马达保护(Motor protection)

RP	SS	AS	CL
<input type="checkbox"/>	<input type="checkbox"/>	<input type="checkbox"/>	<input type="checkbox"/>

2.信号输出(Signal output)

FG	RD	RD	LD
<input type="checkbox"/>	<input type="checkbox"/>	<input type="checkbox"/>	<input type="checkbox"/>

3.调速方式(Speed control mode)

PWM	TP	VC	RC	CS
<input type="checkbox"/>	<input type="checkbox"/>	<input type="checkbox"/>	<input type="checkbox"/>	<input type="checkbox"/>

DIMENSIONS DRAWING

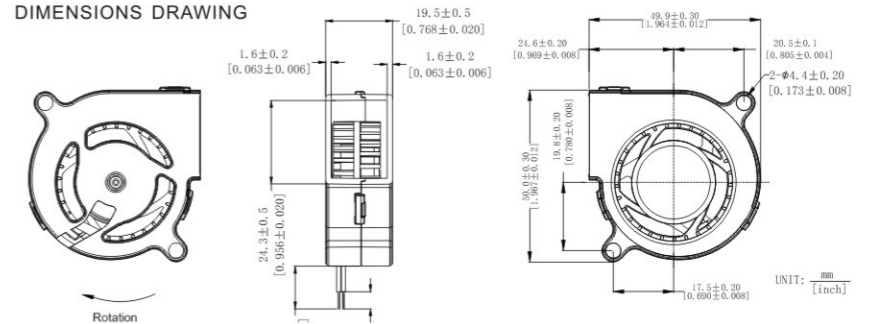

Fan Performance Curve

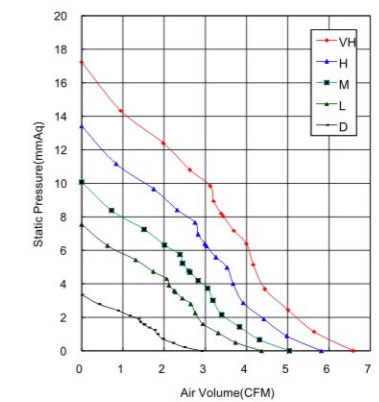

Part Number	Voltage(V)	Current(A)	Power(W)	Speed(RPM)	Air flow(Q)	Pressure(P)	Noise(dBA)
产品编号	电压范围	额定电流	功率	转速	(CFM) 风量	(mmAq)风压 (In H <sub>2</sub> O)	噪音
RB5020x05D	5(3~6)	0.13	0.65	3000	2.91	0.08	24.6
RB5020x05L		0.2	1	4500	4.36	0.12	34.0
RB5020x05M		0.29	1.45	5200	5.04	0.14	37.0
RB5020x05H	12(7~14)	0.28	1.4	6000	5.81	0.16	41.8
RB5020x12D		0.06	0.72	3000	2.91	0.08	24.6
RB5020x12L		0.09	1.08	4500	4.36	0.12	34.0
RB5020x12M	24(15~27)	0.13	1.56	5200	5.04	0.14	37.0
RB5020x12H		0.24	2.88	6000	5.81	0.16	41.8
RB5020x12VH		0.27	3.24	6800	6.59	0.19	45.0
RB5020x12SH	24(15~27)	0.32	3.84	7500	7.27	0.21	49.3
RB5020x24D		0.03	0.72	3000	2.91	0.08	24.6
RB5020x24L		0.04	0.96	4500	4.36	0.12	34.0
RB5020x24M	24(15~27)	0.06	1.44	5200	5.04	0.14	37.0
RB5020x24H		0.12	2.88	6000	5.81	0.16	41.8
RB5020x24VH		0.14	3.36	6800	6.59	0.19	45.0
RB5020x24SH	24(15~27)	0.17	4.08	7500	7.27	0.21	49.3

★ 如果您需要的转速或电压或功能不在这份清单上, 请与我们联系。  
If you want another rpm or voltage or functions which one is not in the list, please contact with our sales.

★ 提示1:功能的具体信息参照产品目录前页篇章。  
Notes1:The catalog have detail information in the front page for the functions.

★ 提示2:产品详细信息请参照承认书。  
Notes2:Product have a detail in the approval sheet.

★ 提示3:产品规格变更不另行通知。  
Notes3:Specifications are subject to change without notice.

★ 提示4:调速方式只能制作12V机型。  
Note4:Speed control mode only for 12V products.

60x25mm

RB6025Series



DIMENSIONS DRAWING

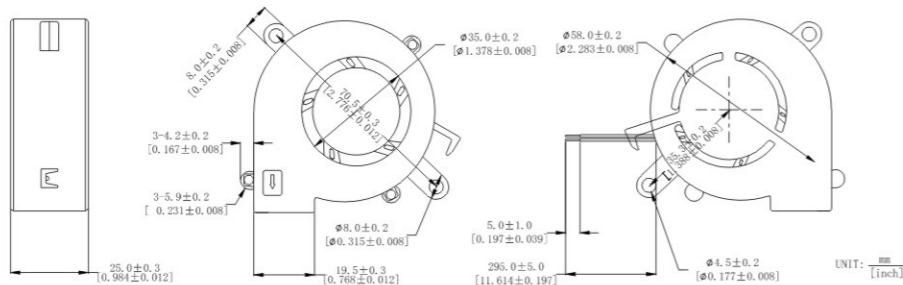

外框材质:环保防火PBT  
Frame:Thermoplastic PBT UL94-V0  
扇叶材质:环保防火PBT  
Impeller:Thermoplastic PBT UL94-V0  
轴承结构:双滚珠或长寿命含油结构  
Bearing system:2Ball or Long life sleeve  
单体风扇重量:55g  
Unit Weight:55g

可选的功能参照列表  
(Available Functions)

1.马达保护(Motor protection)

RP	SS	AS	CL
●	●	●	●

2.信号输出(Signal output)

FG	RD	RD	LD
●	●	●	●

3.调速方式(Speed control mode)

PWM	TP	VC	RC	CS
●	●	●	●	●

Fan Performance Curve

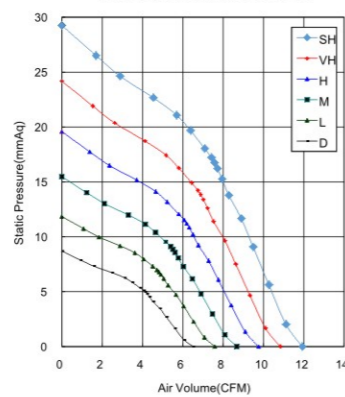

Part Number	Voltage(V)	Current(A)	Power(W)	Speed(RPM)	Air flow(Q)	Pressure(P)	Noise(dBA)		
产品编号	电压范围	额定电流	功率	转速	(CFM) 风量	m <sup>3</sup> /min (mmAq)风压 (In H <sub>2</sub> O)	噪音		
RB6025x05D	5(4-6)	0.20	1.00	3000	6.51	0.18	8.70	0.34	31.4
RB6025x05L		0.29	1.45	3500	7.59	0.21	11.84	0.47	35.2
RB6025x05M		0.36	1.80	4000	8.67	0.25	15.47	0.61	38.2
RB6025x12D	12(7-14)	0.08	0.96	3000	6.51	0.18	8.70	0.34	31.4
RB6025x12L		0.12	1.44	3500	7.59	0.21	11.84	0.47	35.2
RB6025x12M		0.15	1.80	4000	8.67	0.25	15.47	0.61	38.2
RB6025x12H		0.21	2.52	4500	9.76	0.28	19.58	0.77	41.2
RB6025x12VH		0.28	3.36	5000	10.84	0.31	24.17	0.95	45.0
RB6025x12SH		0.38	4.56	5500	11.93	0.34	29.25	1.15	47.8
RB6025x24L	24(15-27)	0.06	1.44	3500	7.59	0.21	11.84	0.47	35.2
RB6025x24M		0.08	1.92	4000	8.67	0.25	15.47	0.61	38.2
RB6025x24H		0.11	2.64	4500	9.76	0.28	19.58	0.77	41.2
RB6025x24VH		0.14	3.36	5000	10.84	0.31	24.17	0.95	45.0
RB6025x24SH		0.19	4.56	5500	11.93	0.34	29.25	1.15	47.8

★ 如果您需要的转速或电压或功能不在这份清单上, 请与我们联系。  
If you want another rpm or voltage or functions which one is not in the list, please contact with our sales.

★ 提示1:功能的具体信息参照产品目录前页篇章。  
Notes1:The catalog have detail information in the front page for the functions.

★ 提示2:产品详细信息请参照承认书。  
Notes2:Product have a detail in the approval sheet.

★ 提示3:产品规格变更不另行通知。  
Notes3:Specifications are subject to change without notice.

★ 提示4:调速方式只能制作12V机型。  
Note4:Speed control mode only for 12V products.

75x25mm

RB7525Series

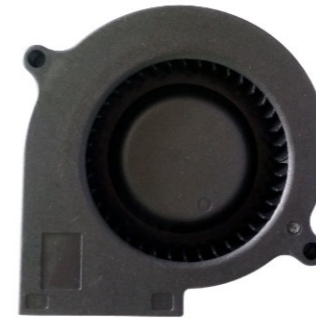

DIMENSIONS DRAWING

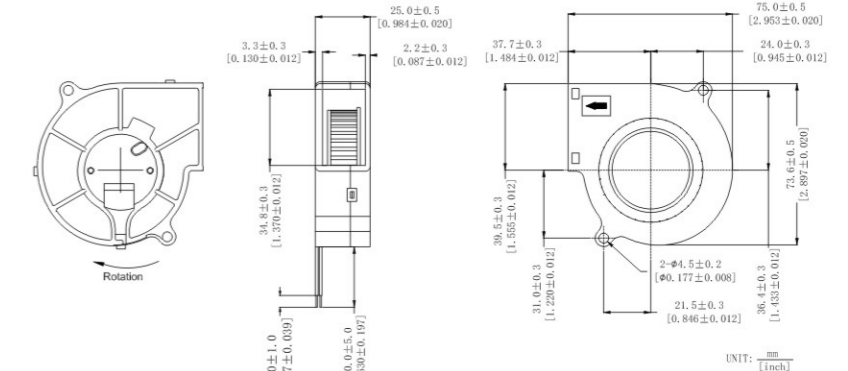

外框材质:环保防火PBT  
Frame:Thermoplastic PBT UL94-V0  
扇叶材质:环保防火PBT  
Impeller:Thermoplastic PBT UL94-V0  
轴承结构:双滚珠或长寿命含油结构  
Bearing system:2Ball or Long life sleeve  
单体风扇重量:70g  
Unit Weight:70g

可选的功能参照列表  
(Available Functions)

1.马达保护(Motor protection)

RP	SS	AS	CL
●	●	●	●

2.信号输出(Signal output)

FG	RD	RD	LD
●	●	●	●

3.调速方式(Speed control mode)

PWM	TP	VC	RC	CS
●	●	●	●	●

Fan Performance Curve

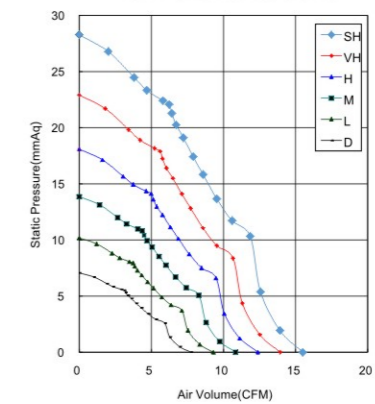

Part Number	Voltage(V)	Current(A)	Power(W)	Speed(RPM)	Air flow(Q)	Pressure(P)	Noise(dBA)		
产品编号	电压范围	额定电流	功率	转速	(CFM) 风量	m <sup>3</sup> /min (mmAq)风压 (In H <sub>2</sub> O)	噪音		
RB7525x05D	5(4-6)	0.24	1.20	2500	7.74	0.22	7.07	0.28	32.3
RB7525x05L		0.34	1.70	3000	9.29	0.26	10.18	0.40	38.1
RB7525x05M		0.50	2.50	3500	10.84	0.31	13.86	0.55	42.1
RB7525x12D	12(7-14)	0.10	1.20	2500	7.74	0.22	7.07	0.28	32.3
RB7525x12L		0.14	1.68	3000	9.29	0.26	10.18	0.40	38.1
RB7525x12M		0.21	2.52	3500	10.84	0.31	13.86	0.55	42.1
RB7525x12H		0.30	3.60	4000	12.39	0.35	18.10	0.71	45.6
RB7525x12VH		0.41	4.92	4500	13.94	0.39	22.91	0.90	49.1
RB7525x12SH		0.60	7.20	5000	15.48	0.44	28.28	1.11	51.8
RB7525x24L	24(15-27)	0.07	1.68	3000	9.29	0.26	10.18	0.40	38.1
RB7525x24M		0.11	2.64	3500	10.84	0.31	13.86	0.55	42.1
RB7525x24H		0.15	3.60	4000	12.39	0.35	18.10	0.71	45.6
RB7525x24VH		0.21	5.04	4500	13.94	0.39	22.91	0.90	49.1
RB7525x24SH		0.30	7.20	5000	15.48	0.44	28.28	1.11	51.8

★ 如果您需要的转速或电压或功能不在这份清单上, 请与我们联系。  
If you want another rpm or voltage or functions which one is not in the list, please contact with our sales.

★ 提示1:功能的具体信息参照产品目录前页篇章。  
Notes1:The catalog have detail information in the front page for the functions.

★ 提示2:产品详细信息请参照承认书。  
Notes2:Product have a detail in the approval sheet.

★ 提示3:产品规格变更不另行通知。  
Notes3:Specifications are subject to change without notice.

★ 提示4:调速方式只能制作12V机型。  
Note4:Speed control mode only for 12V products.

### 75x30mm

#### RB7530 Series

UL US CE TUV SUB



DIMENSIONS DRAWING

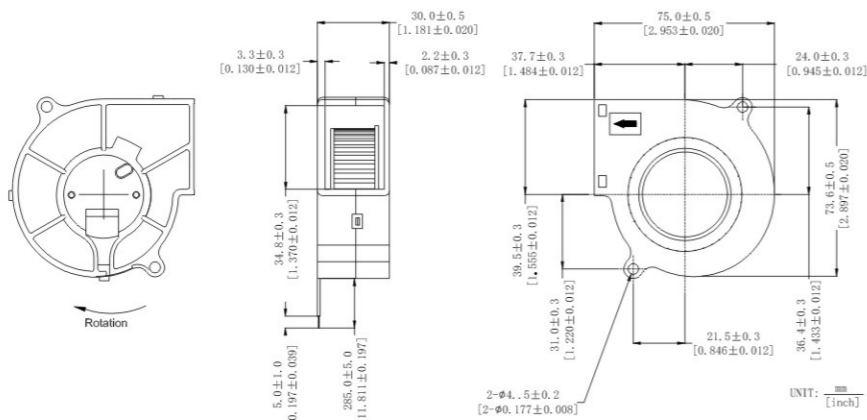

外框材质:环保防火PBT  
Frame:Thermoplastic PBT UL94-V0  
扇叶材质:环保防火PBT  
Impeller:Thermoplastic PBT UL94-V0  
轴承结构:双滚珠或长寿命含油结构  
Bearing system:2Ball or Long life sleeve  
单体风扇重量:78g  
Unit Weight:78g

可选的功能参照列表  
(Available Functions)

1.马达保护(Motor protection)

RP	SS	AS	CL
●	●	●	●

2.信号输出(Signal output)

FG	RD	RD	LD
●	●	●	●

3.调速方式(Speed control mode)

PWM	TP	VC	RC	CS
●	●	●	●	●

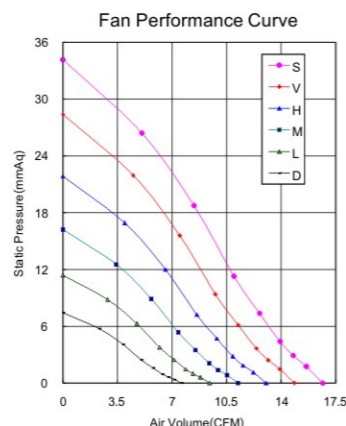

Part Number	Voltage(V)	Current(A)	Power(W)	Speed(RPM)	Air flow(Q)		Pressure(P)		Noise(dBA)	
产品编号	电压范围	额定电流	功率	转速	(CFM) 风量	m <sup>3</sup> /min	(mmAq)风压	(In H <sub>2</sub> O)	噪音	
RB7530X12D	12(7~14)	0.13	1.56	2000	7.61	0.22	7.44	0.29	28.5	
RB7530X12L		0.16	1.92	2500	9.42	0.27	11.41	0.45	32.5	
RB7530X12M		0.22	2.64	3000	11.23	0.32	16.22	0.64	36.1	
RB7530X12H		0.31	3.72	3500	13.04	0.37	21.87	0.86	39.5	
RB7530X12VH		0.36	4.32	4000	14.85	0.42	28.36	1.12	43.1	
RB7530X12SH		0.44	5.28	4500	16.66	0.47	35.71	1.41	45.8	
RB7530X24D		24(15~27)	0.06	1.44	2000	7.61	0.22	7.44	0.29	28.5
RB7530X24L			0.08	1.92	2500	9.42	0.27	11.41	0.45	32.5
RB7530X24M			0.11	2.64	3000	11.23	0.32	16.22	0.64	36.1
RB7530X24H			0.16	3.84	3500	13.04	0.37	21.87	0.86	39.5
RB7530X24VH	0.18		4.32	4000	14.85	0.42	28.36	1.12	43.1	
RB7530X24SH	0.22		5.28	4500	16.66	0.47	35.71	1.41	45.8	

★ 如果您需要的转速或电压或功能不在这份清单上, 请与我们联系。  
If you want another rpm or voltage or functions which one is not in the list, please contact with our sales.

★ 提示1:功能的具体信息参照产品目录前页篇章。  
Notes1:The catalog have detail information in the front page for the functions.

★ 提示2:产品详细信息请参照承认书。  
Notes2:Product have a detail in the approval sheet.

★ 提示3:产品规格变更不另行通知。  
Notes3:Specifications are subject to change without notice.

### 97x33mm

#### RB9733 Series

UL US CE TUV SUB



DIMENSIONS DRAWING

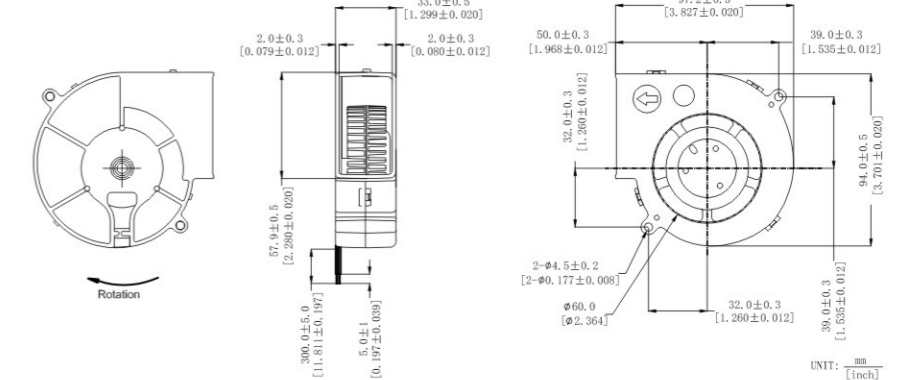

外框材质:环保防火PBT  
Frame:Thermoplastic PBT UL94-V0  
扇叶材质:环保防火PBT  
Impeller:Thermoplastic PBT UL94-V0  
轴承结构:双滚珠或长寿命含油结构  
Bearing system:2Ball or Long life sleeve  
单体风扇重量:166g  
Unit Weight:166g

可选的功能参照列表  
(Available Functions)

1.马达保护(Motor protection)

RP	SS	AS	CL
●	●	●	●

2.信号输出(Signal output)

FG	RD	RD	LD
●	●	●	●

3.调速方式(Speed control mode)

PWM	TP	VC	RC	CS
●	●	●	●	●

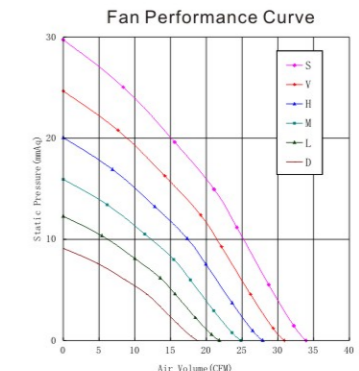

Part Number	Voltage(V)	Current(A)	Power(W)	Speed(RPM)	Air flow(Q)		Pressure(P)		Noise(dBA)	
产品编号	电压范围	额定电流	功率	转速	(CFM) 风量	m <sup>3</sup> /min	(mmAq)风压	(In H <sub>2</sub> O)	噪音	
RB9733X12D	12(7~14)	0.30	3.60	3000	18.79	0.53	9.10	0.36	40.2	
RB9733X12L		0.50	6.00	3500	21.82	0.62	12.27	0.48	45.3	
RB9733X12M		0.58	6.96	4000	24.85	0.70	15.93	0.63	47.0	
RB9733X12H		0.74	8.88	4500	27.88	0.79	20.05	0.79	49.9	
RB9733X12VH		0.96	11.52	5000	30.91	0.87	24.64	0.97	53.0	
RB9733X12SH		1.20	14.40	5500	33.94	0.96	29.70	1.17	54.5	
RB9733X24D		24(15~27)	0.15	3.60	3000	18.79	0.53	9.10	0.36	40.2
RB9733X24L			0.25	6.00	3500	21.82	0.62	12.27	0.48	45.3
RB9733X24M			0.29	6.96	4000	24.85	0.70	15.93	0.63	47.0
RB9733X24H			0.37	8.88	4500	27.88	0.79	20.05	0.79	49.9
RB9733X24VH	0.48		11.52	5000	30.91	0.87	24.64	0.97	53.0	
RB9733X24SH	0.60		14.40	5500	33.94	0.96	29.70	1.17	54.5	
RB9733X48D	48(35~57)	0.07	3.36	3000	18.79	0.53	9.10	0.36	40.2	
RB9733X48L		0.12	5.76	3500	21.82	0.62	12.27	0.48	45.3	
RB9733X48M		0.14	6.72	4000	24.85	0.70	15.93	0.63	47.0	
RB9733X48H		0.18	8.64	4500	27.88	0.79	20.05	0.79	49.9	
RB9733X48VH		0.24	11.52	5000	30.91	0.87	24.64	0.97	53.0	
RB9733X48SH		0.30	14.40	5500	33.94	0.96	29.70	1.17	54.5	

★ 如果您需要的转速或电压或功能不在这份清单上, 请与我们联系。  
If you want another rpm or voltage or functions which one is not in the list, please contact with our sales.

★ 提示1:功能的具体信息参照产品目录前页篇章。  
Notes1:The catalog have detail information in the front page for the functions.

★ 提示2:产品详细信息请参照承认书。  
Notes2:Product have a detail in the approval sheet.

★ 提示3:产品规格变更不另行通知。  
Notes3:Specifications are subject to change without notice.

120x32mm  
RB1232 Series



DIMENSIONS DRAWING

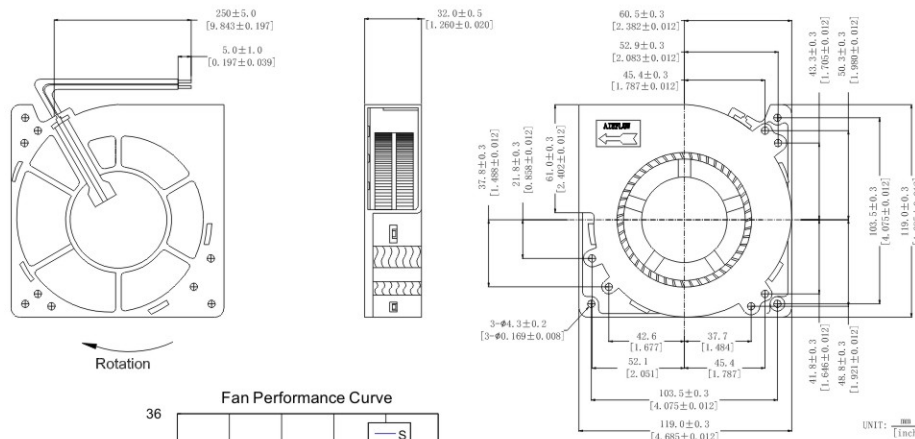

外框材质:环保防火PBT  
Frame:Thermoplastic PBT UL94-V0  
扇叶材质:环保防火PBT  
Impeller:Thermoplastic PBT UL94-V0  
轴承结构:双滚珠或长寿命含油结构  
Bearing system:2Ball or Long life sleeve  
单体风扇重量:260g  
Unit Weight:260g

可选的功能参照列表  
(Available Functions)

1.马达保护(Motor protection)

RP	SS	AS	CL
●	●	●	●

2.信号输出(Signal output)

FG	RD	RD	LD
●	●	●	●

3.调速方式(Speed control mode)

PWM	TP	VC	RC	CS
●	●	●	●	●

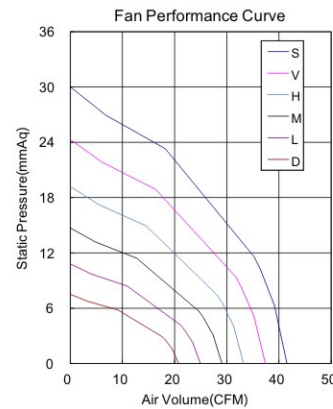

Part Number	Voltage(V)	Current(A)	Power(W)	Speed(RPM)	Air flow(Q)	Pressure(P)	Noise(dBA)
产品编号	电压范围	额定电流	功率	转速	(CFM) 风量	m <sup>3</sup> /min (mmAq)风压 (In H <sub>2</sub> O)	噪音
RB1232X12D	12(7~14)	0.44	5.28	2000	20.76	0.59 7.50 0.30	40.8
RB1232X12L		0.56	6.72	2400	24.92	0.70 10.80 0.43	45.5
RB1232X12M		0.92	11.04	2800	29.07	0.82 14.70 0.58	48.5
RB1232X12H		1.00	12.00	3200	33.22	0.94 19.20 0.76	51.4
RB1232X12VH		1.10	13.20	3600	37.38	1.06 24.30 0.96	54.3
RB1232X12SH		1.34	16.08	4000	41.53	1.17 30.00 1.18	59.0
RB1232X24D	24(15~27)	0.20	4.80	2000	20.76	0.59 7.50 0.30	40.8
RB1232X24L		0.28	6.72	2400	24.92	0.70 10.80 0.43	45.5
RB1232X24M		0.46	11.04	2800	29.07	0.82 14.70 0.58	48.5
RB1232X24H		0.50	12.00	3200	33.22	0.94 19.20 0.76	51.4
RB1232X24VH		0.55	13.20	3600	37.38	1.06 24.30 0.96	54.3
RB1232X24SH		0.67	16.08	4000	41.53	1.17 30.00 1.18	59.0
RB1232X48L	48(35~57)	0.14	6.72	2400	24.92	0.70 10.80 0.43	45.5
RB1232X48M		0.23	11.04	2800	29.07	0.82 14.70 0.58	48.5
RB1232X48H		0.25	12.00	3200	33.22	0.94 19.20 0.76	51.4
RB1232X48VH		0.27	12.96	3600	37.38	1.06 24.30 0.96	54.3
RB1232X48SH		0.33	15.84	4000	41.53	1.17 30.00 1.18	59.0

★如果您需要的转速或电压或功能不在这份清单上, 请与我们联系。  
If you want another rpm or voltage or functions which one is not in the list, please contact with our sales.

★提示1:功能的具体信息参照产品目录前页篇章。  
Notes1:The catalog have detail information in the front page for the functions.

★提示2:产品详细信息请参照承认书。  
Notes2:Product have a detail in the approval sheet.

★提示3:产品规格变更不另行通知。  
Notes3:Specifications are subject to change without notice.

60\*60\*25mm  
RT6025 Series



DIMENSIONS DRAWING

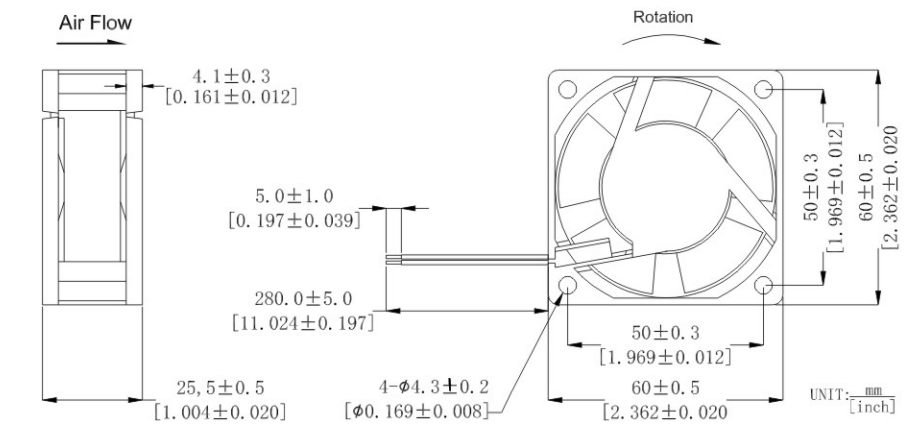

外框材质:环保防火PBT  
Frame:Thermoplastic PBT UL94-V0  
扇叶材质:环保防火PBT  
Impeller:Thermoplastic PBT UL94-V0  
轴承结构:双滚珠或长寿命含油结构  
Bearing system:2Ball or Long life sleeve  
单体风扇重量:55g  
Unit Weight:55g

可选的功能参照列表  
(Available Functions)

1.马达保护(Motor protection)

RP	SS	AS	CL
○	●	●	●

2.信号输出(Signal output)

FG	RD	RD	LD
●	●	●	●

3.调速方式(Speed control mode)

PWM	TP	VC	RC	CS
●	●	●	●	●

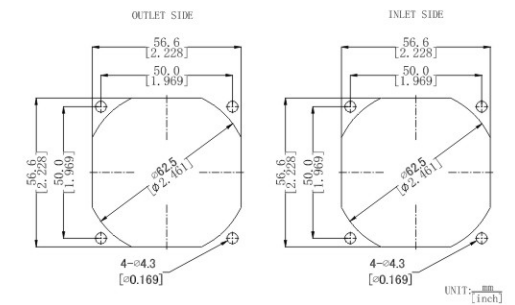
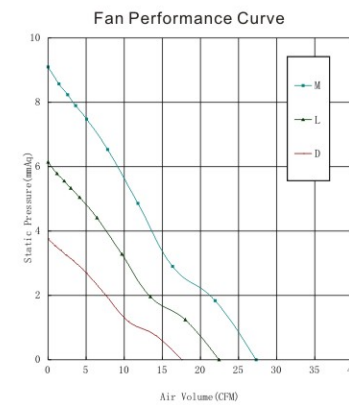

Part Number	Voltage(V)	Fre. (HZ)	Power(W)	Speed(RPM)	Air flow(Q)	Pressure(P)	Noise(dBA)
产品编号	电压范围	频率范围	功率	转速	(CFM) 风量	m <sup>3</sup> /min (Mmaq)风压 (In H <sub>2</sub> O)	噪音
RT6025x11D	AC110(80~120)	45~65	3.0	3500	17.56	0.50 3.76 0.15	30.8
RT6025x11L		45~65	3.8	4500	22.43	0.63 6.14 0.24	35.2
RT6025x11M		45~65	4.2	5500	27.32	0.77 9.10 0.36	39.5
RT6025x22D	AC220(120~240)	45~65	3.0	3500	17.56	0.50 3.76 0.15	30.8
RT6025x22L		45~65	3.8	4500	22.43	0.63 6.14 0.24	35.2
RT6025x22M		45~65	4.2	5500	27.32	0.77 9.10 0.36	39.5

★如果您需要的转速或电压或功能不在这份清单上, 请与我们联系。  
If you want another rpm or voltage or functions which one is not in the list, please contact with our sales.

★提示1:功能的具体信息参照产品目录前页篇章。  
Notes1:The catalog have detail information in the front page for the functions.

★提示2:产品详细信息请参照承认书。  
Notes2:Product have a detail in the approval sheet.

★提示3:产品规格变更不另行通知。  
Notes3:Specifications are subject to change without notice.

★提示4:该款机型可制作相同转速的, 可在AC110V和AC220V双电压下使用。  
Note4:This model can be made in the same speed and used in AC110V, AC220V both.

**60\*60\*38mm**  
**RT6038 Series**  
**CE**

DIMENSIONS DRAWING



外框材质:环保防火PBT  
Frame:Thermoplastic PBT UL94-V0  
扇叶材质:环保防火PBT  
Impeller:Thermoplastic PBT UL94-V0  
轴承结构:双滚珠或长寿命含油结构  
Bearing system:2Ball or Long life sleeve  
单体风扇重量:106g  
Unit Weight:106g

可选的功能参照列表  
(Available Functions)

1.马达保护(Motor protection)

RP	SS	AS	CL
<input type="checkbox"/>	<input type="checkbox"/>	<input type="checkbox"/>	<input type="checkbox"/>

2.信号输出(Signal output)

FG	RD	RD	LD
<input type="checkbox"/>	<input type="checkbox"/>	<input type="checkbox"/>	<input type="checkbox"/>

3.调速方式(Speed control mode)

PWM	TP	VC	RC	CS
<input type="checkbox"/>	<input type="checkbox"/>	<input type="checkbox"/>	<input type="checkbox"/>	<input type="checkbox"/>

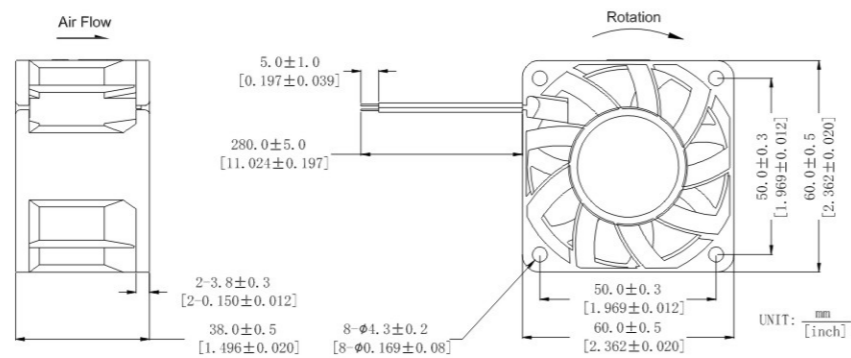

Fan Performance Curve

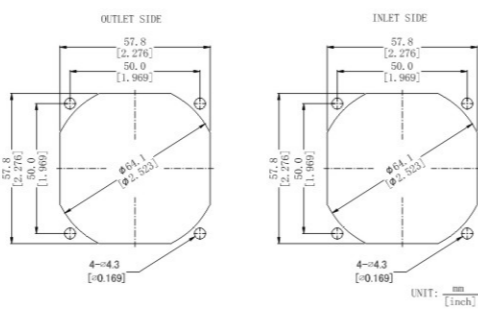
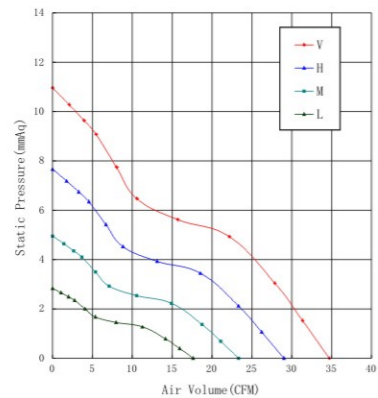

Part Number	Voltage(V)	Fre.(HZ)	Power(W)	Speed(RPM)	Air flow(Q)	Pressure(P)	Noise(dBA)		
产品编号	电压范围	频率范围	功率	转速	(CFM) 风量	m <sup>3</sup> /min (Mmaq)风压 (In H <sub>2</sub> O)	噪音		
RT6038x11L	110(80~120)	45~65	3.0	3000	17.63	0.50	2.83	0.11	30.8
RT6038x11M		45~65	3.6	4000	23.32	0.66	4.95	0.19	36.9
RT6038x11H		45~65	4.4	5000	29.01	0.82	7.66	0.30	43.0
RT6038x11VH		45~65	5.0	6000	34.70	0.98	10.96	0.43	47.4
RT6038x22L	220(120~240)	45~65	3.0	3000	17.63	0.50	2.83	0.11	30.8
RT6038x22M		45~65	3.6	4000	23.32	0.66	4.95	0.19	36.9
RT6038x22H		45~65	4.4	5000	29.01	0.82	7.66	0.30	43.0
RT6038x22VH		45~65	5.0	6000	34.70	0.98	10.96	0.43	47.4

- ★ 如果您需要的转速或电压或功能不在这份清单上, 请与我们联系。  
If you want another rpm or voltage or functions which one is not in the list, please contact with our sales.
- ★ 提示1:功能的具体信息参照产品目录前页篇章。  
Notes1:The catalog have detail information in the front page for the functions.
- ★ 提示2:产品详细信息请参照承认书。  
Notes2:Product have a detail in the approval sheet.
- ★ 提示3:产品规格变更不另行通知。  
Notes3:Specifications are subject to change without notice.
- ★ 提示4:该款机型可制作相同转速的, 可在AC110V和AC220V双电压下使用。  
Note4:This model can be made in the same speed and used in AC110V, AC220V both.

**80\*80\*25mm**  
**RT8025 Series**  
**CE**

DIMENSIONS DRAWING



外框材质:环保防火PBT  
Frame:Thermoplastic PBT UL94-V0  
扇叶材质:环保防火PBT  
Impeller:Thermoplastic PBT UL94-V0  
轴承结构:双滚珠或长寿命含油结构  
Bearing system:2Ball or Long life sleeve  
单体风扇重量:54g  
Unit Weight:54g

可选的功能参照列表  
(Available Functions)

1.马达保护(Motor protection)

RP	SS	AS	CL
<input type="checkbox"/>	<input type="checkbox"/>	<input type="checkbox"/>	<input type="checkbox"/>

2.信号输出(Signal output)

FG	RD	RD	LD
<input type="checkbox"/>	<input type="checkbox"/>	<input type="checkbox"/>	<input type="checkbox"/>

3.调速方式(Speed control mode)

PWM	TP	VC	RC	CS
<input type="checkbox"/>	<input type="checkbox"/>	<input type="checkbox"/>	<input type="checkbox"/>	<input type="checkbox"/>

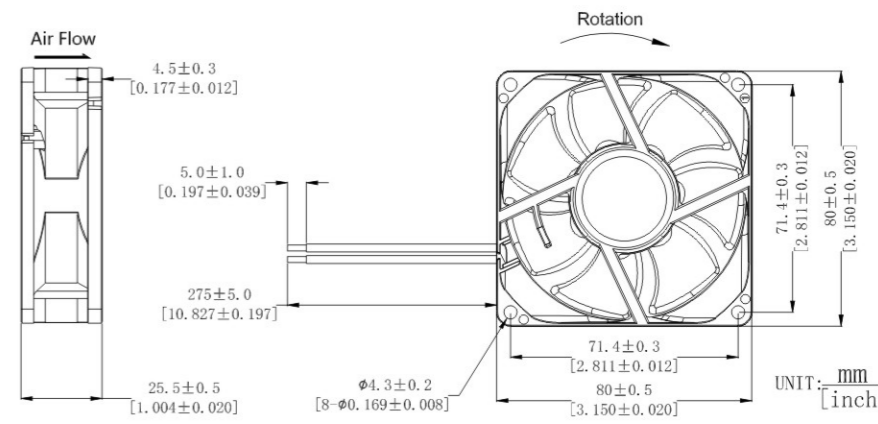

Fan Performance Curve

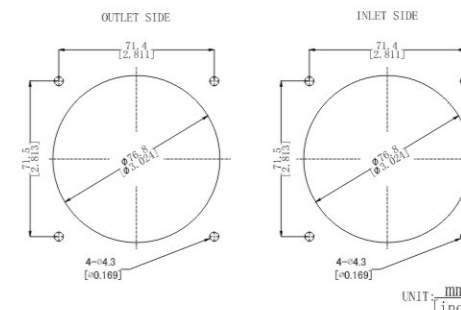
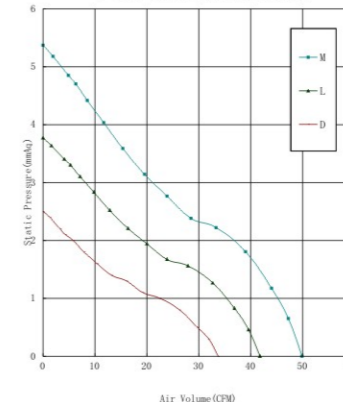

Part Number	Voltage(V)	Fre.(HZ)	Power(W)	Speed(RPM)	Air flow(Q)	Pressure(P)	Noise(dBA)		
产品编号	电压范围	频率范围	功率	转速	(CFM) 风量	m <sup>3</sup> /min (Mmaq)风压 (In H <sub>2</sub> O)	噪音		
RT8025x11D	110(80~120)	45~65	3.0	2400	34.86	0.99	2.45	0.10	29.9
RT8025x11L		45~65	3.8	3000	43.23	1.22	3.77	0.15	34.8
RT8025x11M		45~65	4.2	3600	51.59	1.46	5.37	0.21	38.3
RT8025x22D	220(120~240)	45~65	3.0	2400	34.86	0.99	2.45	0.10	29.9
RT8025x22L		45~65	3.8	3000	43.23	1.22	3.77	0.15	34.8
RT8025x22M		45~65	4.2	3600	51.59	1.46	5.37	0.21	38.3

- ★ 如果您需要的转速或电压或功能不在这份清单上, 请与我们联系。  
If you want another rpm or voltage or functions which one is not in the list, please contact with our sales.
- ★ 提示1:功能的具体信息参照产品目录前页篇章。  
Notes1:The catalog have detail information in the front page for the functions.
- ★ 提示2:产品详细信息请参照承认书。  
Notes2:Product have a detail in the approval sheet.
- ★ 提示3:产品规格变更不另行通知。  
Notes3:Specifications are subject to change without notice.
- ★ 提示4:该款机型可制作相同转速的, 可在AC110V和AC220V双电压下使用。  
Note4:This model can be made in the same speed and used in AC110V, AC220V both.

# EC (AC TO DC) FAN

## 80\*80\*32mm RT8032 Series CE



外框材质:环保防火PBT  
Frame:Thermoplastic PBT UL94-V0  
扇叶材质:环保防火PBT  
Impeller:Thermoplastic PBT UL94-V0  
轴承结构:双滚珠或长寿命含油结构  
Bearing system:2Ball or Long life sleeve  
单体风扇重量:95g  
Unit Weight:95g

DIMENSIONS DRAWING

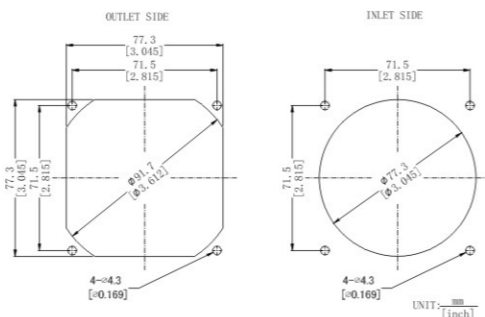
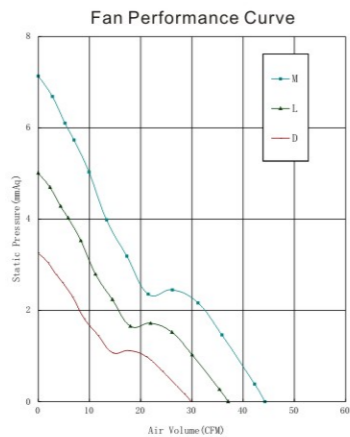
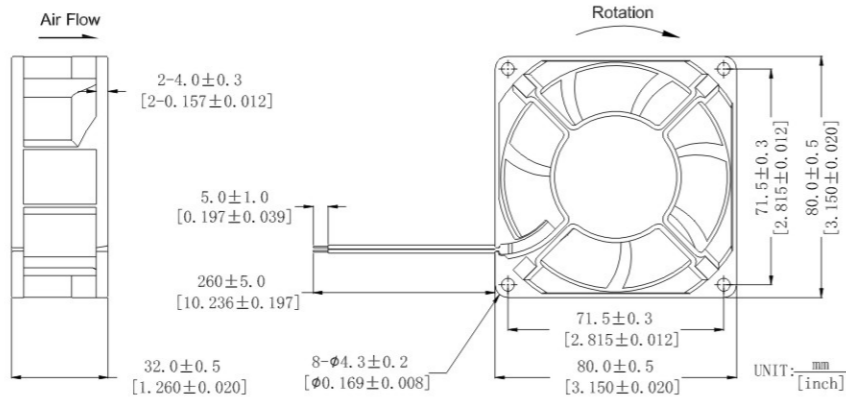

### 可选的功能参照列表 (Available Functions)

#### 1. 马达保护 (Motor protection)

RP	SS	AS	CL
<input type="checkbox"/>	<input type="checkbox"/>	<input type="checkbox"/>	<input type="checkbox"/>

#### 2. 信号输出 (Signal output)

FG	RD	RD	LD
<input type="checkbox"/>	<input type="checkbox"/>	<input type="checkbox"/>	<input type="checkbox"/>

#### 3. 调速方式 (Speed control mode)

PWM	TP	VC	RC	CS
<input type="checkbox"/>	<input type="checkbox"/>	<input type="checkbox"/>	<input type="checkbox"/>	<input type="checkbox"/>

Part Number	Voltage(V)	Fre.(HZ)	Power(W)	Speed(RPM)	Air flow(Q)	Pressure(P)	Noise(dBA)
产品编号	电压范围	频率范围	功率	转速	(CFM) 风量	(Mmaq)风压 (In H <sub>2</sub> O)	噪音
RT8032x11D	110(80~120)	45~65	3.6	2400	29.89	3.26	22.5
RT8032x11L		45~65	4.0	3000	37.07	5.01	25.0
RT8032x11M		45~65	4.5	3600	44.24	7.14	36.5
RT8032x22D	220(120~240)	45~65	3.6	2400	29.89	3.26	22.5
RT8032x22L		45~65	4.0	3000	37.07	5.01	25.0
RT8032x22M		45~65	4.5	3600	44.24	7.14	36.5

- ★ 如果您需要的转速或电压或功能不在这份清单上, 请与我们联系。  
If you want another rpm or voltage or functions which one is not in the list, please contact with our sales.
- ★ 提示1: 功能的具体信息参照产品目录前页篇章。  
Notes1: The catalog have detail information in the front page for the functions.
- ★ 提示2: 产品详细信息请参照承认书。  
Notes2: Product have a detail in the approval sheet.
- ★ 提示3: 产品规格变更不另行通知。  
Notes3: Specifications are subject to change without notice.
- ★ 提示4: 该款机型可制作相同转速的, 可在AC110V和AC220V双电压下使用。  
Note4: This model can be made in the same speed and used in AC110V, AC220V both.

# EC (AC TO DC) FAN

## 80\*80\*38mm RT8038 Series CE



外框材质:环保防火PBT  
Frame:Thermoplastic PBT UL94-V0  
扇叶材质:环保防火PBT  
Impeller:Thermoplastic PBT UL94-V0  
轴承结构:双滚珠或长寿命含油结构  
Bearing system:2Ball or Long life sleeve  
单体风扇重量:153g  
Unit Weight:153g

DIMENSIONS DRAWING

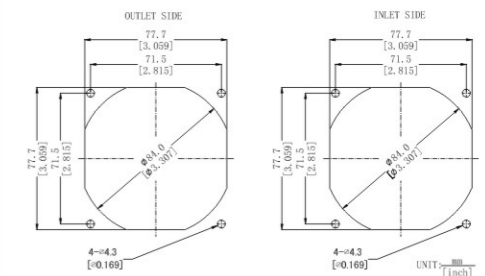
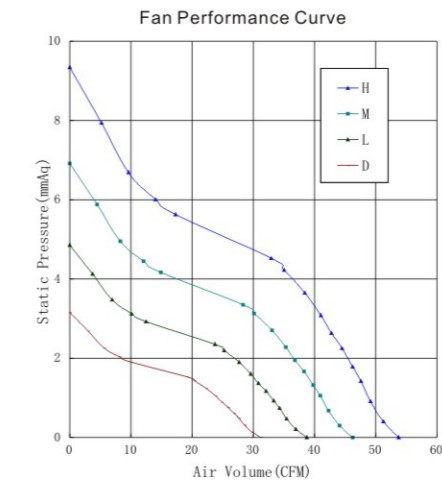
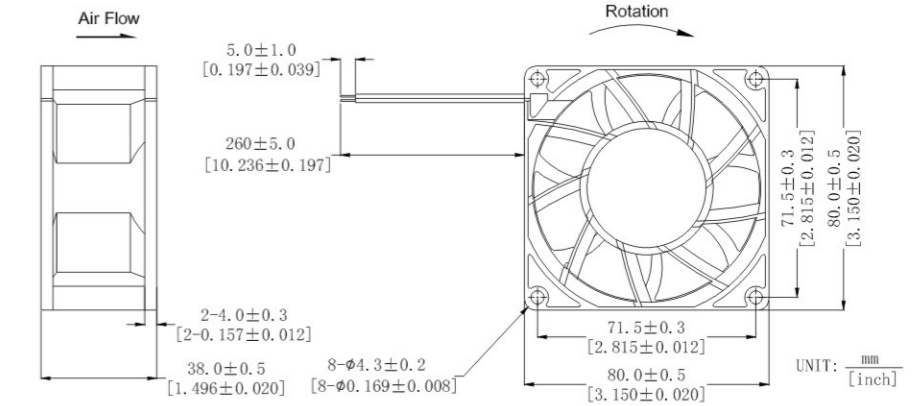

### 可选的功能参照列表 (Available Functions)

#### 1. 马达保护 (Motor protection)

RP	SS	AS	CL
<input type="checkbox"/>	<input type="checkbox"/>	<input type="checkbox"/>	<input type="checkbox"/>

#### 2. 信号输出 (Signal output)

FG	RD	RD	LD
<input type="checkbox"/>	<input type="checkbox"/>	<input type="checkbox"/>	<input type="checkbox"/>

#### 3. 调速方式 (Speed control mode)

PWM	TP	VC	RC	CS
<input type="checkbox"/>	<input type="checkbox"/>	<input type="checkbox"/>	<input type="checkbox"/>	<input type="checkbox"/>

Part Number	Voltage(V)	Fre.(HZ)	Power(W)	Speed(RPM)	Air flow(Q)	Pressure(P)	Noise(dBA)
产品编号	电压范围	频率范围	功率	转速	(CFM) 风量	(Mmaq)风压 (In H <sub>2</sub> O)	噪音
RT8038x11D	110(80~120)	45~65	3.0	2400	31.24	3.16	22.5
RT8038x11L		45~65	3.6	3000	38.73	4.85	25.0
RT8038x11M		45~65	4.0	3600	46.23	6.91	36.5
RT8038x11H		45~65	4.5	4200	53.73	9.34	39.5
RT8038x22D	220(120~240)	45~65	3.0	2400	31.24	3.16	22.5
RT8038x22L		45~65	3.6	3000	38.73	4.85	25.0
RT8038x22M		45~65	4.0	3600	46.23	6.91	36.5
RT8038x22H		45~65	4.5	4200	53.73	9.34	39.5

- ★ 如果您需要的转速或电压或功能不在这份清单上, 请与我们联系。  
If you want another rpm or voltage or functions which one is not in the list, please contact with our sales.
- ★ 提示1: 功能的具体信息参照产品目录前页篇章。  
Notes1: The catalog have detail information in the front page for the functions.
- ★ 提示2: 产品详细信息请参照承认书。  
Notes2: Product have a detail in the approval sheet.
- ★ 提示3: 产品规格变更不另行通知。  
Notes3: Specifications are subject to change without notice.
- ★ 提示4: 该款机型可制作相同转速的, 可在AC110V和AC220V双电压下使用。  
Note4: This model can be made in the same speed and used in AC110V, AC220V both.

# EC (AC TO DC) FAN

## 92\*92\*25mm RT9225 Series CE



外框材质:环保防火PBT  
Frame:Thermoplastic PBT UL94-V0  
扇叶材质:环保防火PBT  
Impeller:Thermoplastic PBT UL94-V0  
轴承结构:双滚珠或长寿命含油结构  
Bearing system:2Ball or Long life sleeve  
单体风扇重量:78g  
Unit Weight:78g

### 可选的功能参照列表 (Available Functions)

#### 1.马达保护(Motor protection)

RP	SS	AS	CL
<input type="checkbox"/>	<input type="checkbox"/>	<input type="checkbox"/>	<input type="checkbox"/>

#### 2.信号输出(Signal output)

FG	RD	RD	LD
<input type="checkbox"/>	<input type="checkbox"/>	<input type="checkbox"/>	<input type="checkbox"/>

#### 3.调速方式(Speed control mode)

PWM	TP	VC	RC	CS
<input type="checkbox"/>	<input type="checkbox"/>	<input type="checkbox"/>	<input type="checkbox"/>	<input type="checkbox"/>

DIMENSIONS DRAWING

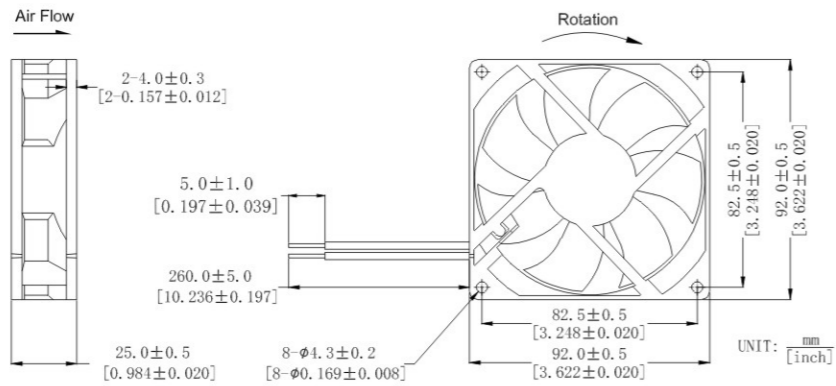

Fan Performance Curve

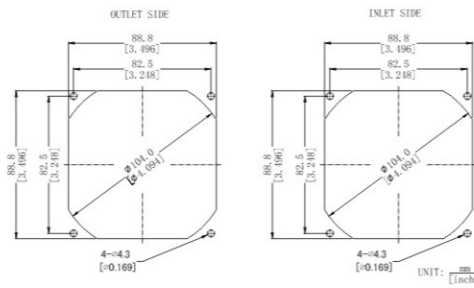
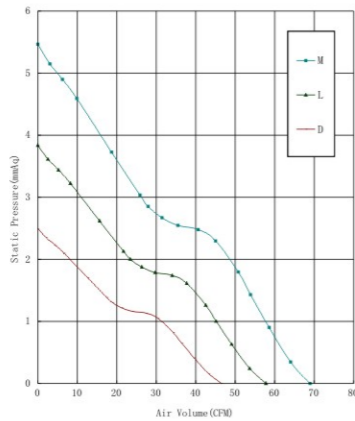

# EC (AC TO DC) FAN

## 92\*92\*32mm RT9232 Series CE



外框材质:环保防火PBT  
Frame:Thermoplastic PBT UL94-V0  
扇叶材质:环保防火PBT  
Impeller:Thermoplastic PBT UL94-V0  
轴承结构:双滚珠或长寿命含油结构  
Bearing system:2Ball or Long life sleeve  
单体风扇重量:150g  
Unit Weight:150g

### 可选的功能参照列表 (Available Functions)

#### 1.马达保护(Motor protection)

RP	SS	AS	CL
<input type="checkbox"/>	<input type="checkbox"/>	<input type="checkbox"/>	<input type="checkbox"/>

#### 2.信号输出(Signal output)

FG	RD	RD	LD
<input type="checkbox"/>	<input type="checkbox"/>	<input type="checkbox"/>	<input type="checkbox"/>

#### 3.调速方式(Speed control mode)

PWM	TP	VC	RC	CS
<input type="checkbox"/>	<input type="checkbox"/>	<input type="checkbox"/>	<input type="checkbox"/>	<input type="checkbox"/>

DIMENSIONS DRAWING

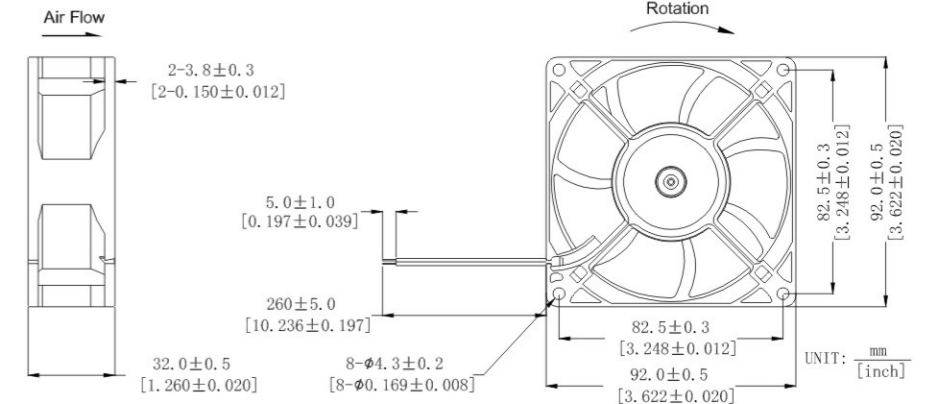

Fan Performance Curve

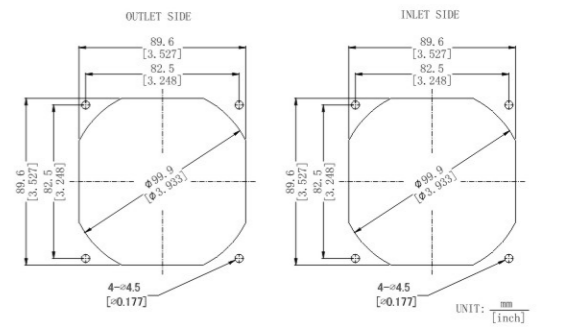
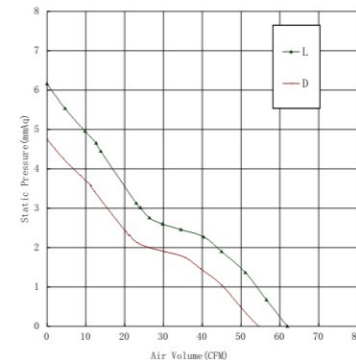

Part Number	Voltage(V)	Fre.(HZ)	Power(W)	Speed(RPM)	Air flow(Q)	Pressure(P)	Noise(dBA)
产品编号	电压范围	频率范围	功率	转速	(CFM) 风量	(Mmaq)风压	(In H <sub>2</sub> O) 噪音
RT9225x11D	110(80~120)	45~65	3.2	2400	46.60	2.50	32.7
RT9225x11L		45~65	4.0	3000	57.79	3.84	37.4
RT9225x11M		45~65	4.4	3600	68.97	5.45	42.8
RT9225x22D	220(120~240)	45~65	3.2	2400	46.60	2.50	32.7
RT9225x22L		45~65	4.0	3000	57.79	3.84	37.4
RT9225x22M		45~65	4.4	3600	68.97	5.45	42.8

Part Number	Voltage(V)	Fre.(HZ)	Power(W)	Speed(RPM)	Air flow(Q)	Pressure(P)	Noise(dBA)
产品编号	电压范围	频率范围	功率	转速	(CFM) 风量	(Mmaq)风压	(In H <sub>2</sub> O) 噪音
RT9232x11D	110(80~120)	45~65	3.6	2800	54.41	4.76	39.6
RT9232x11L		45~65	4.2	3200	61.92	6.16	43.2
RT9232x22D	220(120~240)	45~65	3.6	2800	54.41	4.76	39.6
RT9232x22L		45~65	4.2	3200	61.92	6.16	43.2

★ 如果您需要的转速或电压或功能不在这份清单上, 请与我们联系。  
If you want another rpm or voltage or functions which one is not in the list, please contact with our sales.

★ 提示1:功能的具体信息参照产品目录前页篇章。  
Notes1:The catalog have detail information in the front page for the functions.

★ 提示2:产品详细信息请参照承认书。  
Notes2:Product have a detail in the approval sheet.

★ 提示3:产品规格变更不另行通知。  
Notes3:Specifications are subject to change without notice.

★ 提示4:该款机型可制作相同转速的, 可在AC110V和AC220V双电压下使用。  
Note4:This model can be made in the same speed and used in AC110V, AC220V both.

★ 如果您需要的转速或电压或功能不在这份清单上, 请与我们联系。  
If you want another rpm or voltage or functions which one is not in the list, please contact with our sales.

★ 提示1:功能的具体信息参照产品目录前页篇章。  
Notes1:The catalog have detail information in the front page for the functions.

★ 提示2:产品详细信息请参照承认书。  
Notes2:Product have a detail in the approval sheet.

★ 提示3:产品规格变更不另行通知。  
Notes3:Specifications are subject to change without notice.

★ 提示4:该款机型可制作相同转速的, 可在AC110V和AC220V双电压下使用。  
Note4:This model can be made in the same speed and used in AC110V, AC220V both.

## 92\*92\*38mm

### RT9238 Series

# CE



外框材质:环保防火PBT  
 Frame:Thermoplastic PBT UL94-V0  
 扇叶材质:环保防火PBT  
 Imperller:Thermoplastic PBT UL94-V0  
 轴承结构:双滚珠或长寿命含油结构  
 Bearing system:2Ball or Long life sleeve  
 单体风扇重量:198g  
 Unit Weight:198g

#### 可选的功能参照列表 (Available Functions)

1.马达保护(Motor protection)

RP	SS	AS	CL
<input type="checkbox"/>	<input type="checkbox"/>	<input type="checkbox"/>	<input type="checkbox"/>

2.信号输出(Signal output)

FG	RD	RD	LD
<input type="checkbox"/>	<input type="checkbox"/>	<input type="checkbox"/>	<input type="checkbox"/>

3.调速方式(Speed control mode)

PWM	TP	VC	RC	CS
<input type="checkbox"/>	<input type="checkbox"/>	<input type="checkbox"/>	<input type="checkbox"/>	<input type="checkbox"/>

DIMENSIONS DRAWING

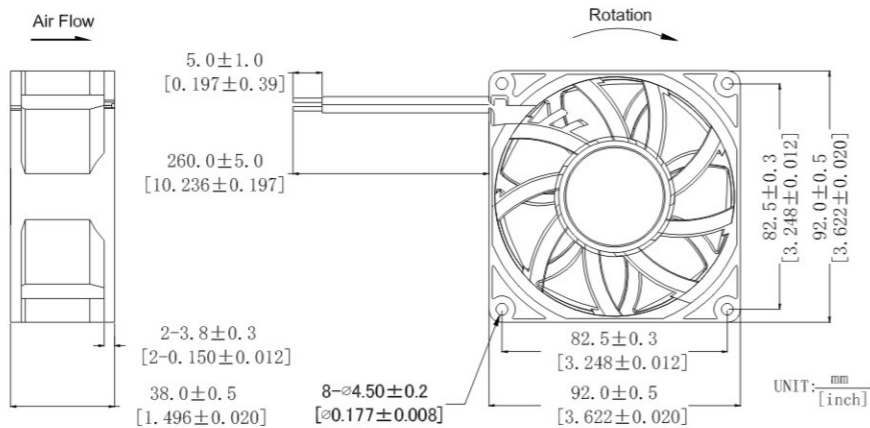

Fan Performance Curve

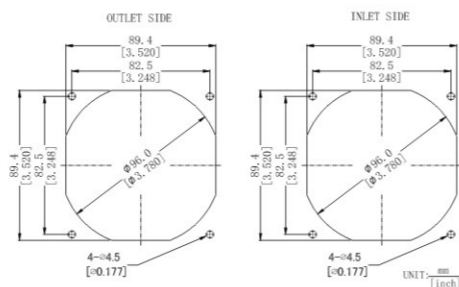
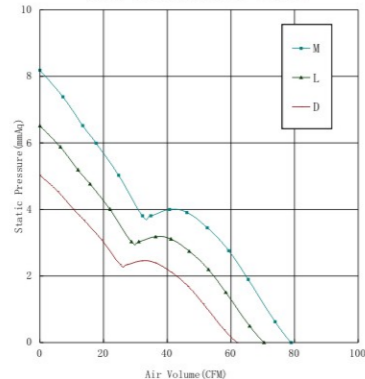

Part Number	Voltage(V)	Fre.(HZ)	Power(W)	Speed(RPM)	Air flow(Q)	Pressure(P)	Noise(dBA)
产品编号	电压范围	频率范围	功率	转速	(CFM) 风量	(Mmaq)风压 (In H <sub>2</sub> O)	噪音
RT9238x11D	110(80~120)	45~65	3.6	2800	61.88	1.75	35.9
RT9238x11L		45~65	4.0	3200	70.41	1.99	39.4
RT9238x11M		45~65	4.6	3600	78.95	2.23	42.5
RT9238x22D	220(120~240)	45~65	3.6	2800	61.88	1.75	35.9
RT9238x22L		45~65	4.0	3200	70.41	1.99	39.4
RT9238x22M		45~65	4.6	3600	78.95	2.23	42.5

★ 如果您需要的转速或电压或功能不在这份清单上, 请与我们联系。  
 If you want another rpm or voltage or functions which one is not in the list, please contact with our sales.

★ 提示1:功能的具体信息参照产品目录前页篇章。  
 Notes1:The catalog have detail information in the front page for the functions.

★ 提示2:产品详细信息请参照承认书。  
 Notes2:Product have a detail in the approval sheet.

★ 提示3:产品规格变更不另行通知。  
 Notes3:Specifications are subject to change without notice.

★ 提示4:该款机型可制作相同转速的, 可在AC110V和AC220V双电压下使用。  
 Note4:This model can be made in the same speed and used in AC110V, AC220V both.

## 120\*120\*25mm

### RT12025 Series

# CE



外框材质:环保防火PBT  
 Frame:Thermoplastic PBT UL94-V0  
 扇叶材质:环保防火PBT  
 Imperller:Thermoplastic PBT UL94-V0  
 轴承结构:双滚珠或长寿命含油结构  
 Bearing system:2Ball or Long life sleeve  
 单体风扇重量:125g  
 Unit Weight:125g

#### 可选的功能参照列表 (Available Functions)

1.马达保护(Motor protection)

RP	SS	AS	CL
<input type="checkbox"/>	<input type="checkbox"/>	<input type="checkbox"/>	<input type="checkbox"/>

2.信号输出(Signal output)

FG	RD	RD	LD
<input type="checkbox"/>	<input type="checkbox"/>	<input type="checkbox"/>	<input type="checkbox"/>

3.调速方式(Speed control mode)

PWM	TP	VC	RC	CS
<input type="checkbox"/>	<input type="checkbox"/>	<input type="checkbox"/>	<input type="checkbox"/>	<input type="checkbox"/>

DIMENSIONS DRAWING

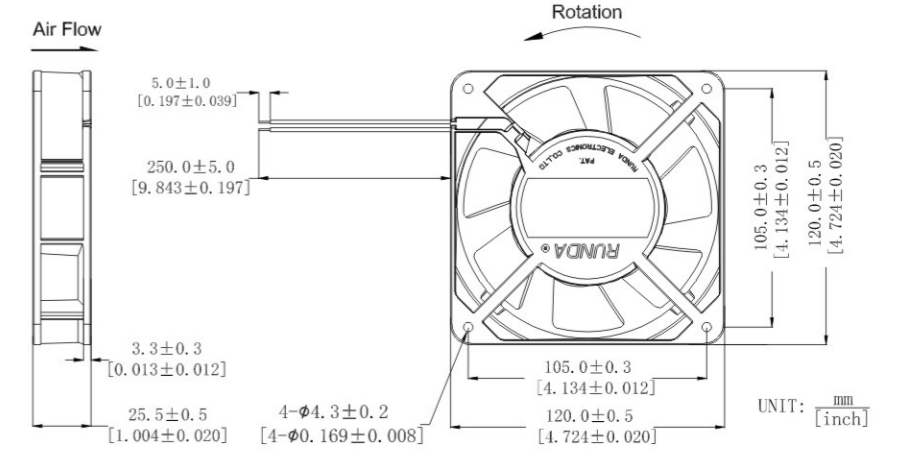

Fan Performance Curve

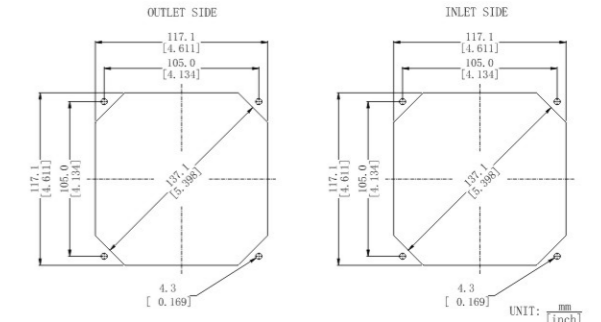
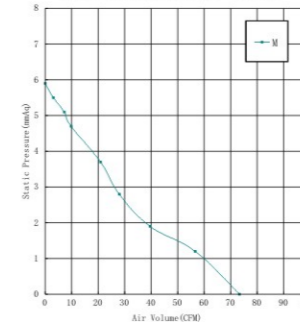

Part Number	Voltage(V)	Fre.(HZ)	Power(W)	Speed(RPM)	Air flow(Q)	Pressure(P)	Noise(dBA)
产品编号	电压范围	频率范围	功率	转速	(CFM) 风量	(Mmaq)风压 (In H <sub>2</sub> O)	噪音
RT1225B11M	110(80~120)	45~65	4.2	2800	73.30	2.07	43.2
RT1225B22M	220(120~240)	45~65	4.2	2800	73.30	2.07	43.2

★ 如果您需要的转速或电压或功能不在这份清单上, 请与我们联系。  
 If you want another rpm or voltage or functions which one is not in the list, please contact with our sales.

★ 提示1:功能的具体信息参照产品目录前页篇章。  
 Notes1:The catalog have detail information in the front page for the functions.

★ 提示2:产品详细信息请参照承认书。  
 Notes2:Product have a detail in the approval sheet.

★ 提示3:产品规格变更不另行通知。  
 Notes3:Specifications are subject to change without notice.

★ 提示4:该款机型可制作相同转速的, 可在AC110V和AC220V双电压下使用。  
 Note4:This model can be made in the same speed and used in AC110V, AC220V both.

**120\*120\*38mm**  
**RT1238 Series**  
CE

节能的高性价比 Energy-save and Cost Effective

DIMENSIONS DRAWING

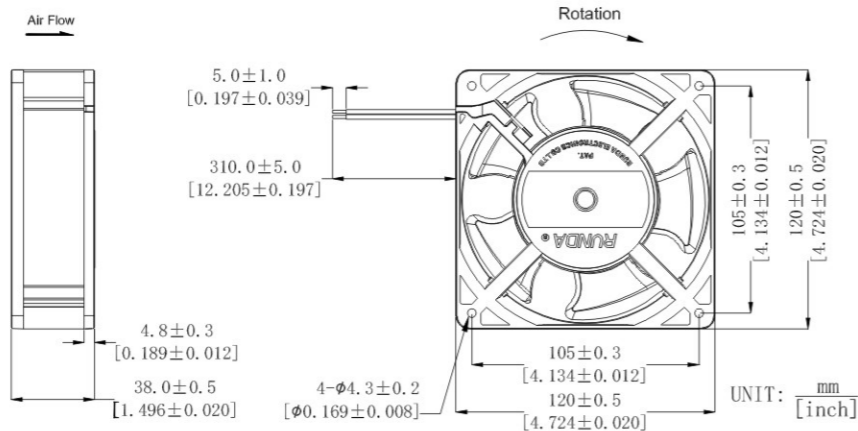

外框材质:环保防火PBT  
Frame:Thermoplastic PBT UL94-V0  
扇叶材质:环保防火PBT  
Impeller:Thermoplastic PBT UL94-V0  
轴承结构:双滚珠或长寿命含油结构  
Bearing system:2Ball or Long life sleeve  
单体风扇重量:250g  
Unit Weight:250g

可选的功能参照列表  
(Available Functions)

1.马达保护(Motor protection)

RP	SS	AS	CL
<input type="checkbox"/>	<input type="checkbox"/>	<input type="checkbox"/>	<input type="checkbox"/>

2.信号输出(Signal output)

FG	RD	RD	LD
<input type="checkbox"/>	<input type="checkbox"/>	<input type="checkbox"/>	<input type="checkbox"/>

3.调速方式(Speed control mode)

PWM	TP	VC	RC	CS
<input type="checkbox"/>	<input type="checkbox"/>	<input type="checkbox"/>	<input type="checkbox"/>	<input type="checkbox"/>

Fan Performance Curve

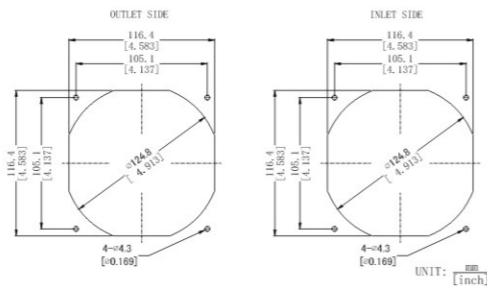
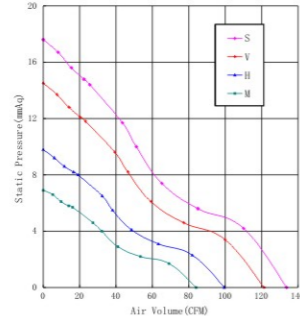

Part Number	Voltage(V)	Fre.(HZ)	Power(W)	Speed(RPM)	Air flow(Q)	Pressure(P)	Noise(dBA)
产品编号	电压范围	频率范围	功率	转速	(CFM) 风量	m <sup>3</sup> /min (Mmaq)风压 (In H <sub>2</sub> O)	噪音
RT1238x11M	110(80~120)	45~65	5.0	2600	84.00	2.38	41.7
RT1238x11H		45~65	6.0	3200	99.50	2.81	47.8
RT1238x11VH		45~65	8.0	3800	121.30	3.43	51.5
RT1238x11SH		45~65	13.0	4200	133.70	3.78	55.1
RT1238x22M	220(120~240)	45~65	5.0	2600	84.00	2.38	41.7
RT1238x22H		45~65	6.0	3200	99.50	2.81	47.8
RT1238x22VH		45~65	8.0	3800	121.30	3.43	51.5
RT1238x22SH		45~65	13.0	4200	133.70	3.78	55.1

- ★ 如果您需要的转速或电压或功能不在这份清单上, 请与我们联系。  
If you want another rpm or voltage or functions which one is not in the list, please contact with our sales.
- ★ 提示1:功能的具体信息参照产品目录前页篇章。  
Notes1:The catalog have detail information in the front page for the functions.
- ★ 提示2:产品详细信息请参照承认书。  
Notes2:Product have a detail in the approval sheet.
- ★ 提示3:产品规格变更不另行通知。  
Notes3:Specifications are subject to change without notice.
- ★ 提示4:该款机型可制作相同转速的, 可在AC110V和AC220V双电压下使用。  
Note4:This model can be made in the same speed and used in AC110V, AC220V both.

**160\*160\*50mm**  
**RT16050 Series**  
CE

DIMENSIONS DRAWING

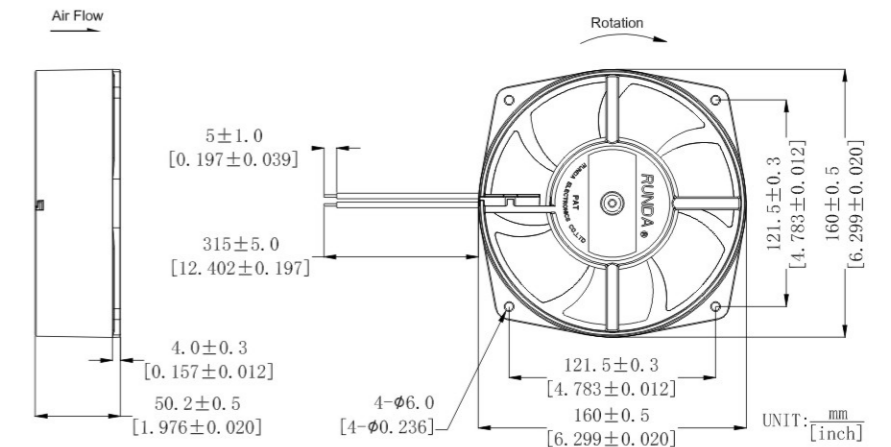

外框材质:环保防火PBT  
Frame:Thermoplastic PBT UL94-V0  
扇叶材质:环保防火PBT  
Impeller:Thermoplastic PBT UL94-V0  
轴承结构:双滚珠  
Bearing system:2Ball  
单体风扇重量:470g  
Unit Weight:470g

可选的功能参照列表  
(Available Functions)

1.马达保护(Motor protection)

RP	SS	AS	CL
<input type="checkbox"/>	<input type="checkbox"/>	<input type="checkbox"/>	<input type="checkbox"/>

2.信号输出(Signal output)

FG	RD	RD	LD
<input type="checkbox"/>	<input type="checkbox"/>	<input type="checkbox"/>	<input type="checkbox"/>

3.调速方式(Speed control mode)

PWM	TP	VC	RC	CS
<input type="checkbox"/>	<input type="checkbox"/>	<input type="checkbox"/>	<input type="checkbox"/>	<input type="checkbox"/>

Fan Performance Curve

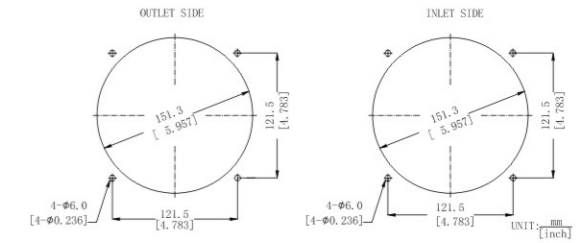
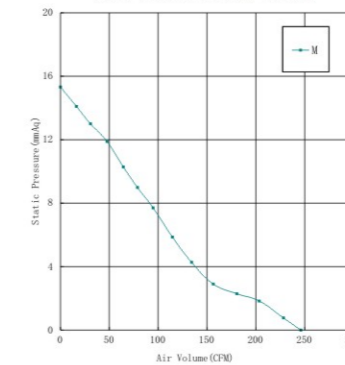

Part Number	Voltage(V)	Fre.(HZ)	Power(W)	Speed(RPM)	Air flow(Q)	Pressure(P)	Noise(dBA)
产品编号	电压范围	频率范围	功率	转速	(CFM) 风量	m <sup>3</sup> /min (Mmaq)风压 (In H <sub>2</sub> O)	噪音
RT16050B11M	110(80~130)	45~65	16	2800	246.20	6.71	52.5
RT16050B22M	220(120~250)	45~65	16	2800	246.20	6.71	52.5
RT16050B38M	380(260~450)	45~65	16	2800	246.20	6.71	52.5

- ★ 如果您需要的转速或电压或功能不在这份清单上, 请与我们联系。  
If you want another rpm or voltage or functions which one is not in the list, please contact with our sales.
- ★ 提示1:功能的具体信息参照产品目录前页篇章。  
Notes1:The catalog have detail information in the front page for the functions.
- ★ 提示2:产品详细信息请参照承认书。  
Notes2:Product have a detail in the approval sheet.
- ★ 提示3:产品规格变更不另行通知。  
Notes3:Specifications are subject to change without notice.
- ★ 提示4:该款机型可制作相同转速的, 可在AC110V和AC220V双电压下使用。  
Note4:This model can be made in the same speed and used in AC110V, AC220V both.

# EC (AC TO DC) FAN



**172\*150\*51mm**  
**RT17251 Series**  
**CE**

DIMENSIONS DRAWING



全圆框也可生产 Round frame is available

外框材质:铝合金  
 Frame:Aluminum  
 扇叶材质:环保防火PBT  
 Impeller:Thermoplastic PBT UL94-V0  
 轴承结构:双滚珠  
 Bearing system:2Ball  
 单体风扇重量:720g  
 Unit Weight:720g

**可选的功能参照列表**  
 (Available Functions)

1.马达保护(Motor protection)

RP	SS	AS	CL
<input type="checkbox"/>	<input type="checkbox"/>	<input type="checkbox"/>	<input type="checkbox"/>

2.信号输出(Signal output)

FG	RD	RD	LD
<input type="checkbox"/>	<input type="checkbox"/>	<input type="checkbox"/>	<input type="checkbox"/>

3.调速方式(Speed control mode)

PWM	TP	VC	RC	CS
<input type="checkbox"/>	<input type="checkbox"/>	<input type="checkbox"/>	<input type="checkbox"/>	<input type="checkbox"/>

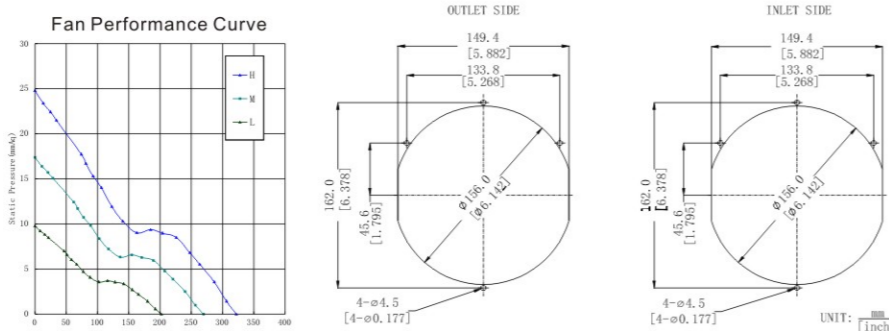
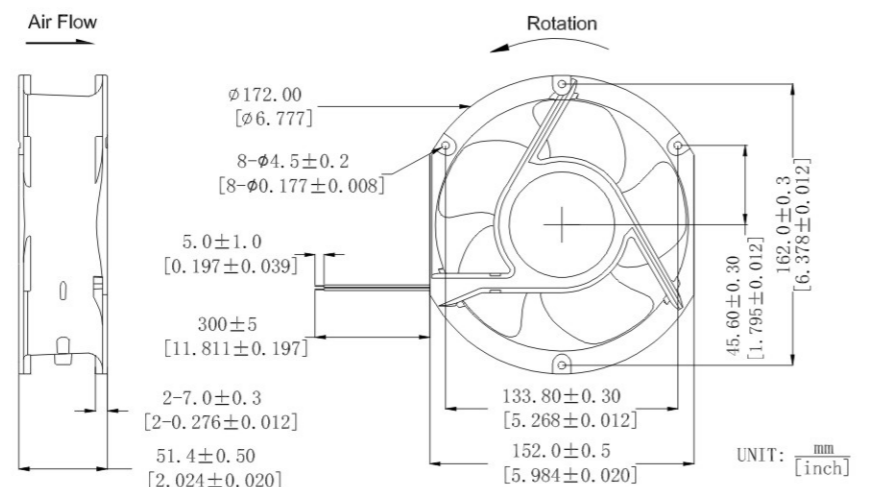

Part Number	Voltage(V)	Fre.(HZ)	Power(W)	Speed(RPM)	Air flow(Q)	Pressure(P)	Noise(dBA)		
产品编号	电压范围	频率范围	功率	转速	(CFM) 风量	(Mmaq)风压	(In H <sub>2</sub> O) 噪音		
RT17251x11M	110(90~130)	45~65	20	3500	269.65	7.63	17.38	0.68	56.9
RT17251x11H		45~65	32	4200	322.10	9.11	24.79	0.98	61.7
RT17251x22M	220(150~230)	45~65	20	3500	269.65	7.63	17.38	0.68	56.9
RT17251x22H		45~65	32	4200	322.10	9.11	24.79	0.98	61.7

- ★ 如果您需要的转速或电压或功能不在这份清单上, 请与我们联系。  
 If you want another rpm or voltage or functions which one is not in the list, please contact with our sales.
- ★ 提示1:功能的具体信息参照产品目录前页篇章。  
 Notes1:The catalog have detail information in the front page for the functions.
- ★ 提示2:产品详细信息请参照承认书。  
 Notes2:Product have a detail in the approval sheet.
- ★ 提示3:产品规格变更不另行通知。  
 Notes3:Specifications are subject to change without notice.
- ★ 提示4:该款机型可制作相同转速的, 可在AC110V和AC220V双电压下使用。  
 Note4:This model can be made in the same speed and used in AC110V, AC220V both.

# EC (AC TO DC) FAN



**200\*200\*70mm**  
**RT20070Series**  
**CE**

DIMENSIONS DRAWING



外框材质:环保防火PBT  
 Frame:Thermoplastic PBT UL94-V0  
 扇叶材质:环保防火PBT  
 Impeller:Thermoplastic PBT UL94-V0  
 轴承结构:双滚珠  
 Bearing system:2Ball  
 单体风扇重量:750g  
 Unit Weight:750g

**可选的功能参照列表**  
 (Available Functions)

1.马达保护(Motor protection)

RP	SS	AS	CL
<input type="checkbox"/>	<input type="checkbox"/>	<input type="checkbox"/>	<input type="checkbox"/>

2.信号输出(Signal output)

FG	RD	RD	LD
<input type="checkbox"/>	<input type="checkbox"/>	<input type="checkbox"/>	<input type="checkbox"/>

3.调速方式(Speed control mode)

PWM	TP	VC	RC	CS
<input type="checkbox"/>	<input type="checkbox"/>	<input type="checkbox"/>	<input type="checkbox"/>	<input type="checkbox"/>

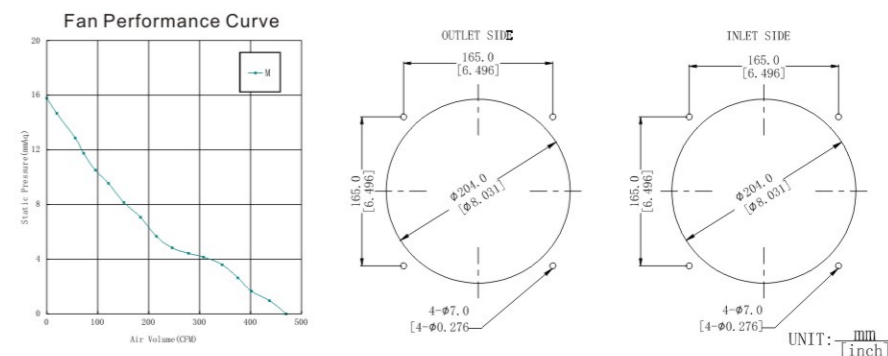
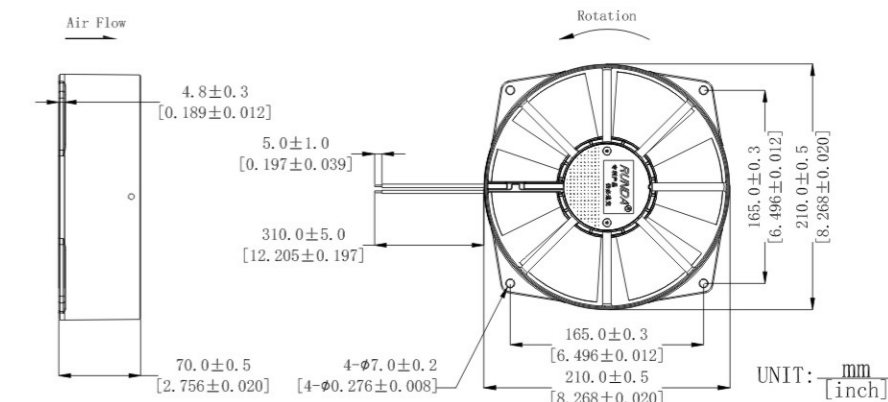

Part Number	Voltage(V)	Fre.(HZ)	Power(W)	Speed(RPM)	Air flow(Q)	Pressure(P)	Noise(dBA)		
产品编号	电压范围	频率范围	功率	转速	(CFM) 风量	(Mmaq)风压	(In H <sub>2</sub> O) 噪音		
RT20070B11M	110(80~120)	45~65	28	2600	452.47	12.79	14.63	0.58	62.8
RT20070B22M	220(120~240)	45~65	28	2600	452.47	12.79	14.63	0.58	62.8

- ★ 如果您需要的转速或电压或功能不在这份清单上, 请与我们联系。  
 If you want another rpm or voltage or functions which one is not in the list, please contact with our sales.
- ★ 提示1:功能的具体信息参照产品目录前页篇章。  
 Notes1:The catalog have detail information in the front page for the functions.
- ★ 提示2:产品详细信息请参照承认书。  
 Notes2:Product have a detail in the approval sheet.
- ★ 提示3:产品规格变更不另行通知。  
 Notes3:Specifications are subject to change without notice.
- ★ 提示4:该款机型可制作相同转速的, 可在AC110V和AC220V双电压下使用。  
 Note4:This model can be made in the same speed and used in AC110V, AC220V both.

## 254\*89mm

### RT25489 Series

CE

## 80\*80\*25mm

### AC8025 Series

UL CE TUV SUD



外框材质:铝合金  
Frame:Aluminum  
扇叶材质:环保防火PBT  
Impeller:Thermoplastic PBT UL94-V0  
轴承结构:双滚珠  
Bearing system:2Ball  
单体风扇重量:2410g  
Unit Weight:2410g

DIMENSIONS DRAWING

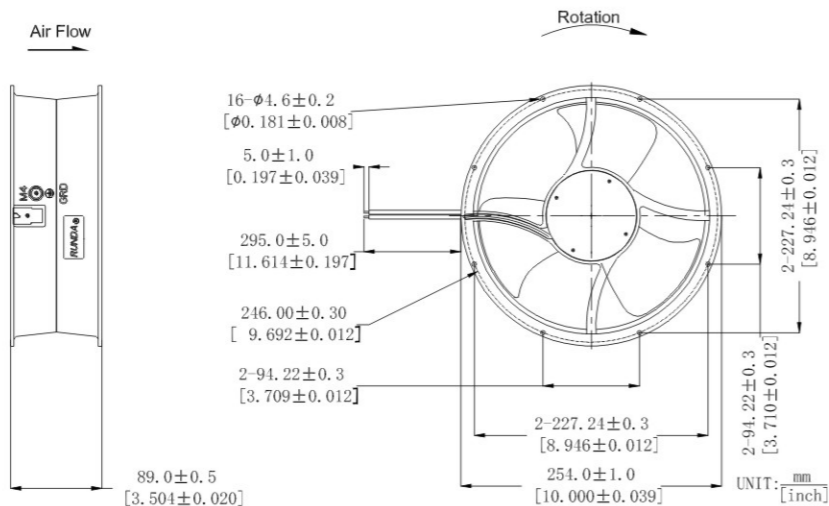

#### 可选的功能参照列表 (Available Functions)

##### 1.马达保护(Motor protection)

RP	SS	AS	CL
<input type="checkbox"/>	<input type="checkbox"/>	<input type="checkbox"/>	<input type="checkbox"/>

##### 2.信号输出(Signal output)

FG	RD	RD	LD
<input type="checkbox"/>	<input type="checkbox"/>	<input type="checkbox"/>	<input type="checkbox"/>

##### 3.调速方式(Speed control mode)

PWM	TP	VC	RC	CS
<input type="checkbox"/>	<input type="checkbox"/>	<input type="checkbox"/>	<input type="checkbox"/>	<input type="checkbox"/>

Fan Performance Curve

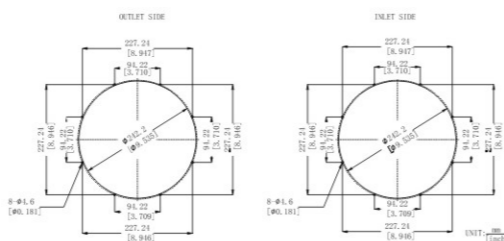
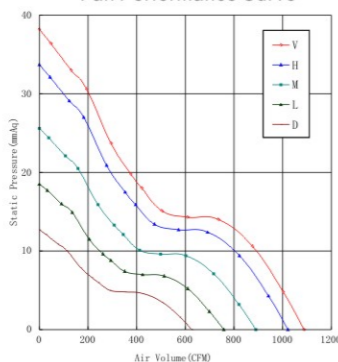

Part Number	Voltage(V)	Fre.(HZ)	Power(W)	Speed(RPM)	Air flow(Q)	Pressure(P)	Noise(dBA)
产品编号	电压范围	频率范围	功率	转速	(CFM) 风量	m <sup>3</sup> /min (Mmaq)风压 (In H <sub>2</sub> O)	噪音
RT25489x11D	110(80~130)	45~65	28	1800	626.26	17.72 12.65	0.50 57.0
RT25489x11L		45~65	39	2200	758.11	21.45 18.54	0.73 61.2
RT25489x11M		45~65	68	2600	899.96	25.46 25.55	1.01 65.8
RT25489x22D	220(150~230)	45~65	28	1800	626.26	17.72 12.65	0.50 57.0
RT25489x22L		45~65	39	2200	758.11	21.45 18.54	0.73 61.2
RT25489x22M		45~65	68	2600	899.96	25.46 25.55	1.01 65.8

★ 如果您需要的转速或电压或功能不在这份清单上, 请与我们联系。  
If you want another rpm or voltage or functions which one is not in the list, please contact with our sales.

★ 提示1:功能的具体信息参照产品目录前页篇章。  
Notes1:The catalog have detail information in the front page for the functions.

★ 提示2:产品详细信息请参照承认书。  
Notes2:Product have a detail in the approval sheet.

★ 提示3:产品规格变更不另行通知。  
Notes3:Specifications are subject to change without notice.

★ 提示4:该款机型可制作相同转速的, 可在AC110V和AC220V双电压下使用。  
Note4:This model can be made in the same speed and used in AC110V, AC220V both.



外框材质:铝合金  
Frame:Aluminum  
扇叶材质:环保防火PBT  
Impeller:Thermoplastic PBT UL94-V0  
轴承结构:双滚珠或长寿命含油结构  
Bearing system:2Ball or Long life sleeve  
单体风扇重量:230g  
Unit Weight:230g

DIMENSIONS DRAWING

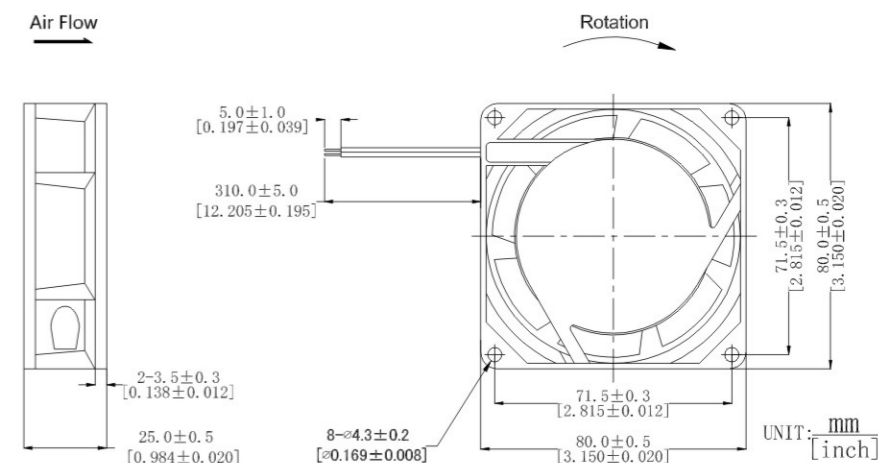

P&Q CURVE (AT RATED VOLTAGE)

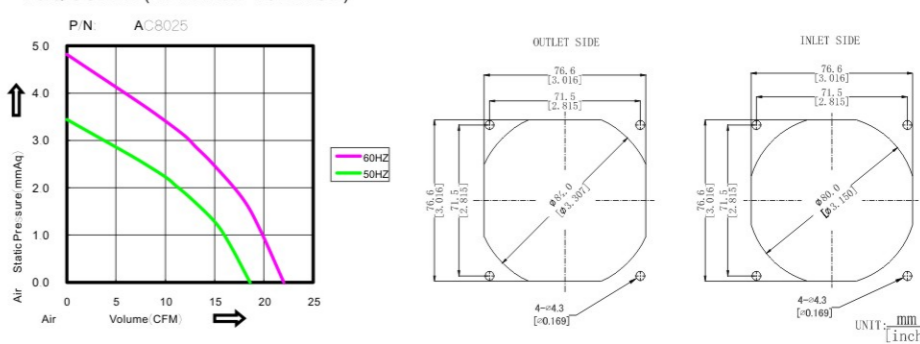

Part Number	Voltage(V)	Frequency (HZ)	Power(W)	Current (Amp)	Speed (RPM)	Air flow(Q)	Pressure(P)	Noise(dBA)
产品编号	电压	频率	功率	电流	转速	(CFM) 风量	m <sup>3</sup> /min (mmAq)风压 (In H <sub>2</sub> O)	噪音
AC8025S110H	AC 110/120	50/60	13/11	0.14/0.12	2300/2500	17/21	0.48/0.60 3.0/4.6	0.12/0.18 29/33
AC8025B110H		50/60	13/11	0.14/0.12	2400/2600	18/22	0.51/0.63 3.3/4.8	0.13/0.19 29/33
AC8025S220H	AC 220/240	50/60	13/11	0.07/0.06	2300/2500	17/21	0.48/0.60 3.0/4.6	0.12/0.18 29/33
AC8025B220H		50/60	13/11	0.07/0.06	2400/2600	18/22	0.51/0.63 3.3/4.8	0.13/0.19 29/33

★ 如果您需要的转速或电压或功能不在这份清单上, 请与我们联系。  
If you want another rpm or voltage or functions which one is not in the list, please contact with our sales.

★ 提示1:功能的具体信息参照产品目录前页篇章。  
Notes1:The catalog have detail information in the front page for the functions.

★ 提示2:产品详细信息请参照承认书。  
Notes2:Product have a detail in the approval sheet.

★ 提示3:产品规格变更不另行通知。  
Notes3:Specifications are subject to change without notice.

**80\*80\*38mm**  
AC8038 Series



DIMENSIONS DRAWING

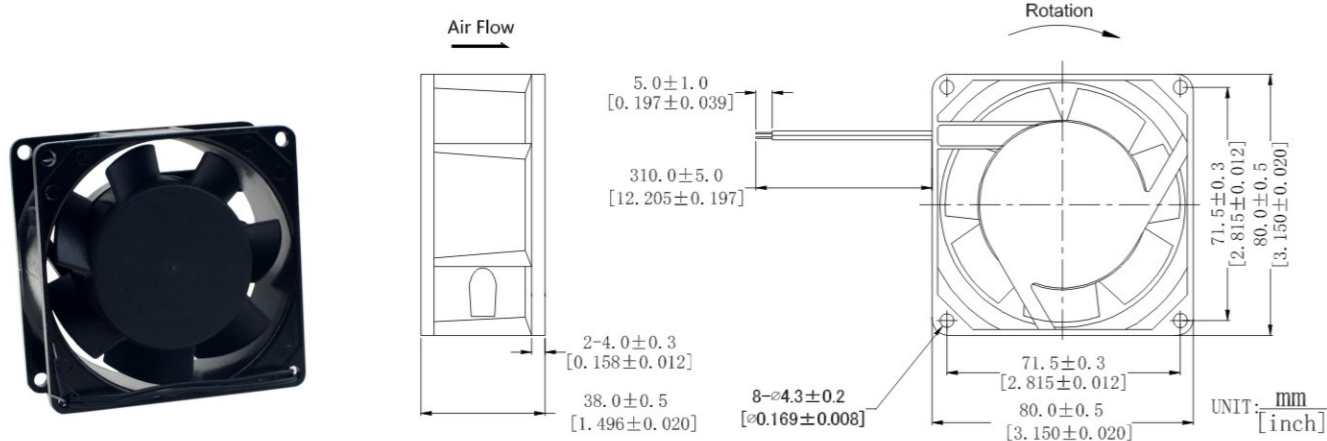

外框材质:铝合金  
Frame:Aluminum  
扇叶材质:环保防火PBT  
Impeller:Thermoplastic PBT UL94-V0  
轴承结构:双滚珠或长寿命含油结构  
Bearing system:2Ball or Long life sleeve  
单体风扇重量:270g  
Unit Weight:270g

P&Q CURVE (AT RATED VOLTAGE)

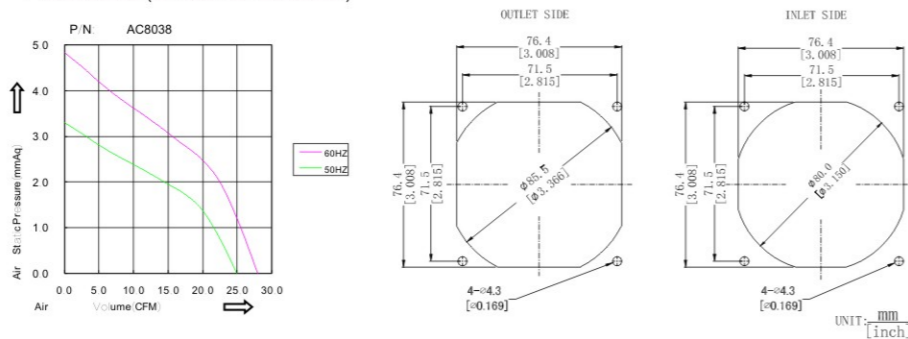

Part Number	Voltage(V)	Frequency (HZ)	Power (W)	Current (Amp)	Speed(RPM)	Air flow(Q)	Pressure(P)	Noise(dBA)
产品编号	电压	频率	功率	电流	转速	(CFM) 风量 m <sup>3</sup> /min	(mmAq)风压 (In H <sub>2</sub> O)	噪音
AC8038S110H	AC 110/120	50/60	11/8	0.14/0.12	2400/2700	25/28 0.7/0.8	3.3/4.83 0.13/0.19	30/35
AC8038B110H		50/60	11/8	0.14/0.12	2400/2700	25/28 0.7/0.8	3.3/4.83 0.13/0.19	30/35
AC8038S220H	AC 220/240	50/60	11/8	0.07/0.06	2400/2700	25/28 0.7/0.8	3.3/4.83 0.13/0.19	30/35
AC8038B220H		50/60	11/8	0.07/0.06	2400/2700	25/28 0.7/0.8	3.3/4.83 0.13/0.19	30/35

- ★ 如果您需要的转速或电压或功能不在这份清单上, 请与我们联系。  
If you want another rpm or voltage or functions which one is not in the list, please contact with our sales.
- ★ 提示1:功能的具体信息参照产品目录前页篇章。  
Notes1:The catalog have detail information in the front page for the functions.
- ★ 提示2:产品详细信息请参照承认书。  
Notes2:Product have a detail in the approval sheet.
- ★ 提示3:产品规格变更不另行通知。  
Notes3:Specifications are subject to change without notice.

**92\*92\*25mm**  
AC9225 Series



DIMENSIONS DRAWING

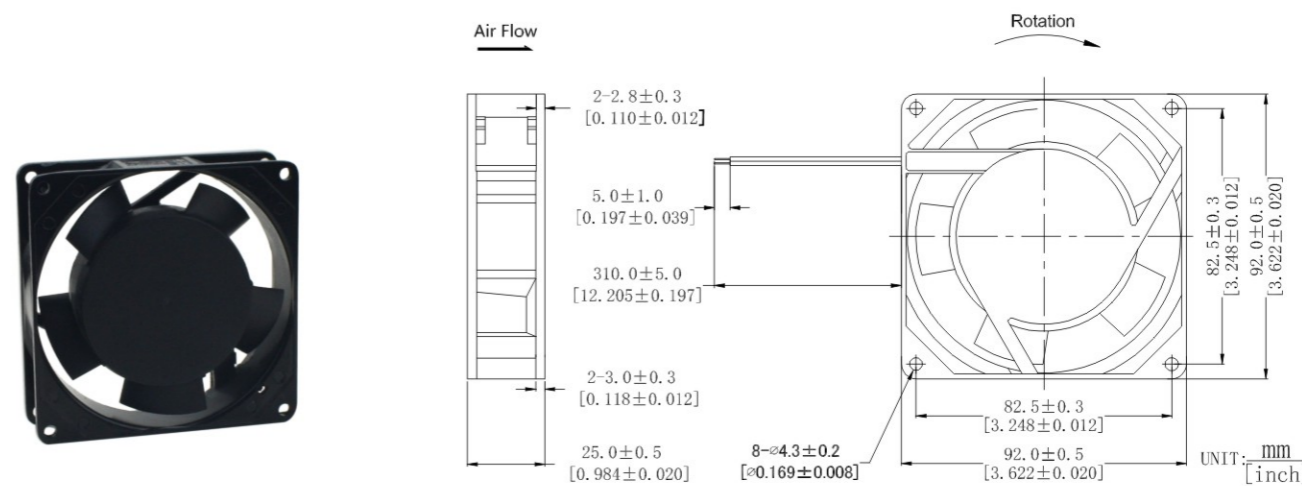

外框材质:铝合金  
Frame:Aluminum  
扇叶材质:环保防火PBT  
Impeller:Thermoplastic PBT UL94-V0  
轴承结构:双滚珠或长寿命含油结构  
Bearing system:2Ball or Long life sleeve  
单体风扇重量:250g  
Unit Weight:250g

P&Q CURVE (AT RATED VOLTAGE)

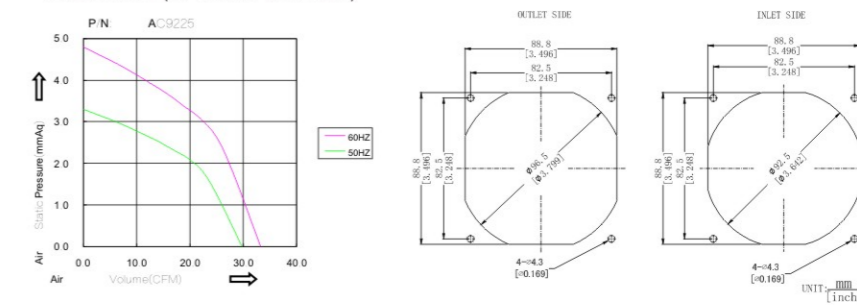

Part Number	Voltage(V)	Frequency (HZ)	Power (W)	Current (Amp)	Speed (RPM)	Air flow(Q)	Pressure(P)	Noise(dBA)
产品编号	电压	频率	功率	电流	转速	(CFM) 风量 m <sup>3</sup> /min	(mmAq)风压 (In H <sub>2</sub> O)	噪音
AC9225S110H	AC 110/120	50/60	14/12	0.14/0.12	2300/2500	28.3/31.8 0.80/0.90	3.0/4.6 0.12/0.18	35/37
AC9225B110H		50/60	14/12	0.14/0.12	2400/2600	29.7/33.2 0.84/0.94	3.3/4.8 0.13/0.19	35/37
AC9225S220H	AC 220/240	50/60	14/12	0.07/0.06	2300/2500	28.3/31.8 0.80/0.90	3.0/4.6 0.12/0.18	35/37
AC9225B220H		50/60	14/12	0.07/0.06	2400/2600	29.7/33.2 0.84/0.94	3.3/4.8 0.13/0.19	35/37

- ★ 如果您需要的转速或电压或功能不在这份清单上, 请与我们联系。  
If you want another rpm or voltage or functions which one is not in the list, please contact with our sales.
- ★ 提示1:功能的具体信息参照产品目录前页篇章。  
Notes1:The catalog have detail information in the front page for the functions.
- ★ 提示2:产品详细信息请参照承认书。  
Notes2:Product have a detail in the approval sheet.
- ★ 提示3:产品规格变更不另行通知。  
Notes3:Specifications are subject to change without notice.

# STANDARD AC AXIAL FAN



## 110\*110\*25mm

### AC11025 Series



DIMENSIONS DRAWING

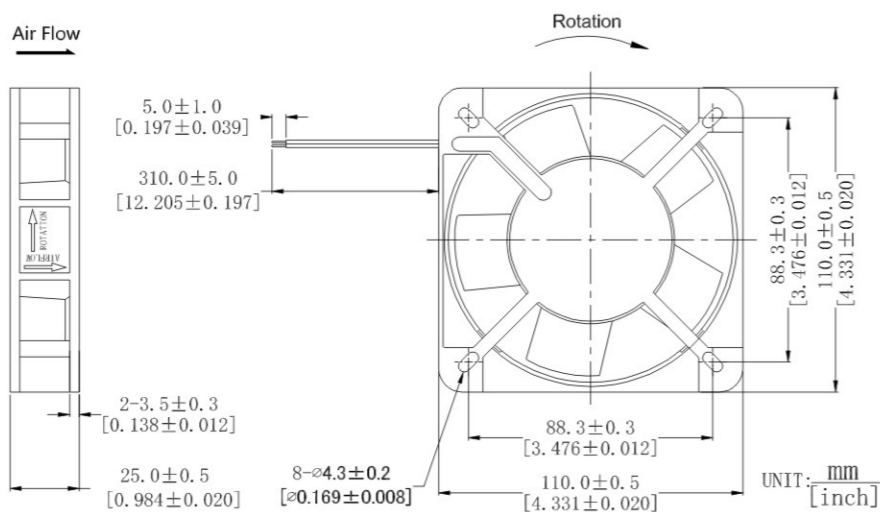

外框材质:铝合金  
Frame:Aluminum  
扇叶材质:环保防火PBT  
Impeller:Thermoplastic PBT UL94-V0  
轴承结构:双滚珠或长寿命含油结构  
Bearing system:2Ball or Long life sleeve  
单体风扇重量:270g  
Unit Weight:270g

P&Q CURVE (AT RATED VOLTAGE)

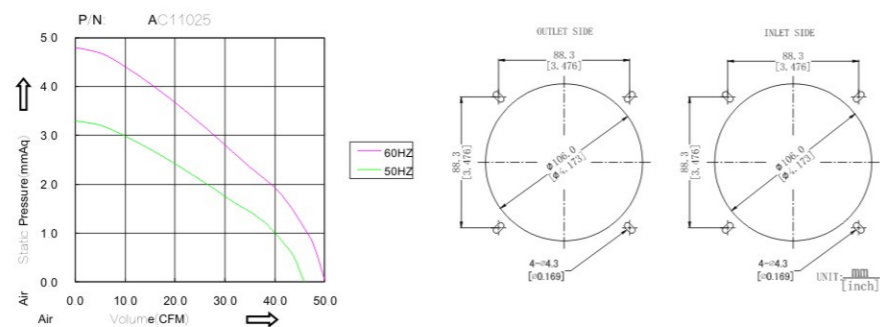

Part Number	Voltage(V)	Frequency (HZ)	Power (W)	Current (Amp)	Speed (RPM)	Air flow(Q)	Pressure(P)	Noise(dBA)		
产品编号	电压	频率	功率	电流	转速	(CFM) 风量	(mmAq)风压 (In H <sub>2</sub> O)	噪音		
AC11025S110H	AC 110/120	50/60	18/17	0.20/0.18	2200/2500	46/50	1.3/1.4	3.0/4.6	0.12/0.18	36/38
AC11025B110H		50/60	18/17	0.20/0.18	2200/2500	46/50	1.3/1.4	3.3/4.8	0.13/0.19	36/38
AC11025S220H	AC 220/240	50/60	18/17	0.10/0.09	2200/2500	46/50	1.3/1.4	3.0/4.6	0.12/0.18	36/38
AC11025B220H		50/60	18/17	0.10/0.09	2200/2500	46/50	1.3/1.4	3.3/4.8	0.13/0.19	36/38

- ★ 如果您需要的转速或电压或功能不在这份清单上, 请与我们联系。  
If you want another rpm or voltage or functions which one is not in the list, please contact with our sales.
- ★ 提示1:功能的具体信息参照产品目录前页篇章。  
Notes1:The catalog have detail information in the front page for the functions.
- ★ 提示2:产品详细信息请参照承认书。  
Notes2:Product have a detail in the approval sheet.
- ★ 提示3:产品规格变更不另行通知。  
Notes3:Specifications are subject to change without notice.

# STANDARD AC AXIAL FAN



## 120\*120\*25mm

### AC12025 Series



DIMENSIONS DRAWING

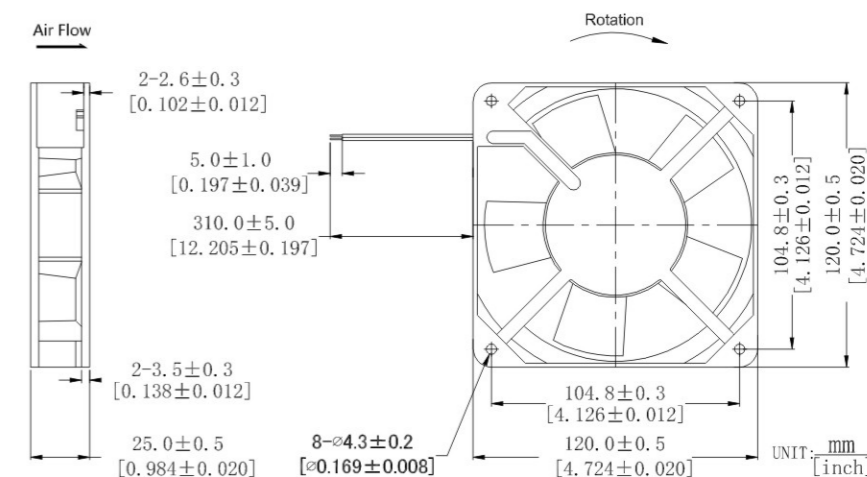

外框材质:铝合金  
Frame:Aluminum  
扇叶材质:环保防火PBT  
Impeller:Thermoplastic PBT UL94-V0  
轴承结构:双滚珠或长寿命含油结构  
Bearing system:2Ball or Long life sleeve  
单体风扇重量:280g  
Unit Weight:280g

P&Q CURVE (AT RATED VOLTAGE)

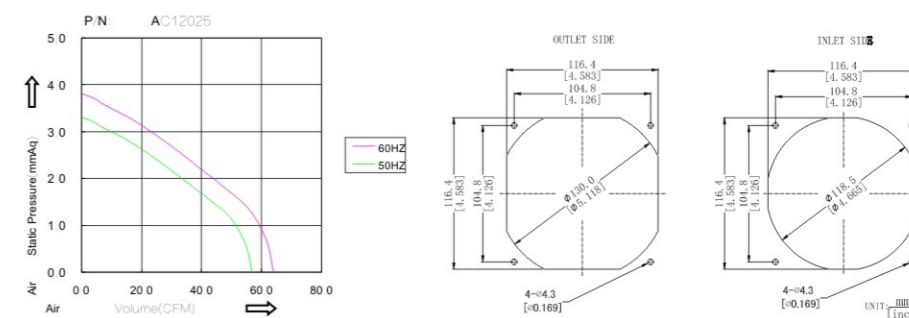

Part Number	Voltage(V)	Frequency (HZ)	Power (W)	Current (Amp)	Speed (RPM)	Air flow(Q)	Pressure(P)	Noise(dBA)		
产品编号	电压	频率	功率	电流	转速	(CFM) 风量	(mmAq)风压 (In H <sub>2</sub> O)	噪音		
AC12025S110H	AC 110/120	50/60	18/16	0.20/0.18	2200/2500	57/64	1.6/1.8	3.3/3.8	0.13/0.15	40/45
AC12025B110H		50/60	18/16	0.20/0.18	2200/2500	57/64	1.6/1.8	3.3/3.8	0.13/0.15	40/45
AC12025S220H	AC 220/240	50/60	18/16	0.10/0.09	2200/2500	57/64	1.6/1.8	3.3/3.8	0.13/0.15	40/45
AC12025B220H		50/60	18/16	0.10/0.09	2200/2500	57/64	1.6/1.8	3.3/3.8	0.13/0.15	40/45

- ★ 如果您需要的转速或电压或功能不在这份清单上, 请与我们联系。  
If you want another rpm or voltage or functions which one is not in the list, please contact with our sales.
- ★ 提示1:功能的具体信息参照产品目录前页篇章。  
Notes1:The catalog have detail information in the front page for the functions.
- ★ 提示2:产品详细信息请参照承认书。  
Notes2:Product have a detail in the approval sheet.
- ★ 提示3:产品规格变更不另行通知。  
Notes3:Specifications are subject to change without notice.

# STANDARD AC AXIAL FAN



## 120\*120\*38mm AC12038 Series



节能的高性价比 Energy-save and Cost Effective

DIMENSIONS DRAWING

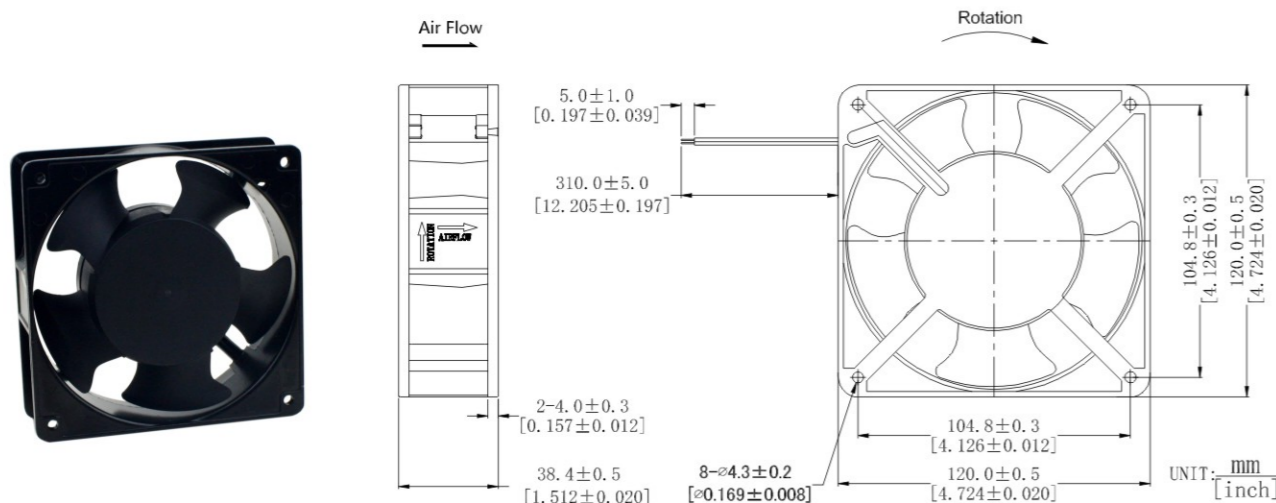

外框材质:铝合金  
 Frame:Aluminum  
 扇叶材质:环保防火PBT  
 Imperller:Thermoplastic PBT UL94-V0  
 轴承结构:双滚珠或长寿命含油结构  
 Bearing system:2Ball or Long life sleeve  
 单体风扇重量:500g  
 Unit Weight:500g

P&Q CURVE (AT RATED VOLTAGE)

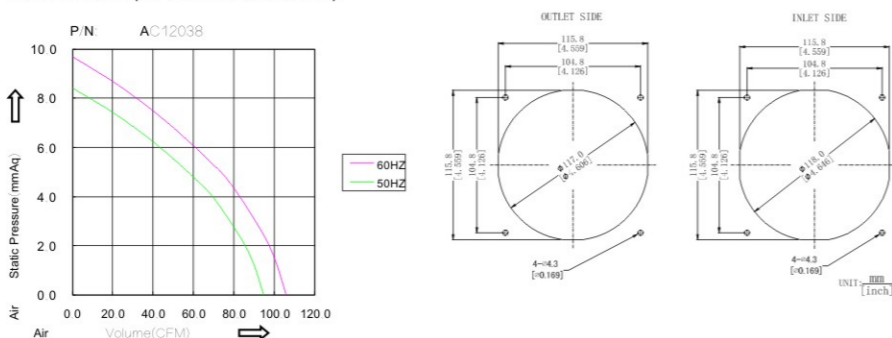

Part Number	Voltage(V)	Frequency (HZ)	Power (W)	Current (Amp)	Speed (RPM)	Air flow(Q)	Pressure(P)	Noise(dBA)		
产品编号	电压	频率	功率	电流	转速	(CFM) 风量	(mmAq)风压 (In H <sub>2</sub> O)	噪音		
AC12038S110H	AC 110/120	50/60	20/19	0.26/0.24	2500/2700	84/95	2.4/2.7	8.4/9.7	0.33/0.38	44/49
AC12038B110H		50/60	20/19	0.26/0.24	2500/2700	84/95	2.4/2.7	8.4/9.7	0.33/0.38	44/49
AC12038S220H	AC 220/240	50/60	20/19	0.13/0.12	2500/2700	84/95	2.4/2.7	8.4/9.7	0.33/0.38	44/49
AC12038B220H		50/60	20/19	0.13/0.12	2500/2700	84/95	2.4/2.7	8.4/9.7	0.33/0.38	44/49
AC12038S380H	AC 380	50/60	20/19	0.08/0.07	2500/2700	84/95	2.4/2.7	8.4/9.7	0.33/0.38	44/49
AC12038B380H		50/60	20/19	0.08/0.07	2500/2700	84/95	2.4/2.7	8.4/9.7	0.33/0.38	44/49

- ★ 如果您需要的转速或电压或功能不在这份清单上, 请与我们联系。  
If you want another rpm or voltage or functions which one is not in the list, please contact with our sales.
- ★ 提示1:功能的具体信息参照产品目录前页篇章。  
Notes1:The catalog have detail information in the front page for the functions.
- ★ 提示2:产品详细信息请参照承认书。  
Notes2:Product have a detail in the approval sheet.
- ★ 提示3:产品规格变更不另行通知。  
Notes3:Specifications are subject to change without notice.

# STANDARD AC AXIAL FAN



## 150\*150\*51mm AC15051 Series



DIMENSIONS DRAWING

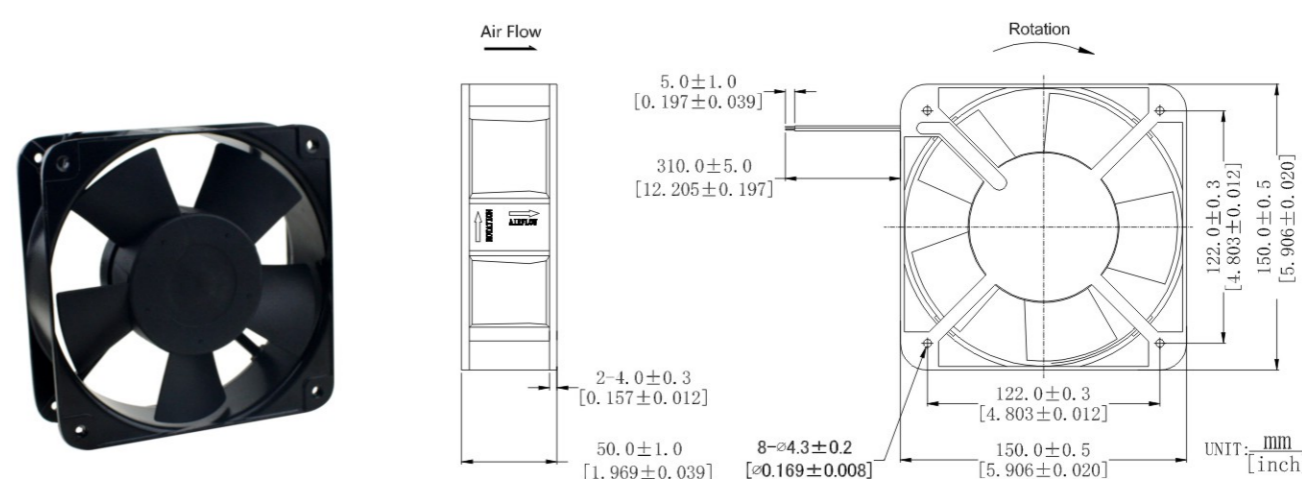

外框材质:铝合金  
 Frame:Aluminum  
 扇叶材质:环保防火PBT  
 Imperller:Thermoplastic PBT UL94-V0  
 轴承结构:双滚珠或长寿命含油结构  
 Bearing system:2Ball or Long life sleeve  
 单体风扇重量:900g  
 Unit Weight:900g

P&Q CURVE (AT RATED VOLTAGE)

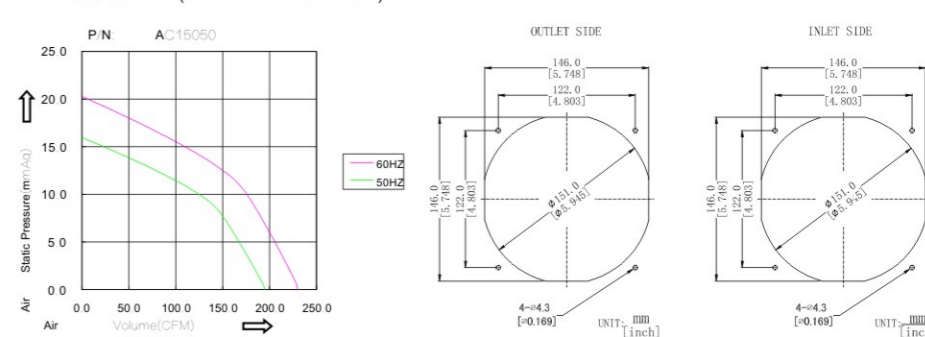

Part Number	Voltage(V)	Frequency (HZ)	Power (W)	Current (Amp)	Speed (RPM)	Air flow(Q)	Pressure(P)	Noise(dBA)		
产品编号	电压	频率	功率	电流	转速	(CFM) 风量	(mmAq)风压 (In H <sub>2</sub> O)	噪音		
AC15050S110H	AC 110/120	50/60	34/32	0.50/0.45	2400/2600	195/230	5.5/6.5	16.0/20.3	0.63/0.80	50/55
AC15050B110H		50/60	34/32	0.50/0.45	2400/2600	195/230	5.5/6.5	16.0/20.3	0.63/0.80	50/55
AC15050S220H	AC 220/240	50/60	34/32	0.23/0.21	2400/2600	195/230	5.5/6.5	16.0/20.3	0.63/0.80	50/55
AC15050B220H		50/60	34/32	0.23/0.21	2400/2600	195/230	5.5/6.5	16.0/20.3	0.63/0.80	50/55
AC15050S380H	AC 380	50/60	36/34	0.15/0.14	2400/2600	195/230	5.5/6.5	16.0/20.3	0.63/0.80	50/55
AC15050B380H		50/60	36/34	0.15/0.14	2400/2600	195/230	5.5/6.5	16.0/20.3	0.63/0.80	50/55

- ★ 如果您需要的转速或电压或功能不在这份清单上, 请与我们联系。  
If you want another rpm or voltage or functions which one is not in the list, please contact with our sales.
- ★ 提示1:功能的具体信息参照产品目录前页篇章。  
Notes1:The catalog have detail information in the front page for the functions.
- ★ 提示2:产品详细信息请参照承认书。  
Notes2:Product have a detail in the approval sheet.
- ★ 提示3:产品规格变更不另行通知。  
Notes3:Specifications are subject to change without notice.

# STANDARD AC AXIAL FAN



## 172\*150\*51mm AC17251 Series



DIMENSIONS DRAWING

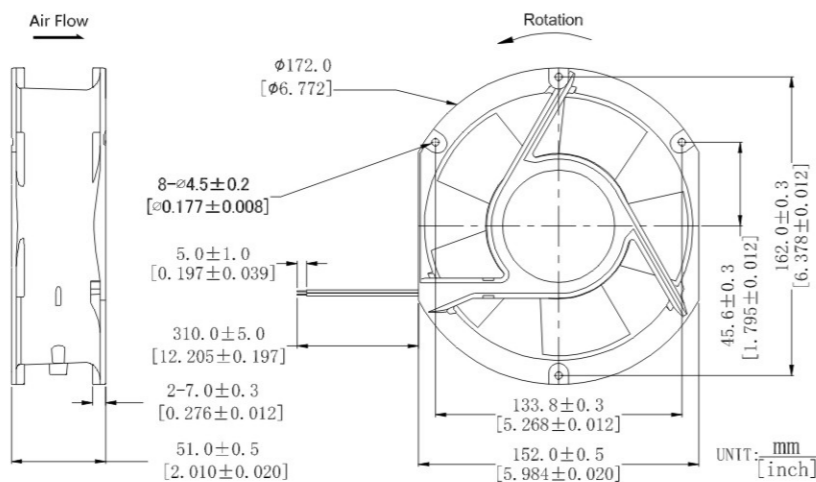

外框材质:铝合金  
Frame:Aluminum  
扇叶材质:环保防火PBT  
Impeller:Thermoplastic PBT UL94-V0  
轴承结构:双滚珠或长寿命含油结构  
Bearing system:2Ball or Long life sleeve  
单体风扇重量:880g  
Unit Weight:880g

P&Q CURVE (AT RATED VOLTAGE)

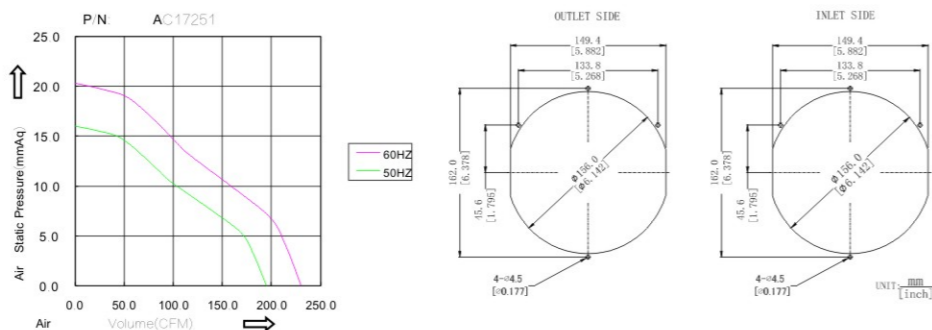

Part Number	Voltage(V)	Frequency (HZ)	Power (W)	Current (Amp)	Speed (RPM)	Air flow(Q)	Pressure(P)	Noise(dBA)	
产品编号	电压	频率	功率	电流	转速	(CFM) 风量 m <sup>3</sup> /min	(mmAq)风压 (In H <sub>2</sub> O)	噪音	
AC17251A110H	AC 110/120	50/60	34/32	0.50/0.45	2400/2600	195/230	5.5/6.5 16.0/20.3	0.63/0.80	50/55
AC17251B110H		50/60	34/32	0.50/0.45	2400/2600	195/230	5.5/6.5 16.0/20.3	0.63/0.80	50/55
AC17251A220H	AC 220/240	50/60	34/32	0.23/0.21	2400/2600	195/230	5.5/6.5 16.0/20.3	0.63/0.80	50/55
AC17251B220H		50/60	34/32	0.23/0.21	2400/2600	195/230	5.5/6.5 16.0/20.3	0.63/0.80	50/55
AC17251A380H	AC 380	50/60	36/34	0.15/0.14	2400/2600	195/230	5.5/6.5 16.0/20.3	0.63/0.80	50/55
AC17251B380H		50/60	36/34	0.15/0.14	2400/2600	195/230	5.5/6.5 16.0/20.3	0.63/0.80	50/55

★如果您需要的转速或电压或功能不在这份清单上, 请与我们联系。  
If you want another rpm or voltage or functions which one is not in the list, please contact with our sales.

★提示1:功能的具体信息参照产品目录前页篇章。  
Notes1:The catalog have detail information in the front page for the functions.

★提示2:产品详细信息请参照承认书。  
Notes2:Product have a detail in the approval sheet.

★提示3:产品规格变更不另行通知。  
Notes3:Specifications are subject to change without notice.

# STANDARD AC AXIAL FAN



## 180\*180\*60mm AC18060 Series



DIMENSIONS DRAWING

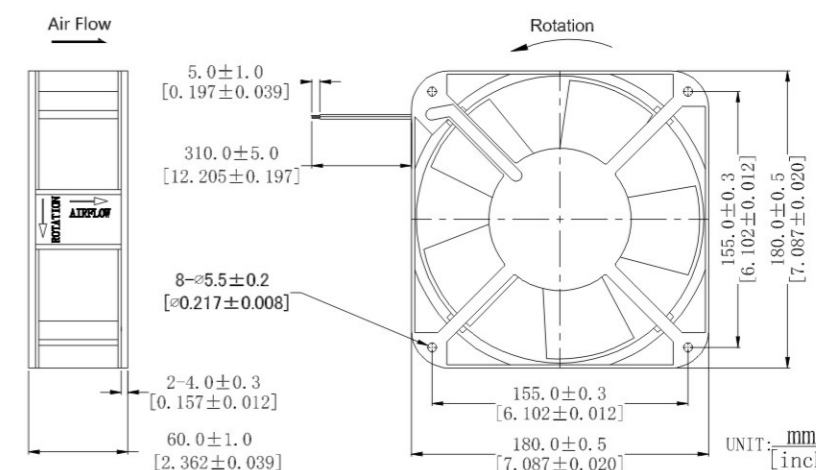

外框材质:铝合金  
Frame:Aluminum  
扇叶材质:环保防火PBT  
Impeller:Thermoplastic PBT UL94-V0  
轴承结构:双滚珠或长寿命含油结构  
Bearing system:2Ball or Long life sleeve  
单体风扇重量:1550g  
Unit Weight:1550g

P&Q CURVE (AT RATED VOLTAGE)

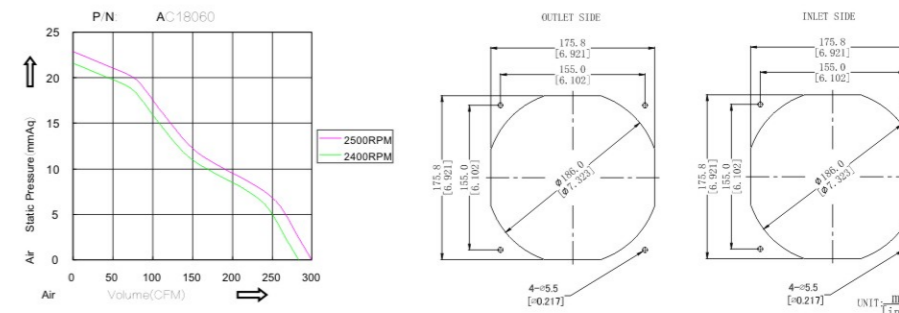

Part Number	Voltage(V)	Frequency (HZ)	Power(W)	Current (Amp)	Speed(RPM)	Air flow(Q)	Pressure(P)	Noise(dBA)	
产品编号	电压	频率	功率	电流	转速	(CFM) 风量 m <sup>3</sup> /min	(mmAq)风压 (In H <sub>2</sub> O)	噪音	
AC18060B110H	AC 110/120	50/60	50	0.70	2500	300	8.50 22.86	0.90	65
AC18060B220H	AC 220/240	50/60	50	0.35	2500	300	8.50 22.86	0.90	65
AC18060B380H	AC 380	50/60	50	0.18	2400	283	8.00 21.60	0.85	65

★如果您需要的转速或电压或功能不在这份清单上, 请与我们联系。  
If you want another rpm or voltage or functions which one is not in the list, please contact with our sales.

★提示1:功能的具体信息参照产品目录前页篇章。  
Notes1:The catalog have detail information in the front page for the functions.

★提示2:产品详细信息请参照承认书。  
Notes2:Product have a detail in the approval sheet.

★提示3:产品规格变更不另行通知。  
Notes3:Specifications are subject to change without notice.

# STANDARD AC AXIAL FAN

## 200\*200\*60mm AC20060 Series



DIMENSIONS DRAWING

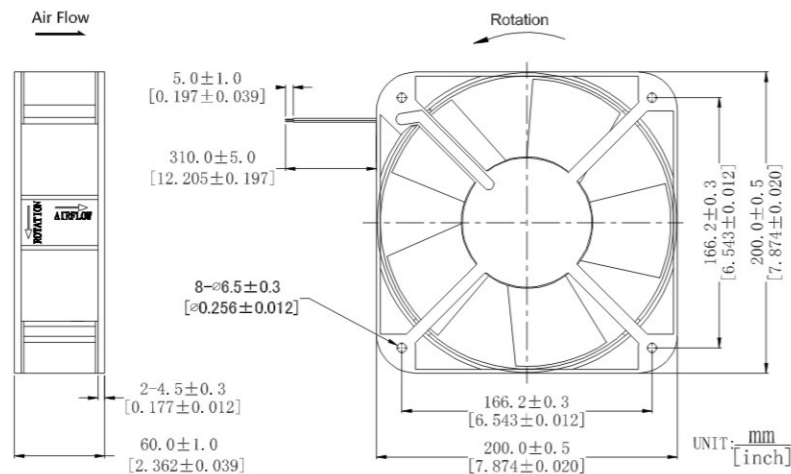

外框材质:铝合金  
Frame:Aluminum  
扇叶材质:环保防火PBT  
Impeller:Thermoplastic PBT UL94-V0  
轴承结构:双滚珠或长寿命含油结构  
Bearing system:2Ball or Long life sleeve  
单体风扇重量:1625g  
Unit Weight:1625g

P&Q CURVE (AT RATED VOLTAGE)

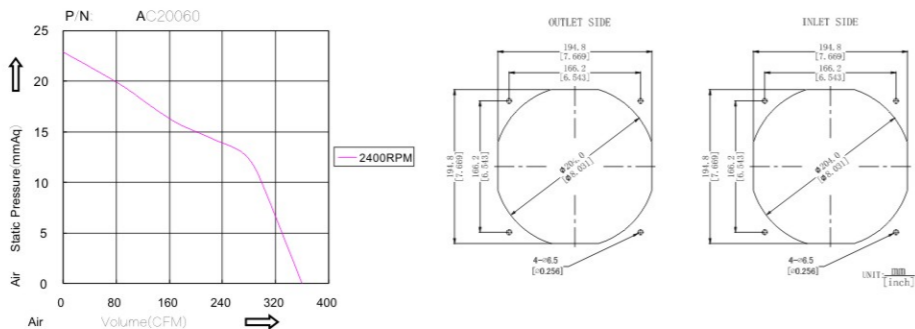

Part Number	Voltage(V)	Frequency (HZ)	Power(W)	Current (Amp)	Speed(RPM)	Air flow(Q)	Pressure(P)	Noise(dBA)
产品编号	电压	频率	功率	电流	转速	(CFM) 风量	m <sup>3</sup> /min (mmAq)风压 (In H <sub>2</sub> O)	噪音
AC20060B110H	AC 110/120	50/60	47	0.50	2400	360	10.20 22.86 0.90	56
AC20060B220H	AC 220/240	50/60	42	0.32	2400	360	10.20 22.86 0.90	56
AC20060B380H	AC 380	50/60	40	0.17	2400	360	10.20 22.86 0.90	56

★ 如果您需要的转速或电压或功能不在这份清单上, 请与我们联系。  
If you want another rpm or voltage or functions which one is not in the list, please contact with our sales.

★ 提示1:功能的具体信息参照产品目录前页篇章。  
Notes1:The catalog have detail information in the front page for the functions.

★ 提示2:产品详细信息请参照承认书。  
Notes2:Product have a detail in the approval sheet.

★ 提示3:产品规格变更不另行通知。  
Notes3:Specifications are subject to change without notice.

# STANDARD AC AXIAL FAN

## 254\*89mm AC25489 Series



DIMENSIONS DRAWING

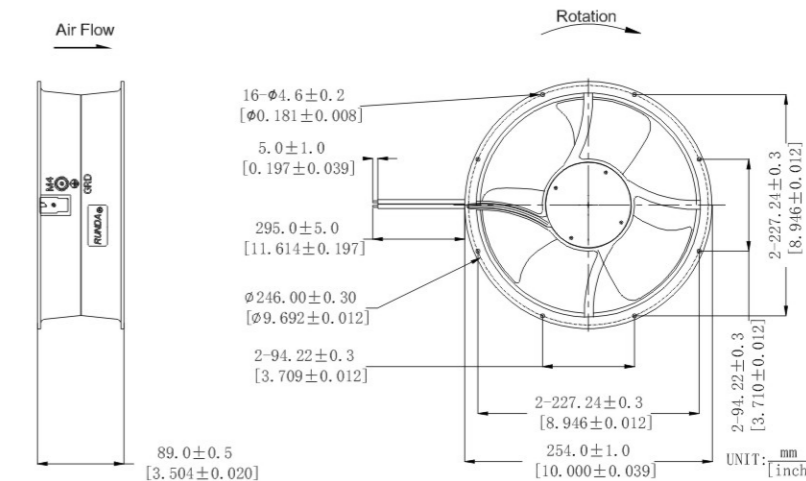

外框材质:铝合金  
Frame:Aluminum  
扇叶材质:环保防火PBT  
Impeller:Thermoplastic PBT UL94-V0  
轴承结构:双滚珠或长寿命含油结构  
Bearing system:2Ball or Long life sleeve  
单体风扇重量:2410g  
Unit Weight:2410g

P&Q CURVE (AT RATED VOLTAGE)

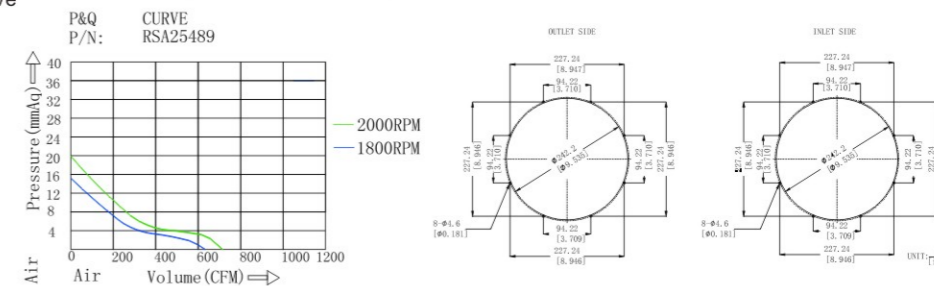

Part Number	Voltage(V)	Frequency (HZ)	Power(W)	Current (Amp)	Speed (RPM)	Air flow(Q)	Pressure(P)
产品编号	电压	频率	功率	电流	转速	(CFM) 风量	m <sup>3</sup> /min (mmAq)风压 (In H <sub>2</sub> O)
AC25489B110H	AC 110/120	50/60	35/30	0.32/0.30	1800/2000	620/680	17.5/19.2 12.7/14.0 0.50/0.55
AC25489B220H	AC 220/240	50/60	33/31	0.15/0.14	1800/2000	620/680	17.5/19.2 12.7/14.0 0.50/0.55

★ 如果您需要的转速或电压或功能不在这份清单上, 请与我们联系。  
If you want another rpm or voltage or functions which one is not in the list, please contact with our sales.

★ 提示1:功能的具体信息参照产品目录前页篇章。  
Notes1:The catalog have detail information in the front page for the functions.

★ 提示2:产品详细信息请参照承认书。  
Notes2:Product have a detail in the approval sheet.

★ 提示3:产品规格变更不另行通知。  
Notes3:Specifications are subject to change without notice.

金属护网系列  
Metal Finger Guard Series

RM-XX Series

塑胶滤网系列  
Plastic Filter Guard Series

RP-XX Series

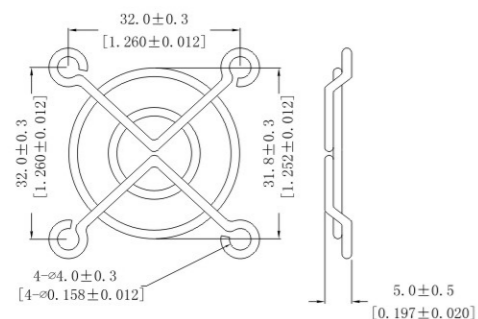

4CM网罩

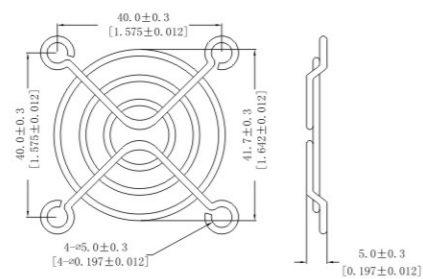

5CM网罩

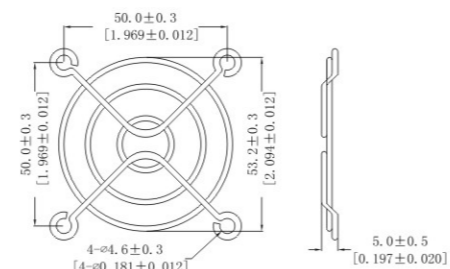

6CM网罩

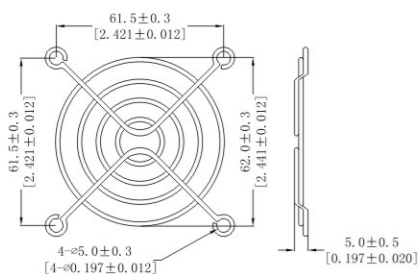

7CM网罩

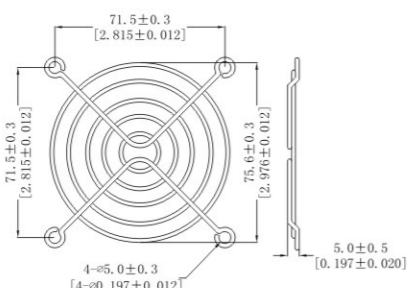

8CM网罩

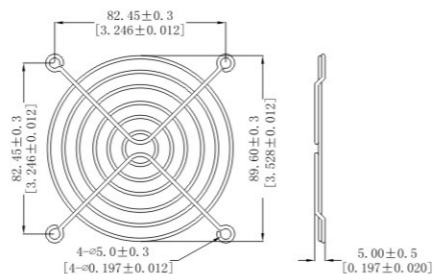

9CM网罩

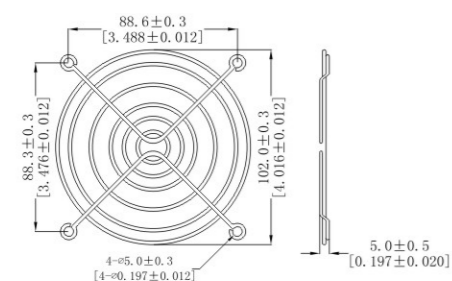

11CM网罩

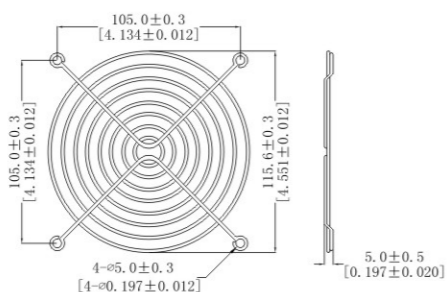

12CM网罩

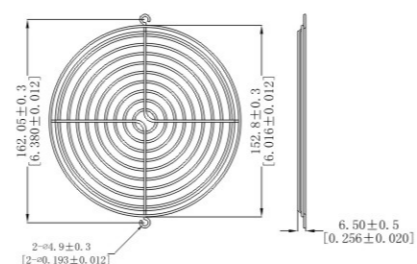

15CM二脚网罩

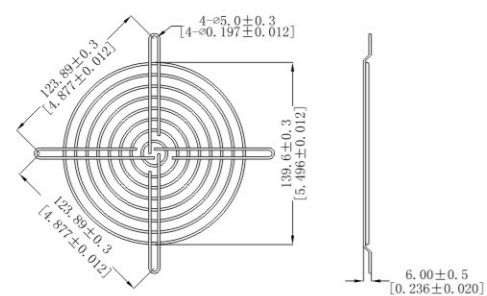

15CM四脚网罩

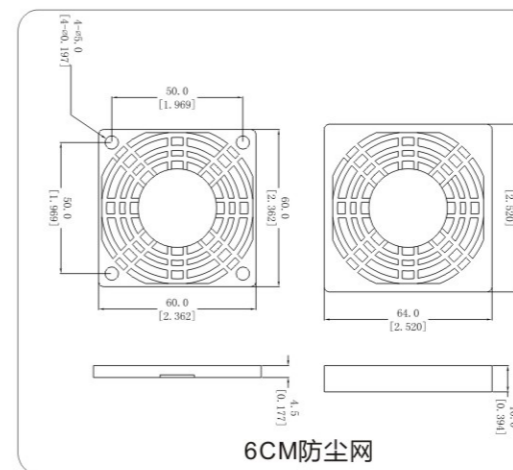

6CM防尘网

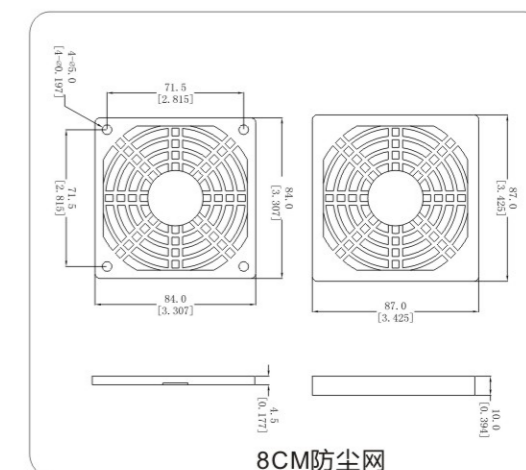

8CM防尘网

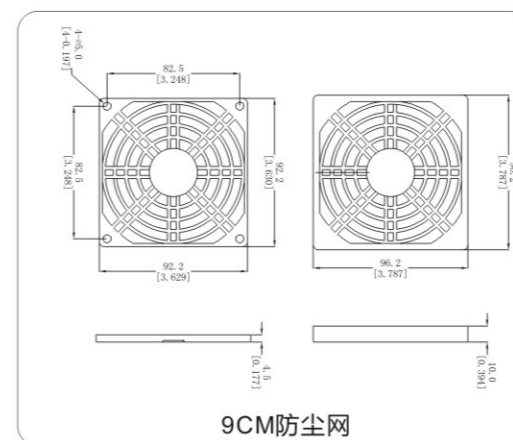

9CM防尘网

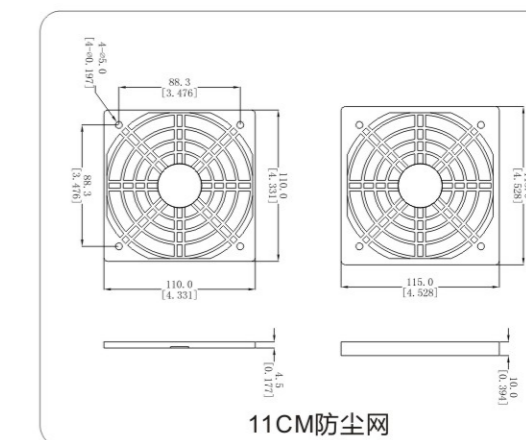

11CM防尘网

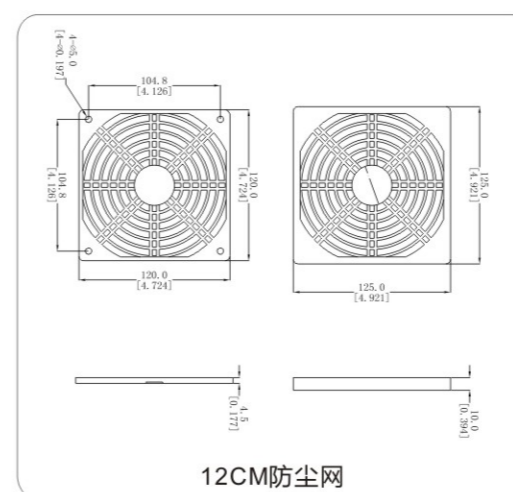

12CM防尘网



17CM防尘网