

1. Scope

This specification applies to the HPIH series of SMD power inductor .

2. Product Identification

$\frac{\text{HPIH}}{\text{①}}$ $\frac{201610}{\text{②}}$ $\frac{1R0}{\text{③}}$ $\frac{M}{\text{④}}$ - $\frac{LF}{\text{⑤}}$

- ① Product Symbol
- ② Product dimensions
- ③ Inductance Value (R47:0.47 uH; 1R0: 1.0uH; 100:10uH)
- ④ Inductance Tolerance (M: $\pm 20\%$)
- ⑤ Lead free product.

3. Appearance and Dimensions

3.1 Appearance and dimensions

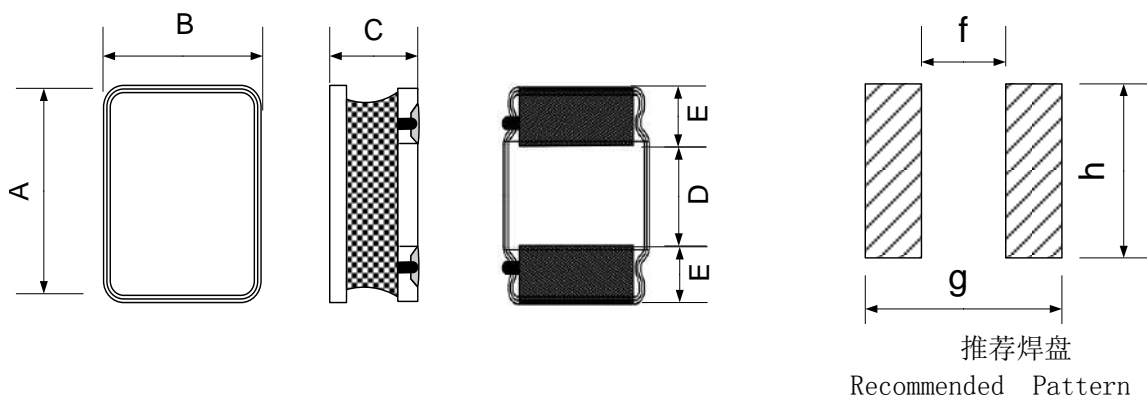

Dimensions in mm								
Model	A	B	C	D	E	f	g	h
HPIH201610	2.00 \pm 0.20	1.60 \pm 0.20	1.00Max.	0.60 \pm 0.2	0.60 \pm 0.2	0.80 Typ.	2.20 Typ.	1.60 Typ.
HPIH252010	2.50 \pm 0.20	2.00 \pm 0.20	1.00Max.	0.80 \pm 0.2	0.80 \pm 0.2	0.80 Typ.	2.50 Typ.	2.00 Typ.
HPIH252012	2.50 \pm 0.20	2.00 \pm 0.20	1.20Max.	0.80 \pm 0.2	0.80 \pm 0.2	0.80 Typ.	2.50 Typ.	2.00 Typ.

3.2 Material List

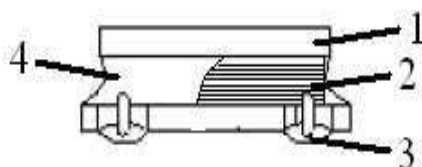

No.	Item	Material
1	Core	Ni-Zn Ferrite
2	Wire	Enameled Copper Wire
3	Terminal Electrode	Ag/Ni/Sn/Cu
4	Magnetic Glue	Epoxy resin and magnetic powder

4. Testing Conditions

Unless otherwise specified

Temperature : Ordinary Temperature (5 to 35°C)

Humidity : Ordinary Humidity (25 to 85% RH)

Atmospheric Pressure : 86 to 106 kPa

In case of doubt

Temperature : 20±2°C

Humidity : 60 to 75% RH

Atmospheric Pressure : 86 to 106 kPa

5. Electrical Characteristic

Hongda Part No.	Inductance (uH)	DCR(Ω)		Isat (A)		Irms (A)	
		Max	Typ	Max	Typ	Max	Typ
HPIH201610-R24M-LF	0.24±20%	0.032	0.025	3.80	4.20	3.70	4.30
HPIH201610-R33M-LF	0.33±20%	0.041	0.034	3.50	3.80	3.50	3.80
HPIH201610-R47M-LF	0.47±20%	0.041	0.034	2.35	3.00	2.80	3.00
HPIH201610-R68M-LF	0.68±20%	0.060	0.050	2.20	2.60	2.60	2.80
HPIH201610-1R0M-LF	1.0±20%	0.072	0.060	1.70	2.00	2.00	2.25
HPIH201610-2R2M-LF	2.2±20%	0.215	0.175	1.10	1.35	1.25	1.40
HPIH201610-3R3M-LF	3.3±20%	0.380	0.316	1.00	1.30	0.95	1.05
HPIH201610-4R7M-LF	4.7±20%	0.420	0.340	0.90	1.00	0.90	1.00
HPIH201610-6R8M-LF	6.8±20%	0.660	0.550	0.70	0.80	0.70	0.80
HPIH201610-100M-LF	10±20%	0.820	0.680	0.60	0.65	0.60	0.70



Hongda Part No.	Inductance (uH)	DCR(Ω)		Isat (A)		Irms (A)	
		Max	Typ	Max	Typ	Max	Typ
HPIH252010-R47M-LF	0.47±20%	0.042	0.035	3.40	3.60	3.20	3.50
HPIH252010-R68M-LF	0.68±20%	0.058	0.045	2.80	3.20	2.75	3.20
HPIH252010-1R0M-LF	1.0±20%	0.072	0.055	2.00	2.70	2.45	2.70
HPIH252010-1R5M-LF	1.5±20%	0.108	0.090	1.80	2.00	1.80	2.00
HPIH252010-2R2M-LF	2.2±20%	0.142	0.115	1.55	1.70	1.55	1.75
HPIH252010-3R3M-LF	3.3±20%	0.270	0.225	1.45	1.50	1.15	1.25
HPIH252010-4R7M-LF	4.7±20%	0.330	0.275	1.15	1.25	1.00	1.10

Hongda Part No.	Inductance (uH)	DCR(Ω)		Isat (A)		Irms (A)	
		Max	Typ	Max	Typ	Max	Typ
HPIH252012-R24M-LF	0.24 \pm 20%	0.026	0.022	5.40	5.80	3.80	4.00
HPIH252012-R33M-LF	0.33 \pm 20%	0.030	0.025	4.95	5.05	4.95	5.25
HPIH252012-R47M-LF	0.47 \pm 20%	0.032	0.027	4.20	4.50	3.40	3.75
HPIH252012-R68M-LF	0.68 \pm 20%	0.045	0.037	3.50	4.00	3.20	3.50
HPIH252012-1R0M-LF	1.0 \pm 20%	0.056	0.045	2.60	3.00	2.70	3.50
HPIH252012-1R5M-LF	1.5 \pm 20%	0.072	0.060	2.10	2.30	2.10	2.25
HPIH252012-2R2M-LF	2.2 \pm 20%	0.100	0.085	1.60	1.90	2.08	2.20
HPIH252012-3R3M-LF	3.3 \pm 20%	0.144	0.120	1.50	1.70	1.50	1.60
HPIH252012-4R7M-LF	4.7 \pm 20%	0.216	0.180	1.25	1.40	1.20	1.35
HPIH252012-6R8M-LF	6.8 \pm 20%	0.300	0.250	1.10	1.20	0.95	1.05
HPIH252012-100M-LF	10 \pm 20%	0.462	0.385	0.90	1.00	080	0.90

Test instruments and remarks

- * CHROMA 3302 meter for L.
- *Tonghui TH2516B meter for DCR
- * CHROMA 3302 and 1320meter for IDC.
- * L test condition: 1.0MHz/1V.
- * Isat:Based on inductance change ($|L_I-L|/L \leq 30\%$)
- * Irms:Based on temperature rise($\Delta T:40^\circ\text{C}$ TYP).

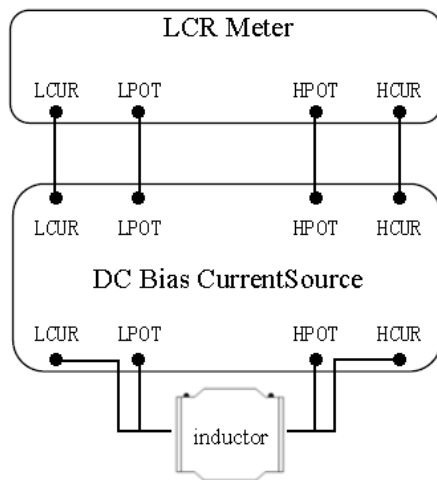

Isat test schematic diagram

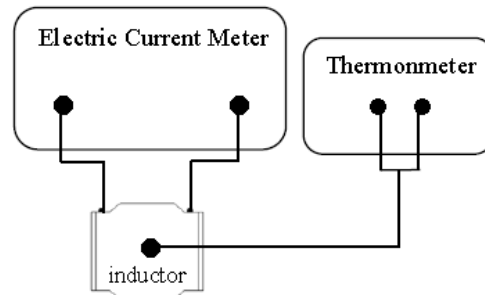

Irms test schematic diagram

6. Condition of work

Operating temperature range: $-25^\circ\text{C} \sim +120^\circ\text{C}$.(Including self-heating)

7. Reliability and Test Condition

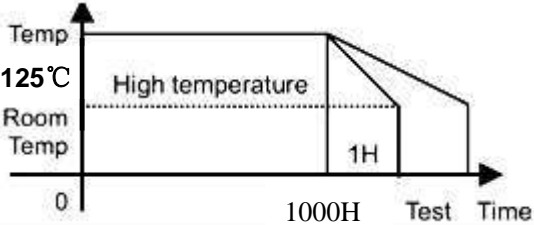
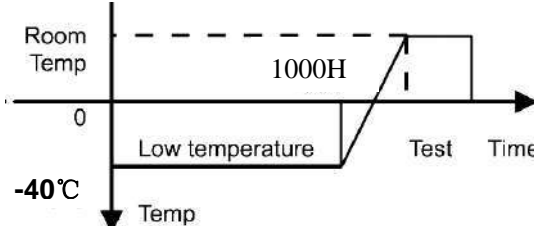
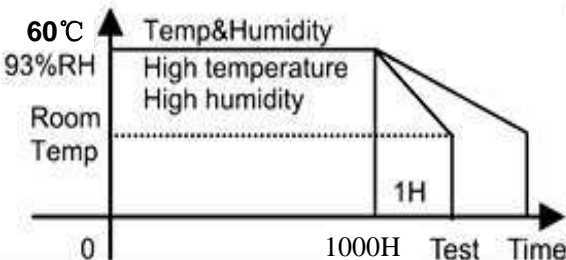
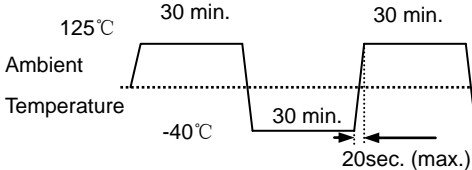
Item	Required Characteristics	Test Method/Condition
High temperature resistance		Temperature: $125 \pm 2^\circ\text{C}$ Time : 1000 hours Tested not less than 1 hours, nor more than 2 hours at room temperature. 
Low temperature resistance	1. No case deformation or change in appearance. 2. $ \Delta L /L \leq 10\%$	Temperature : $-40 \pm 2^\circ\text{C}$ Time : 1000 hours Tested not less than 1 hour, nor more than 2 hours at room temperature. 
Humidity test		1. Exposure : Temperature: $60 \pm 2^\circ\text{C}$, Humidity : $93 \pm 3\%$ RH Time : 1000 hours. 2. Tested while the specimens are still in the chamber. 3. Tested not less than 1 hour, nor more than 2 hours at room temperature. 
Thermal shock test	1. No case deformation or change in appearance. 2. $ \Delta L /L \leq 10\%$	First -40°C for T time, last 125°C T time as 1 cycle. Go through 100 cycles. 

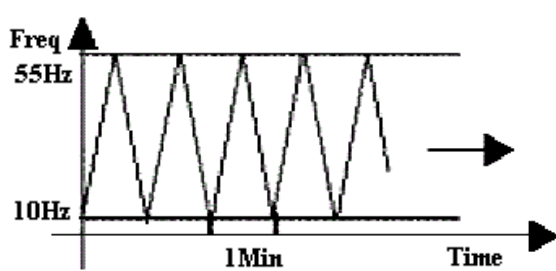
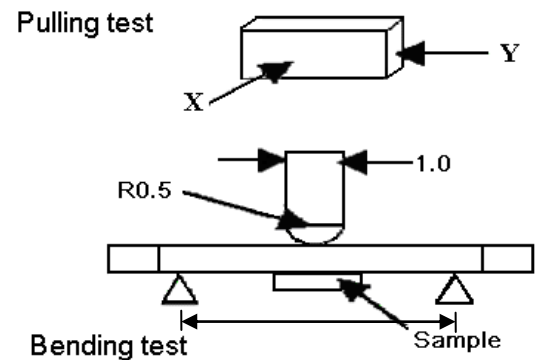
Item	Required Characteristics	Test Method/Condition
Solderability test	Terminal area must have 90% min. solder coverage.	Dip pads in flux then dip in solder pot at $245 \pm 5^\circ\text{C}$ for <5 second. Solder: lead free Flux: rosin flux.
Heat endurance of reflow soldering		Refer to the next page reflow curve Go through 3 times. The peak temperature: $260+5/-0^\circ\text{C}$
Vibration test	1. No case deformation or change in appearance. 2. $ \Delta L /L \leq 10\%$	Apply frequency 10~55Hz. 1.5mm amplitude in each of perpendicular direction for 2 hours in each 3 mutually perpendicular directions.(total 6 hours) 
Drop test		Packaged & drop down from 1m with $981\text{m/s}^2(100\text{G})$ attitude in 1 angle 1 ridges & 2surfaces orientations.
Terminal strength push test	Pulling test: Define: Solder the products on testing PCB using eutectic solder. Then apply a force in the direction of the arrow. 10N force. Keep time $\geq 5\text{s}$ Bending test: Soldering the products on PCB, after the pulling test and bending test, terminal should not pull off.	Bend the testing PCB at middle point, the deflection shall be 2mm. Pressurizing Speed: 0.5mm/sec, Keep time: $30 \pm 1\text{s}$, 
Resistance to solvent test	No case deformation or change in appearance, or obliteration of marking	To dip parts into IPA solvent for 50.5Min, then drying them at room temp for 5Min., at last, to brushing marking 10 times.
Loading Under Humidity Heat	1. No case deformation or change in appearance. 2. $ \Delta L /L \leq 10\%$	1. Exposure : Temperature: $60 \pm 2^\circ\text{C}$, Humidity : $93 \pm 3\%$ RH Time : 1000 hours. Apply rated current 2. Tested while the specimens are still in the chamber. 3. Tested not less than 1 hour, nor more than 2 hours at room temperature.
Loading at High Temperature	1. No case deformation or change in appearance. 2. $ \Delta L /L \leq 10\%$	1. Temperature: $85 \pm 2^\circ\text{C}$ 2. Time : 1000 hours 3. Apply rated current 4. Tested not less than 1 hours, nor more than 2 hours at room temperature.

8. Recommended Soldering Conditions

Product can be applied to flow and reflow soldering.

(1) Flux, Solder

- ① Use rosin-based flux. Don't use highly acidic flux with halide content exceeding 0.2wt% (chlorine conversion value).
- ② Use Sn solder.

(2) Reflow soldering conditions

Reflow curve

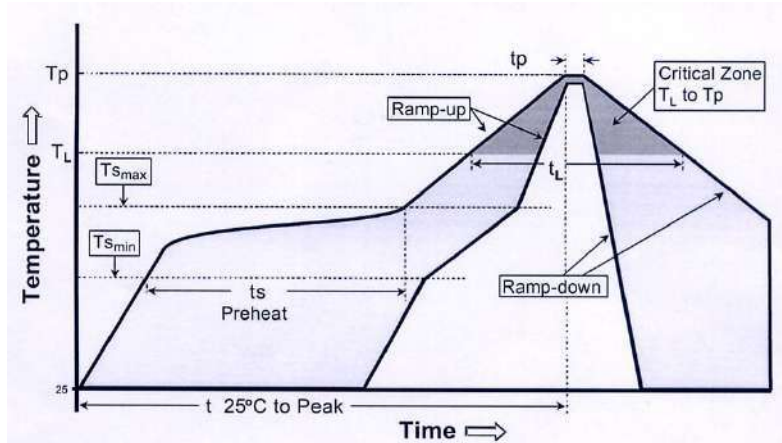

Profile Feature		Lead-Free Assembly
Average Ramp-Up Rate (Ts max. to Tp)		3°C /second max.
Preheat	- Temperature Min (Ts min.)	150 °C
	- Temperature Max (Ts max.)	200 °C
	- Time (ts min to ts max.)	60-180 seconds
Time maintained above	- Temperature (TL)	217 °C
	- Time (tL)	60-150 seconds
Peak/Classification Temperature (Tp)		260 °C
Peak/Classification Time (Tp)		10 seconds
Time within 5 °C of actual Peak Temperature (Tp)		20-40 seconds
Ramp-Down Rate		6 °C/second max.
Time 25 °C to Peak Temperature		8 minutes max.

Note 1: All temperatures refer to topside of the package, measured on the package body surface.

(3) The method on Re-work with using the iron:

The following conditions must be strictly followed when using a soldering iron

Pre-heating	150°C, 1 minute
Tip temperature	350°C max
Soldering iron output	80w max
End of soldering iron	φ1mm max
Soldering time	3 seconds max

Product once removes from the circuit board may not be used again.

9. Package Information

9.1 Dimension of tape (Unit: mm)

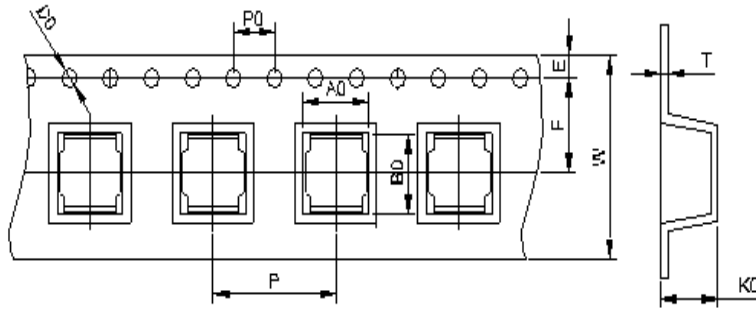

W	A0	B0	K0	E	F	P	P0	D0	T
8.0±0.3	2.40±0.10	2.80±0.10	1.35±0.1	1.75±0.1	3.5±0.05	4.0±0.1	4.0±0.1	1.5+0.1/-0.0	0.18±0.03

9.2 Dimension of reel (Unit: mm)

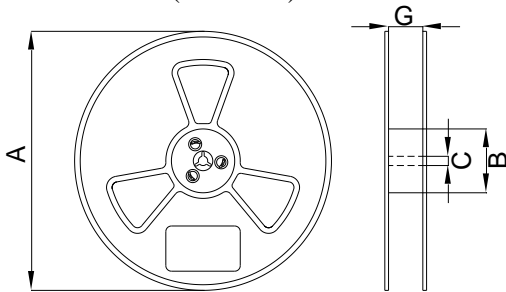

Symbol	Dimension
A	178±2
B	58±2
C	13.5±0.2
G	9.0±1.5

9.3 Taping figure and drawing direction

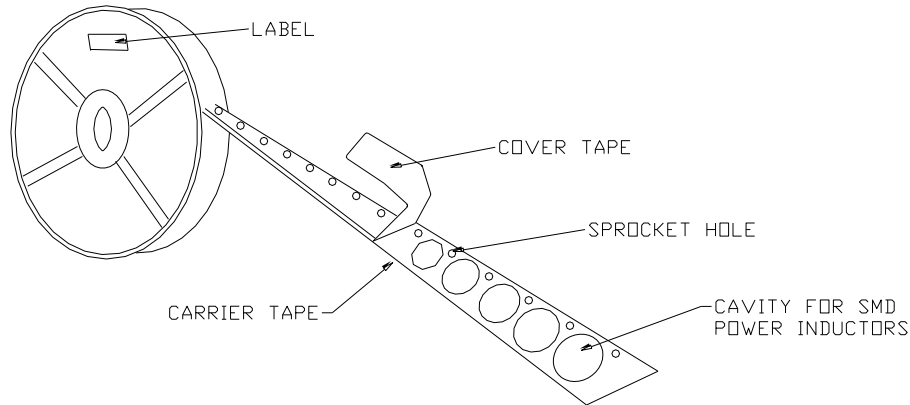

9.4 Packaging quantities: 2000PCS/Reel.

9.5 Peeling strength of cover tape:

The peel force of top cover tape shall be between 0.15N to 0.65N

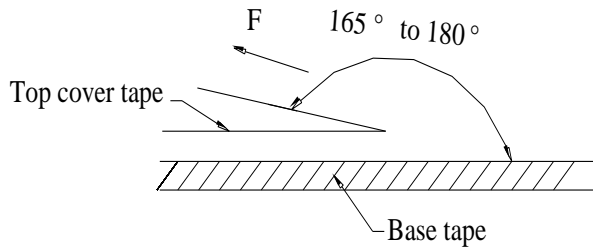

Room Temp. (°C)	Room Humidity (%)	Room aim (hpa)	Peel Speed Mm/min
5-35	45-85	860-1060	300

10. Visual inspection standard of product

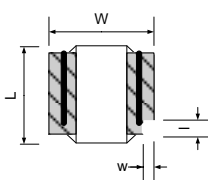
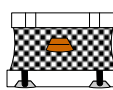
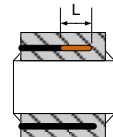
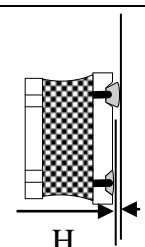
No.	Defect Item	Graphic	Rejection identification	Acceptance
1	Core defect		$l > L/6$ or $w > W/6$, NG.	AQL=0.65
2	Missing resin		The area of missing resin more than single face, NG	AQL=0.65
3	Cold solder		L more than 1 mm, NG.	AQL=0.65
4	Solder uneven		$H > 0.1\text{mm}$. NG.	AQL=0.65

10. Products Storage

(1) Storage period

Products which inspected in HONGDA over 12 months ago should be examined and used, which can be confirmed with inspection No. marked on the container. Solderability should be checked if this period is exceeded.

(2) Storage conditions

Products should be storage in the warehouse on the following conditions:

Temperature: -10 ~+ 35°C

Humidity: Less than 70% relative and humidity

No rapid change on temperature and humidity.

(3) Don't keep products in corrosive gases such as sulfur, chlorine gas or acid, or it may cause oxidization of electrode, resulting in poor solderability.

(4) Products should be storage on the palette for the prevention of the influence from humidity, dust and so on.

(5) Products should be storage in the warehouse without heat shock, vibration, direct sunlight and so on.

(6) Products should be storage under the airtight packaged condition.