



MAP1608FT Series

Specification

Product Name	Power Inductor
Series	MAP 1608FT Series
Size	EIAJ 1608



Multilayer Power Inductor (MAP-FT Series) Engineering Spec.

This product belongs to the 3C and industrial grade standard, not for automotive application. If customer privately uses to automotive parts and results in any consequences, INPAQ is not responsible for after-sales service, thank you!

■ Features

- The monolithic construction performs high reliability and ensures a closed magnetic flux in a component avoids magnetic leakage and interference .
- Allow for higher mounting density.
- Low DC resistance.

■ Applications

Suitable for DVD , DSC , PND , PC , NB , Power Line

■ Shapes and Dimensions

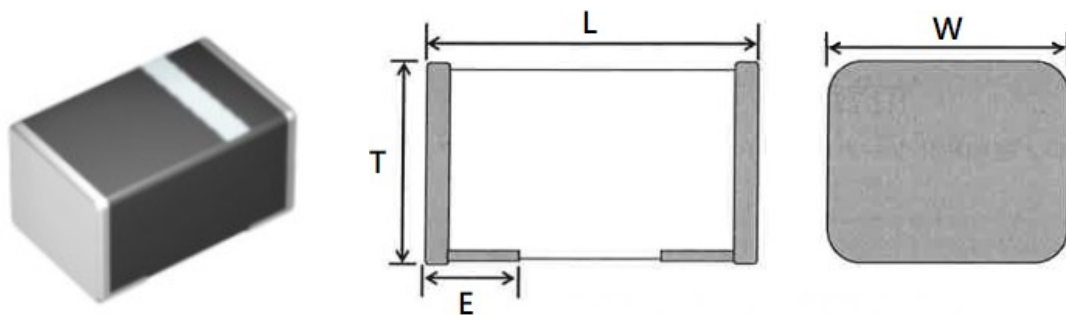

Type (mm)	1608 (EIA0603)
L	1.60±0.20
W	0.80±0.20
T	1.00 Max.
E	0.30±0.20

■ **Part Number and Characteristics Table**

Part Number.	Inductance ±20% (μH)	DCR (Ω)		Rated Current I _{rms} (mA)		Rated Current I _{sat} (mA)	
		Typ.	Max.	Typ.	Max.	Typ.	Max.
MAP1608FTR24MME	0.24	0.035	0.038	2900	2600	3200	2800
MAP1608FTR47MME	0.47	0.044	0.055	2300	2000	2800	2400
MAP1608FT1R0MME	1.00	0.100	0.123	1500	1300	2400	2000
Item	Test Method						
Inductance	<ul style="list-style-type: none"> •Agilent E4991A RF Impedance Material Analyzer or equivalent •Agilent 16192A fixture or equivalent •Test Frequency : 1MHz •Test Level : 100 mV 						
DC Resistance	•HP4338A/B Milliohm meter						

** For special part number which is not shown in the above table, please refer to appendix.

■ **Part Number Code**

MAP 1608 F T R47 M M E
 1 2 3 4 5 6 7 8

- 1 Series Name
- 2 Size Code : The first two digitals: length(mm) · the last two digitals: width(mm)
- 3 Internal Code
- 4 Type code
- 5 Inductance : R = Decimal point · Unit = μH
- 6 Tolerance : M = ±20%
- 7 Polarity Marking : M = with ; N = without
- 8 Packaging : E = Embossed plastic tape, 7" reel.

■ **Tape and Reel Specifications**

Plastic Carrier (E)

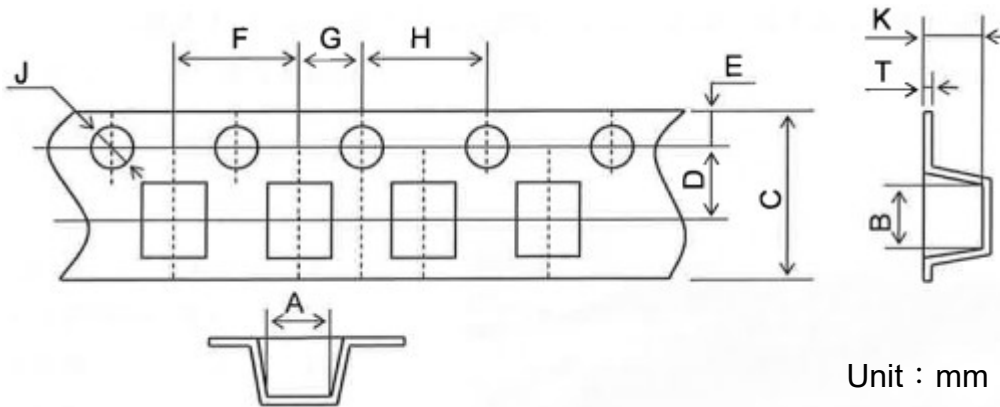

Taping Dimensions

Size(mm)	1608
Symbol	PLASTIC
A	1.15±0.10
B	1.95±0.10
C	8.00±0.20
D	3.50±0.05
E	1.75±0.10
F	4.00±0.10
G	2.00±0.05
H	4.00±0.10
J	1.50+0.1/-0
T	0.25±0.05
K	1.20 max.

■ Reel Dimensions

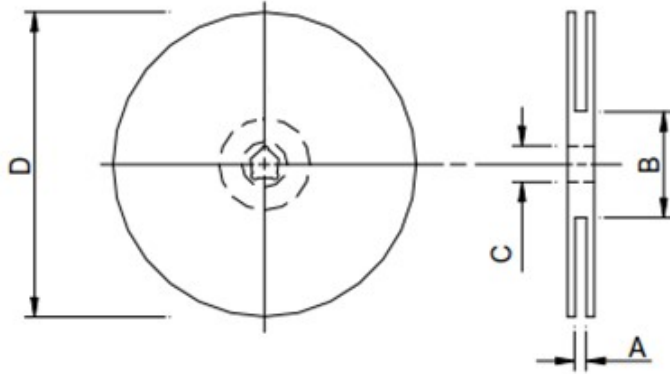

Type	A(mm)	B(mm)	C(mm)	D(mm)
7"	10±1.5	50 or more	13.2±1.0	178±2.0

■ Packaging Dimension And Quantity

Packaging style : Taping

Reel packaging quantity : **3,000** pcs/reel

Per the box : 5 Reels

■ Recommended Soldering Conditions

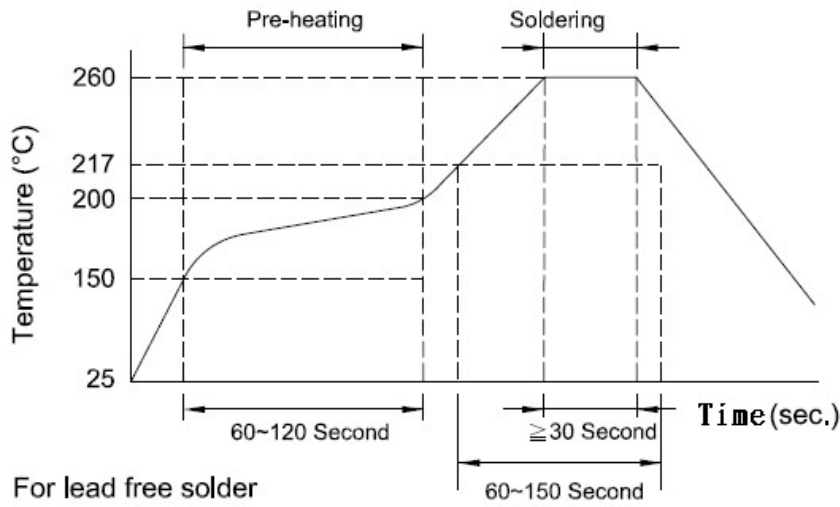

■ Land Patterns for Reflow Soldering

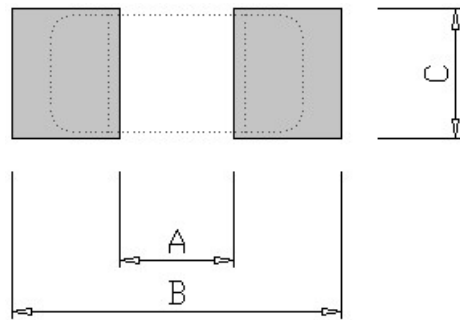

Size(mm)	A	B	C
1608	1.00 (0.039)	1.90 (0.075)	1.00 (0.039)

■ Reliability and Test Conditions

Test item	Test condition	Criteria
Resistance to Solder Heat	<ol style="list-style-type: none"> Solder temperature : $260 \pm 5^{\circ}\text{C}$ Flux : Rosin DIP time : 10 ± 1 sec 	<ol style="list-style-type: none"> No mechanical damage Inductance value should be within $\pm 10\%$ of the initial value
Solderability	<ol style="list-style-type: none"> Solder temperature : $235 \pm 5^{\circ}\text{C}$ Flux : Rosin DIP time : 5 ± 1 sec 	<ol style="list-style-type: none"> More than 90 % of terminal electrode should be covered with new solder
Adhesive Test	<ol style="list-style-type: none"> Reflow temperature : 245°C It shall be soldered on the substrate applying direction parallel to the substrate Apply force(F) : 10 N Test time : 5 sec 	<ol style="list-style-type: none"> No mechanical damage Soldering the products on PCB after the pulling test force > 10 N
Thermal Shock	<ol style="list-style-type: none"> Temperature: $-40 \sim 85^{\circ}\text{C}$ for 30 minutes each Cycle: 100 cycles Measurement: at ambient temperature 24 hours after test completion 	<ol style="list-style-type: none"> No mechanical damage Inductance should be within $\pm 10\%$ of the initial value
High Temperature Resistance	<ol style="list-style-type: none"> Temperature: $85 \pm 5^{\circ}\text{C}$ Testing time: 500 hrs Measurement: at ambient temperature 24 hours after test completion 	<ol style="list-style-type: none"> No mechanical damage Inductance should be within $\pm 10\%$ of the initial value
Humidity	<ol style="list-style-type: none"> Temperature: $40^{\circ}\text{C} \pm 2^{\circ}\text{C}$ Humidity: 90-95 % RH Testing time: 500 hrs Measurement: at ambient temperature 24 hours after test completion 	<ol style="list-style-type: none"> No mechanical damage Inductance should be within $\pm 10\%$ of the initial value

Test item	Test condition	Criteria
Rated Current	Apply current : full rated current / 5min	MAP product surface temp : below room temperature plus 40°C

■ **GENERAL TECHNICAL DATA**

Operating temperature range : - 40°C ~ +125°C

Storage Condition : Less than 40°C and 70% RH

Soldering method : Reflow