



## WFI1608FT Series

# Data Sheet

<b>Product Name</b>	<b>WFI1608FT Series</b>
<b>Series</b>	<b>Chip Inductor</b>
<b>Size</b>	<b>EIAJ 1608</b>
<b>Version</b>	<b>A0</b>

1. SCOPE

- 1.1. Ferrite core wire wound construction.
- 1.2. High Reliability due to wire wound type construction.
- 1.3. Inductance values from 0.047 to 10  $\mu$ H.
- 1.4. Application for DC power line.

2. PART NUMBERING IDENTIFICATION

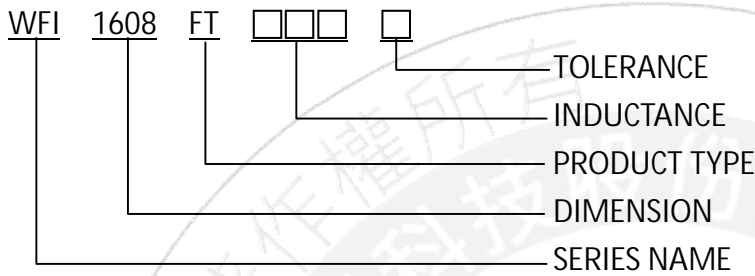

3. MECHANICAL DIMENSION

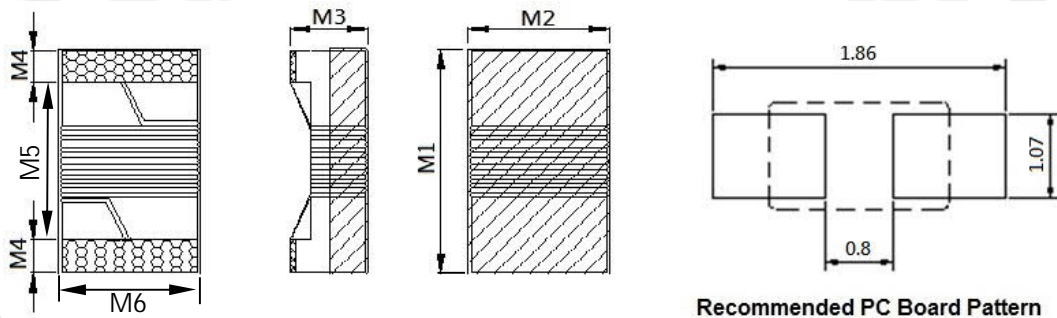

Series	M1	M2	M3	M4	M5	M6
WFI1608FT	1.65±0.15	1.15±0.15	1.05±0.15	0.35±0.10	0.85±0.10	0.90±0.10

4. RATING TEMPERATURE

OPERATING TEMPERATURE RANGE: -40°C TO +125°C (Including self - temperature rise).  
 STORAGE TEMPERATURE RANGE: -40°C TO +85°C (on board).

### 5. STRUCTURE

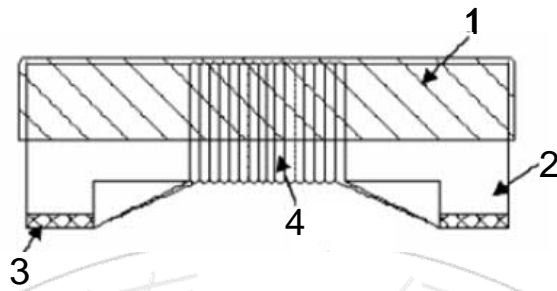

### 6. MATERIAL LIST

ITEM	MATERIAL CATEGORY	MATERIAL TYPE
1	EPOXY	UV TYPE
2	CORE	FERRITE
3	TERMINATION	Ag+Ni+Sn
4	WIRE	ENAMELED COPPER WIRE

### 7. TEST INSTRUMENT

7-1 Inductance、Q : TEST BY KEYSIGHT 4991B or equivalent.

7-2 SRF : TEST BY KEYSIGHT 4991B or equivalent.

7-3 DC Resistance : TEST BY CHROMA 16502 or equivalent.

### 8. ELECTRICAL SPECIFICATION

Part number	Inductance (μH)	Tolerance	Test Frequency (MHz)	Q TYP.	Test Frequency (MHz)	SRF (MHz) MIN.	DC Resistance (Ω) MAX.	IDC (mA) MAX.
WFI1608FT47N□	0.047	K,J	0.5V/7.9	17	7.9	1500	0.075	1500
WFI1608FT72N□	0.072	K	0.5V/7.9	17	7.9	1300	0.12	1500
WFI1608FTR10□	0.10	K,J	0.5V/7.9	17	7.9	1100	0.12	1500
WFI1608FTR15□	0.15	K	0.5V/7.9	17	7.9	1050	0.15	1450
WFI1608FTR18□	0.18	K	0.5V/7.9	17	7.9	1030	0.15	1400
WFI1608FTR33□	0.33	K	0.5V/7.9	17	7.9	670	0.46	900
WFI1608FTR39□	0.39	K	0.5V/7.9	17	7.9	650	0.51	1100
WFI1608FTR47□	0.47	K	0.5V/7.9	17	7.9	560	0.62	1050
WFI1608FTR56□	0.56	K	0.5V/7.9	17	7.9	520	0.44	850
WFI1608FTR68□	0.68	K	0.5V/7.9	17	7.9	500	0.52	850
WFI1608FTR82□	0.82	K	0.5V/7.9	17	7.9	460	0.69	750
WFI1608FTR91□	0.91	K	0.5V/7.9	17	7.9	260	0.76	670
WFI1608FT1R0□	1.0	K	0.5V/7.9	17	7.9	275	0.81	600
WFI1608FT1R2□	1.2	K	0.5V/7.9	17	7.9	295	0.87	550
WFI1608FT1R5□	1.5	K	0.5V/7.9	17	7.9	215	1.06	540
WFI1608FT1R8□	1.8	K	0.5V/7.9	17	7.9	155	1.1	520
WFI1608FT2R2□	2.2	K	0.5V/7.9	17	7.9	70	1.2	500
WFI1608FT2R7□	2.7	K	0.5V/7.9	17	7.9	90	1.5	480
WFI1608FT3R3□	3.3	K	0.5V/7.9	17	7.9	80	1.5	440
WFI1608FT3R9□	3.9	K	0.5V/7.9	17	7.9	70	1.6	430
WFI1608FT4R7□	4.7	K, J	0.5V/7.9	18	7.9	63	2.1	420
WFI1608FT5R6□	5.6	K, J	0.5V/7.9	18	7.9	60	2.6	350
WFI1608FT6R8□	6.8	K, J	0.5V/7.9	19	7.9	50	3.1	330
WFI1608FT7R8□	7.8	K, J	0.5V/7.9	17	7.9	36	3.5	320
WFI1608FT8R2□	8.2	K, J	0.5V/7.9	17	7.9	36	3.8	300
WFI1608FT100□	10	K, J	0.5V/7.9	19	7.9	30	4.8	270

NOTE:

- Tolerance: K:±10%、J:±5%
- IDC Applied the current to coils, the inductance change shall be less than 20% to initial value.
- MSL: Level 1

9. ELECTRICAL CURVE

Inductance vs. Frequency

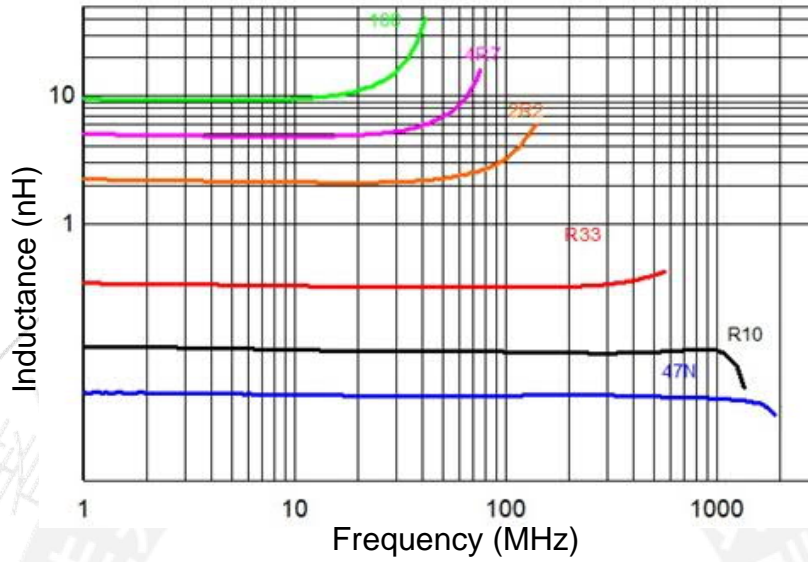

Typical Q vs. Frequency

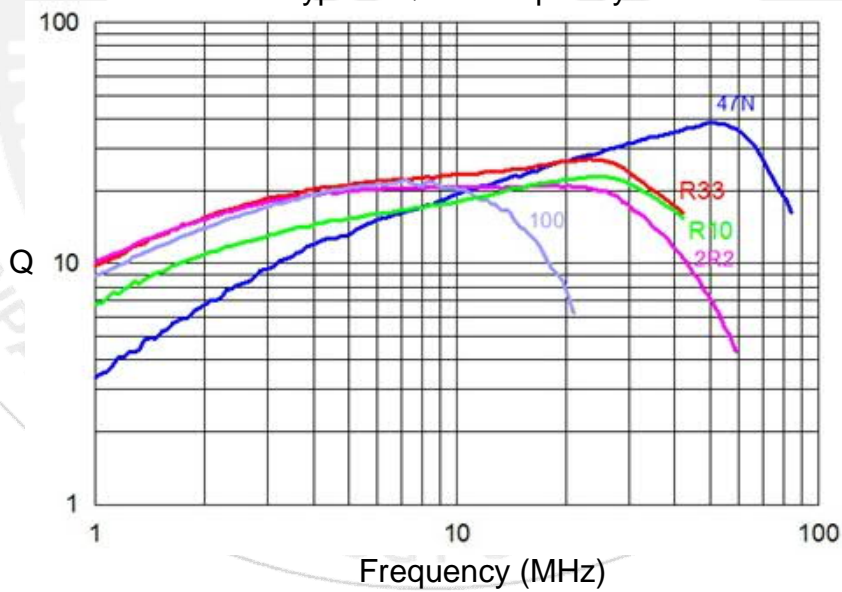

10. RELIABILITY PERFORMANCE

Item	Performance	Test Condition
Life Test		Preconditioning: Run through IR reflow for 2 times. (IPC/JEDEC J-STD-020D Classification Reflow Profiles) Temperature: 125±2°C Applied current: rated current Duration: 1000±12hrs Measured at room temperature after placing for 24±2 hrs.
Load Humidity		Preconditioning: Run through IR reflow for 2 times. (IPC/JEDEC J-STD-020D Classification Reflow Profiles) Humidity: 85±2% R.H. Temperature: 85°C±2°C Duration: 1000hrs Min. with 100% rated current Measured at room temperature after placing for 24±2 hrs.
Moisture Resistance	Appearance: No damage. Inductance: within ±10% of initial value Q: Shall not exceed the specification value RDC: within ±15% of initial value and shall not exceed the specification value	Preconditioning: Run through IR reflow for 2 times. (IPC/JEDEC J-STD-020D Classification Reflow Profiles) 1. Baked at 50°C for 25hrs, measured at room temperature after placing for 4 hrs. 2. Raise temperature to 65±2°C 90-100%RH in 2.5hrs, and keep 3 hours, cool down to 25°C in 2.5hrs. 3. Raise temperature to 65±2°C 90-100%RH in 2.5hrs, and keep 3 hours, cool down to 25°C in 2.5hrs, keep at 25°C for 2 hrs then keep at -10°C for 3 hrs 4. Keep at 25°C 80-100%RH for 15min and vibrate at the frequency of 10 to 55 Hz to 10 Hz, measure at room temperature after placing for 1~2 hrs.
Thermal shock		Preconditioning: Run through IR reflow for 2 times. (IPC/JEDEC J-STD-020D Classification Reflow Profiles) Condition for 1 cycle Step1: -40±2°C 30±5min Step2: 25±2°C ≤0.5min Step3: 125±2°C 30±5min Number of cycles: 500 Measured at room temperature after placing for 24±2 hrs
Vibration		Oscillation Frequency: 10~2K~10Hz for 20 minutes Equipment: Vibration checker Total Amplitude: 10g Testing Time: 12 hours (20 minutes, 12 cycles each of 3 orientations)

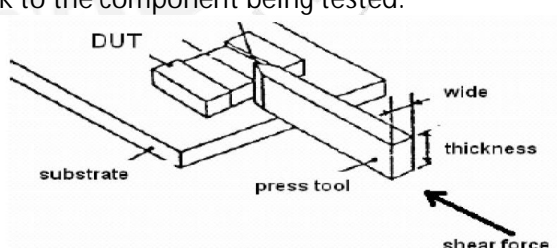
Item	Performance	Test Condition															
Bending	Appearance: No damage. Inductance: within±10% of initial value Q: Shall not exceed the specification value	Shall be mounted on a FR4 substrate of the following dimensions: >=0805 inch(2012mm): 40x100x1.2mm <0805 inch(2012mm):40x100x0.8mm Bending depth: >=0805 inch(2012mm):1.2mm <0805 inch(2012mm):0.8mm duration of 10 sec.															
Shock	RDC: within ±15% of initial value and shall not exceed the specification value	<table border="1"> <thead> <tr> <th>Type</th> <th>Peak value (g's)</th> <th>Normal duration (D) (ms)</th> <th>Wave form</th> <th>Velocity change (Vi)ft/sec</th> </tr> </thead> <tbody> <tr> <td>SMD</td> <td>50</td> <td>11</td> <td>Half-sine</td> <td>11.3</td> </tr> <tr> <td>Lead</td> <td>50</td> <td>11</td> <td>Half-sine</td> <td>11.3</td> </tr> </tbody> </table>	Type	Peak value (g's)	Normal duration (D) (ms)	Wave form	Velocity change (Vi)ft/sec	SMD	50	11	Half-sine	11.3	Lead	50	11	Half-sine	11.3
Type	Peak value (g's)	Normal duration (D) (ms)	Wave form	Velocity change (Vi)ft/sec													
SMD	50	11	Half-sine	11.3													
Lead	50	11	Half-sine	11.3													
Solder ability	More than 95% of the terminal electrode should be covered with solder	Preheat: 150°C,60sec. Solder: Sn96.5% Ag3% Cu0.5% Temperature: 245±5°C Flux for lead free: Rosin. 9.5% Dip time: 4±1sec Depth: completely cover the termination															
Resistance to Soldering Heat		Depth: completely cover the termination <table border="1"> <thead> <tr> <th>Temperature(°C)</th> <th>Time(s)</th> <th>Temperature ramp/immersion and emersion rate</th> <th>Number of heat cycles</th> </tr> </thead> <tbody> <tr> <td>260 ±5 (solder temp)</td> <td>10±1</td> <td>25mm/s ±6 mm/s</td> <td>1</td> </tr> </tbody> </table>	Temperature(°C)	Time(s)	Temperature ramp/immersion and emersion rate	Number of heat cycles	260 ±5 (solder temp)	10±1	25mm/s ±6 mm/s	1							
Temperature(°C)	Time(s)	Temperature ramp/immersion and emersion rate	Number of heat cycles														
260 ±5 (solder temp)	10±1	25mm/s ±6 mm/s	1														
Terminal Strength	Appearance: No damage. Inductance: within±10% of initial value Q: Shall not exceed the specification value RDC: within ±15% of initial value and shall not exceed the specification value	Preconditioning: Run through IR reflow for 2 times. (IPC/JEDEC J-STD-020DClassification Reflow Profiles) With the component mounted on a PCB with the device to be tested, apply a force (>0805: 1kg, <=0805:0.5kg) to the side of a device being tested. This force shall be applied for 60+1 seconds. Also the force shall be applied gradually as not to apply a shock to the component being tested. 															

11. REFLOW CHART

**Typical RoHS Reflow Profile**

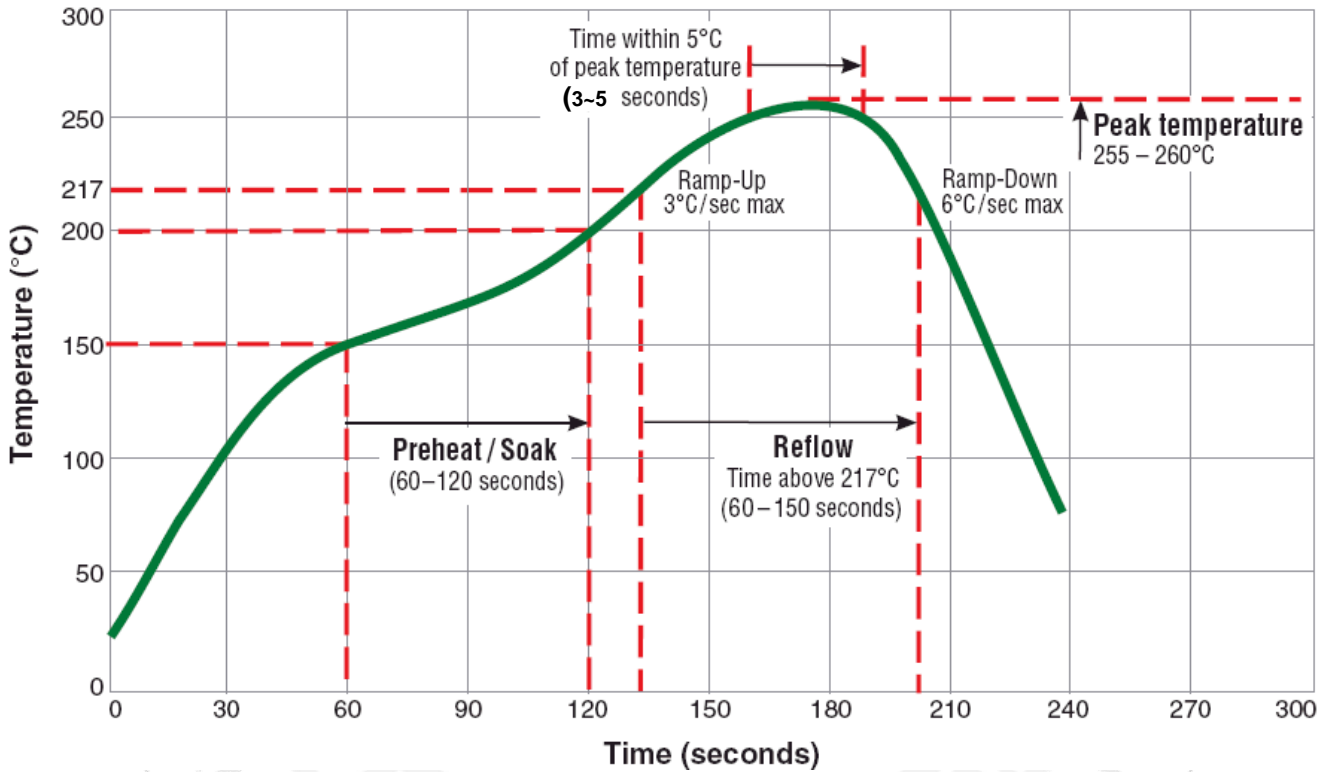

12. PACKING

12-1. Reel Dimension

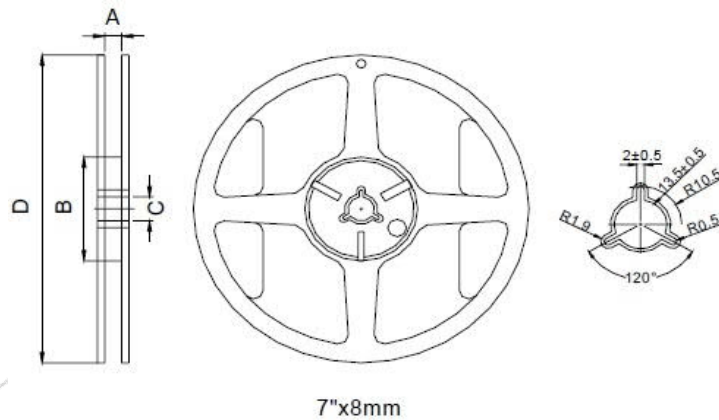

UNIT:mm

A	B	C	D
9.0±0.5	60±2	13.5±0.5	178±2

12-2. Tape Dimension / 8mm(black anti-static electricity carrier tape)

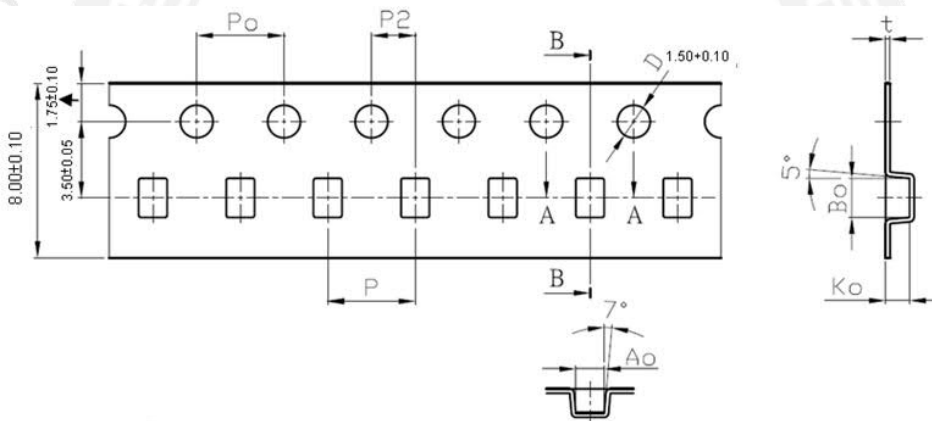

UNIT:mm

P	Po	P2	Bo	Ao	Ko	t
4.00±0.10	4.00±0.10	2.00±0.1	2.00±0.1	1.45±0.1	1.35±0.1	0.30±0.05

12-3. Tearing Off Force

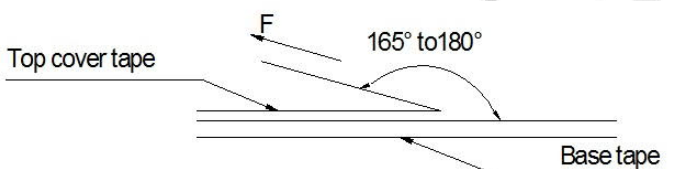

The force for tearing off cover tape is 15 to 80 grams in the arrow direction under the following conditions.

Room Temp. (°C)	Room Humidity (%)	Room atm (hPa)	Tearing Speed mm/min
5~35	45~85	860~1060	300

12-4. Packaging Quantity

Chip/Reel
3000