



# MIP Series

## Data Sheet

<b>Product Name</b>	<b>MIP Series</b>
<b>Series</b>	<b>SMD Power Inductor</b>
<b>Size</b>	<b>EIAJ 2012 - 2520</b>
<b>Version</b>	<b>A10</b>

## Multilayer Ferrite Power Inductor (MIP Series)

This product belongs to the 3C and industrial grade standard, not for automotive application. If customer privately uses to automotive parts and results in any consequences, INPAQ is not responsible for after-sales service, thank you!

### ■ Features

- The monolithic construction performs high reliability and ensures a closed magnetic flux in a component avoids magnetic leakage and interference .
- Allow for higher mounting density.
- Low DC resistance.

### ■ Applications

Suitable for DVD , DSC , PND , PC , NB , Power Line

### ■ Shapes and Dimensions

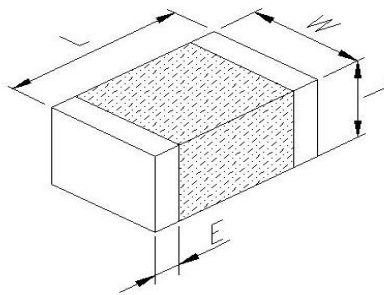

TYPE	2012 (EIA0805)	2016 (EIA0806)	2520 (EIA1008)
<b>L</b>	2.00±0.20	2.00±0.20	2.50±0.20
<b>W</b>	1.25±0.20	1.60±0.20	2.00±0.20
<b>T</b>	0.90±0.10	0.90±0.10	0.90±0.10
<b>E</b>	0.50±0.30	0.50±0.30	0.50±0.30
<b>Unit</b>	mm	mm	mm

■ **Part Number Code**

MIP 2012 2R2 M B E  
1 2 3 4 5 6

- 1 Series Name
- 2 Size Code : The first two digitals: length(mm) , the last two digitals: width(mm)
- 3 Inductance : R = Decimal point , Unit =  $\mu$ H
- 4 Tolerance : M =  $\pm 20\%$
- 5 Soldering : Green Parts , B= Lead-Free for whole chip
- 6 Packaging : E = Embossed plastic tape, 7" reel

■ **Part Number and Characteristics Table**

Part Number.	Inductance $\pm 20\%$ ( $\mu$ H)	Test Freq. (MHz)	SRF (MHz) Min.	DCR $\pm 25\%$ ( $\Omega$ )	Rated Current (mA)
<b>2012 Series</b>					
MIP2012 1R0MBE	1.00	1	90	0.100	1100
MIP2012 2R2MBE	2.20	1	70	0.170	900
MIP2012 3R3MBE	3.30	1	50	0.200	800
MIP2012 4R7MBE	4.70	1	40	0.230	700
<b>2016 Series</b>					
MIP2016 2R2MBE	2.20	1	40	0.120	1100
MIP2016 4R7MBE	4.70	1	20	0.160	900
<b>2520 Series</b>					
MIP2520 R47MBE	0.47	1	100	0.040	1800
MIP2520 1R0MBE	1.00	1	60	0.055	1600
MIP2520 1R5MBE	1.50	1	50	0.070	1500
MIP2520 2R2MBE	2.20	1	40	0.080	1300
MIP2520 3R3MBE	3.30	1	30	0.100	1200
MIP2520 4R7MBE	4.70	1	25	0.110	1100
MIP2520 6R8MBE	6.80	1	25	0.200	1100
Test Instruments and Conditions	<ul style="list-style-type: none"> <li>• Agilent E4991A/B RF Impedance / Material Analyzer or Equivalent</li> <li>• HP4338A/B Milliohm meter</li> </ul> Test Frequency : 1 MHz / OSC Level : 100mV				

\*1 : For special part number which is not shown in the above table, please refer to appendix.

\*2 : Apply DC 0.4 ~ 0.6A to chip for 1 ~ 3 sec. before to measure inductance.

■ Typical Characteristic

Inductance @ Frequency

2012 Series

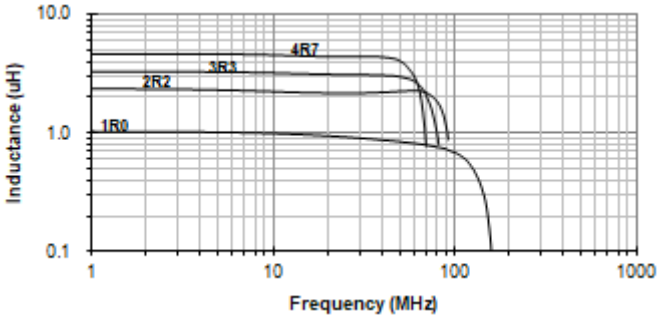

2016 Series

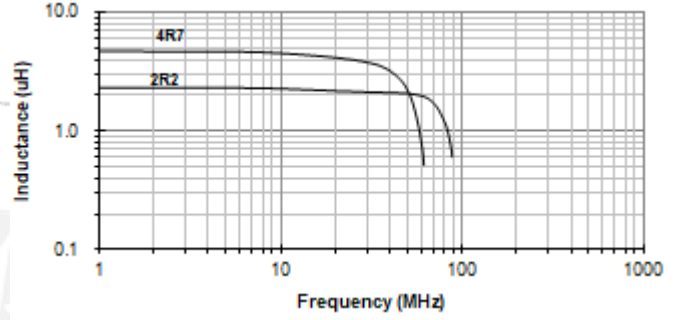

2520 Series

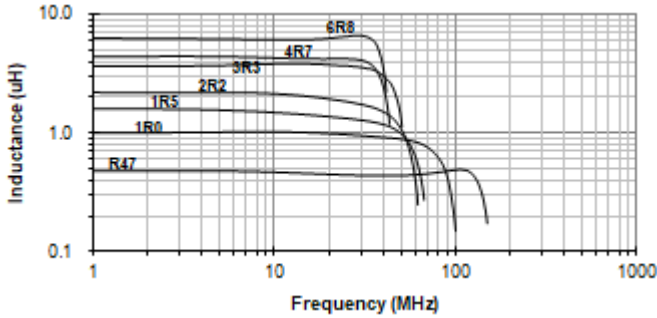

Inductance vs. DC-bias

2012 Series

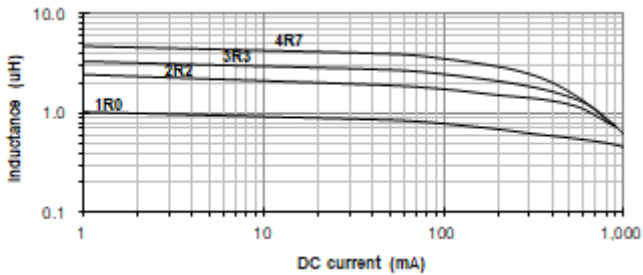

2016 Series

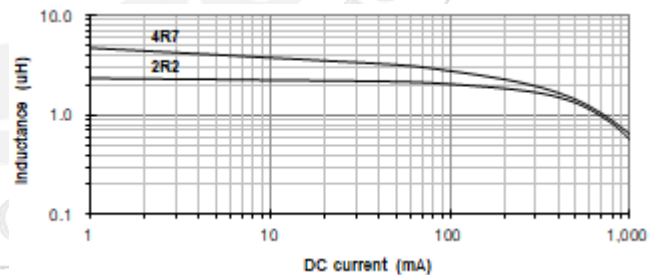

2520 Series

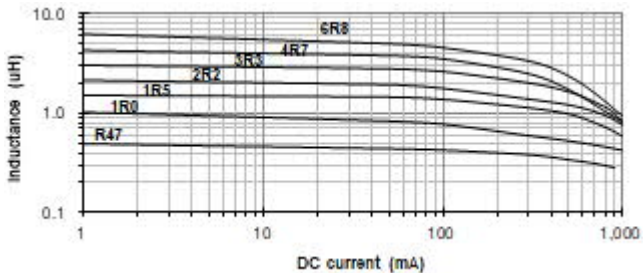

**Temperature rise vs. DC-bias**

**2012 Series**

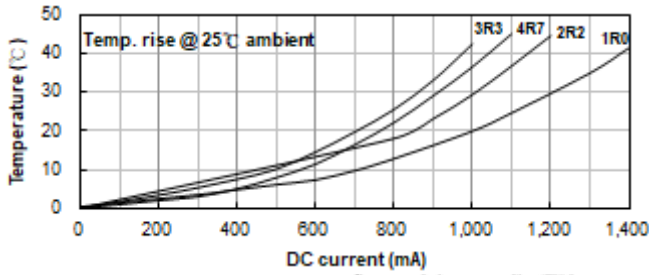

**2016 Series**

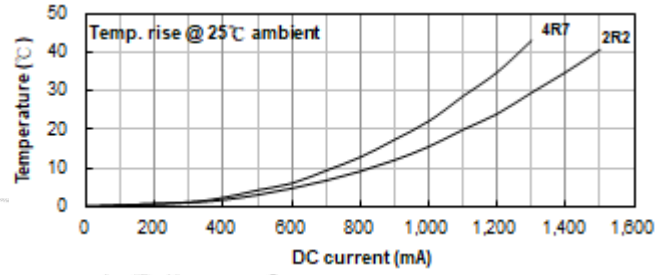

**2520 Series**

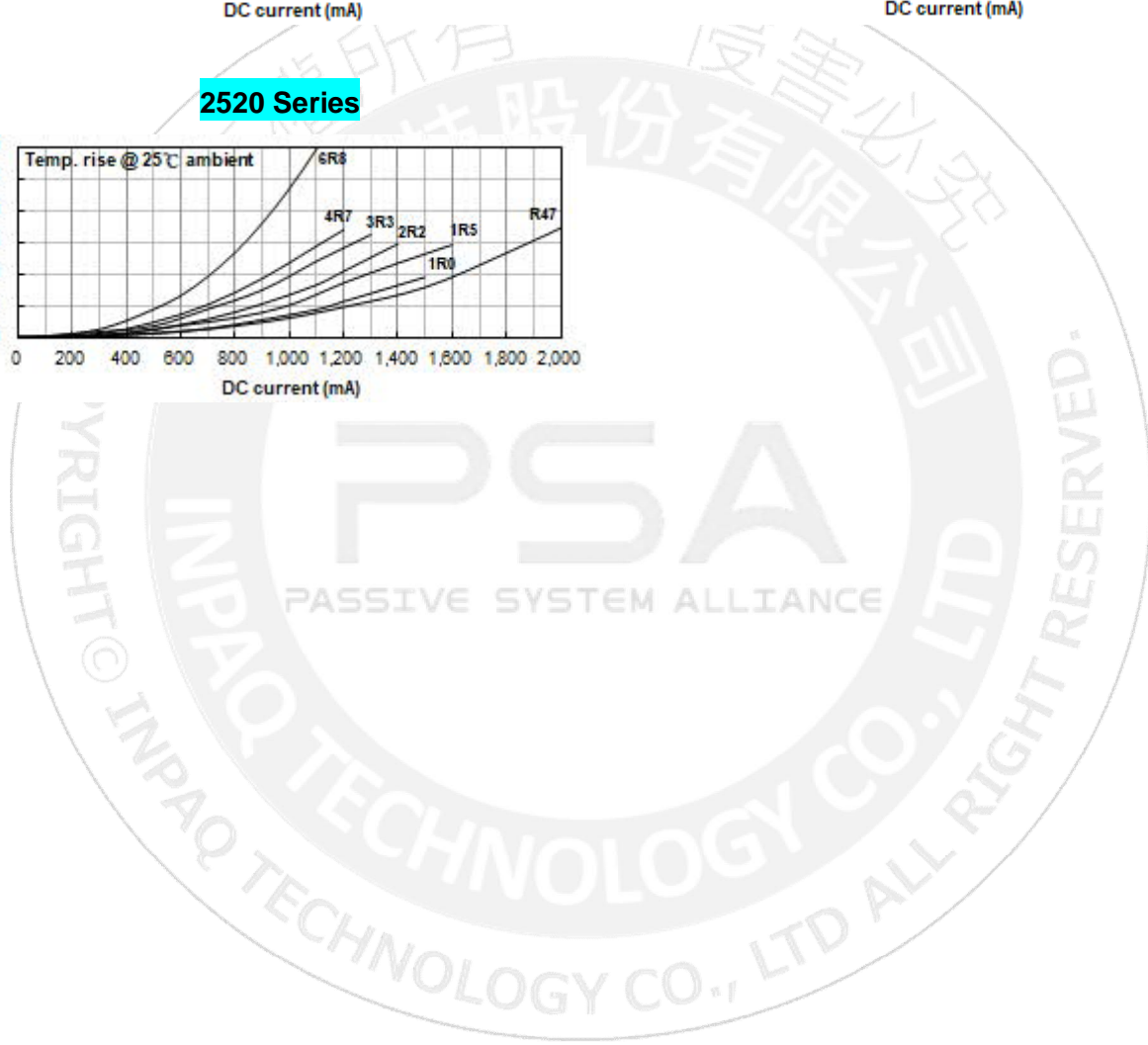
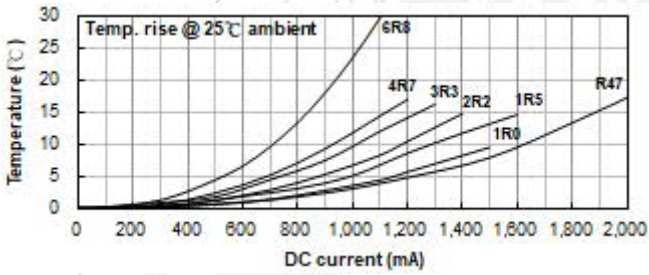

## ■ Tape and Reel Specifications

### Plastic Carrier (E)

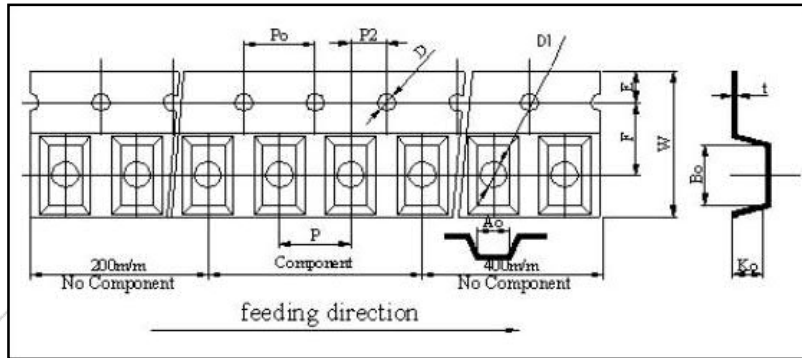

### Taping Dimensions

Unit : mm

Type	2012	2016	2520
Symbol	<b>E</b>	<b>E</b>	<b>E</b>
W	8.00 ± 0.10	8.00 ± 0.10	8.00 ± 0.10
P	4.00 ± 0.10	4.00 ± 0.10	4.00 ± 0.10
E	1.75 ± 0.10	1.75 ± 0.10	1.75 ± 0.10
F	3.50 ± 0.10	3.50 ± 0.10	3.50 ± 0.10
D	1.55 ± 0.05	1.55 ± 0.05	1.55 ± 0.05
D1	1.00 ± 0.05	1.00 ± 0.05	1.00 ± 0.05
Po	4.00 ± 0.10	4.00 ± 0.10	4.00 ± 0.10
10Po	40.0 ± 0.20	40.0 ± 0.20	40.0 ± 0.20
P2	2.00 ± 0.10	2.00 ± 0.10	2.00 ± 0.10
Ao	1.40 ± 0.10	1.80 ± 0.10	2.25 ± 0.10
Bo	2.30 ± 0.10	2.20 ± 0.10	2.80 ± 0.10
Ko(T)	1.13 ± 0.10	1.15 ± 0.10	1.35 ± 0.10
t	0.22 ± 0.05	0.22 ± 0.05	0.22 ± 0.05

■ Reel Dimensions

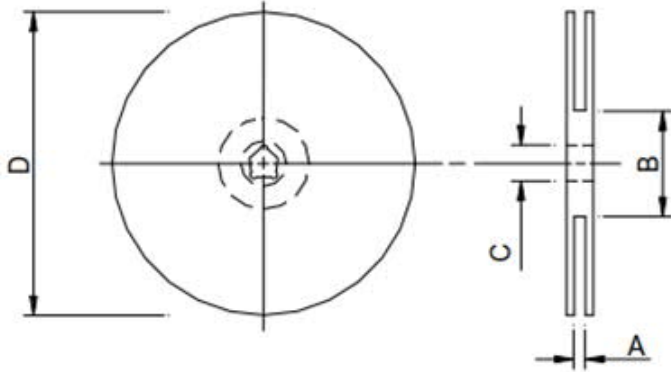

Type	7"
A(mm)	10±1.5
B(mm)	50 or more
C(mm)	13.2±1.0
D(mm)	178±2.0

7" Reel Packaging Quantity			
PART SIZE (EIA SIZE)	2012 (0805)	2016 (0806)	2520 (1008)
Qty.(pcs)	3,000	3,000	3,000
BOX	5 reels / inner box	5 reels / inner box	5 reels / inner box

■ Recommended Soldering Conditions

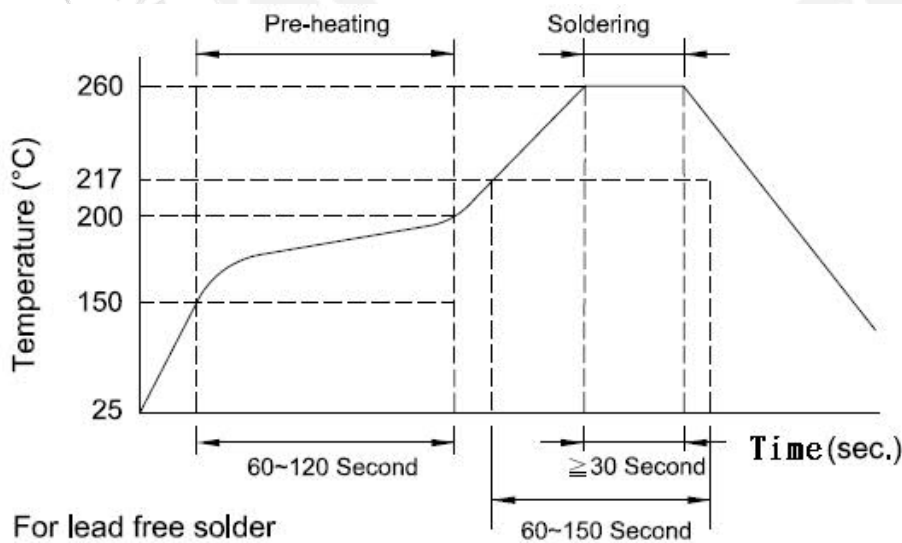

■ Land Patterns for Reflow Soldering

Solder land information :

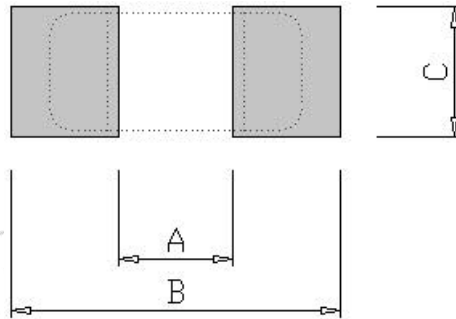

Size(mm)	A	B	C
2012	1.0 ~ 1.2	3.0 ~ 4.0	0.8 ~ 1.1
2016	1.0 ~ 1.2	3.0 ~ 4.0	1.0 ~ 1.5
2520	1.2 ~ 1.5	3.5 ~ 4.0	1.5 ~ 2.0

■ Reliability and Test Condition

Test item	Test condition	Criteria
<b>Resistance to Solder Heat</b>	<ol style="list-style-type: none"> <li>Solder temperature : <math>260 \pm 5^{\circ}\text{C}</math></li> <li>Flux : Rosin</li> <li>DIP time : <math>10 \pm 1</math> sec</li> </ol>	<ol style="list-style-type: none"> <li>More than 95 % of terminal electrode should be covered with new solder</li> <li>No mechanical damage</li> <li>Inductance value should be within <math>\pm 20</math> % of the initial value</li> </ol> <p>* Apply DC 0.4 ~ 0.6A to chip for 1 ~ 3 sec. before to measure inductance.</p>
<b>Solderability</b>	<ol style="list-style-type: none"> <li>Solder temperature : <math>235 \pm 5^{\circ}\text{C}</math></li> <li>Flux : Rosin</li> <li>DIP time : <math>5 \pm 1</math> sec</li> </ol>	<ol style="list-style-type: none"> <li>More than 95 % of terminal electrode should be covered with new solder</li> <li>No mechanical damage</li> </ol>

Test item	Test condition	Criteria
<b>Adhesive Test</b>	<ol style="list-style-type: none"> <li>1. Reflow temperature : 245°C It shall be Soldered on the substrate applying direction parallel to the substrate</li> <li>2. Apply force(F) : 5 N</li> <li>3. Test time : 10 sec</li> </ol>	<ol style="list-style-type: none"> <li>1. No mechanical damage</li> <li>2. Soldering the products on PCB after the pulling test force &gt; 5 N</li> </ol>
<b>Thermal Shock</b>	<ol style="list-style-type: none"> <li>1. Temperature:-40 ~ +85°C For 30 minutes each</li> <li>2. Cycle: 100 cycles</li> <li>3. Measurement: at ambient temperature 24 hours after test completion</li> </ol>	<ol style="list-style-type: none"> <li>1. No mechanical damage</li> <li>2. Inductance should be within <math>\pm 20\%</math> of the initial value</li> </ol> <p>* Apply DC 0.4 ~ 0.6A to chip for 1 ~ 3 sec. before to measure inductance.</p>
<b>High Temperature Resistance</b>	<ol style="list-style-type: none"> <li>1. Temperature: 85 <math>\pm</math> 5°C</li> <li>2. Testing time: 1000 hrs</li> <li>3. Measurement: at ambient temperature 24 hours after test completion</li> </ol>	<ol style="list-style-type: none"> <li>1. No mechanical damage</li> <li>2. Inductance should be within <math>\pm 20\%</math> of the initial value</li> </ol> <p>* Apply DC 0.4 ~ 0.6A to chip for 1 ~ 3 sec. before to measure inductance.</p>
<b>Humidity</b>	<ol style="list-style-type: none"> <li>1. Temperature: 40°C <math>\pm</math> 2°C</li> <li>2. Humidity: 90-95 % RH</li> <li>3. Testing time: 1000 hrs</li> <li>4. Measurement: at ambient temperature 24 hours after test completion</li> </ol>	<ol style="list-style-type: none"> <li>1. No mechanical damage</li> <li>2. Inductance should be within <math>\pm 20\%</math> of the initial value</li> </ol> <p>* Apply DC 0.4 ~ 0.6A to chip for 1 ~ 3 sec. before to measure inductance.</p>
<b>Rated Current</b>	<p>At ambient temperature &amp; humidity</p> <p>Testing time:5 minutes</p> <p>( under full rated current )</p>	<p>MIP product surface temp : below room temperature plus 40°C</p>

## ■ General Technical Data

Operating temperature range : - 40°C ~ +85°C

Storage Condition : Less than 40°C and 70% RH

Storage Time : 12 months Max.

Soldering method : Reflow