

SPECIFICATION FOR APPROVAL

CUSTOMER : MT System

CUSTOMER P/N : ZEMCT131

SME P/N : MCT18H-04X

EDITION : A.0

DATE : 2022-10-25

DRAWING		
MADE	CHECK	APPROVAL
Liu Hen	Li Shuo	Peng Bin

CUSTOMER APPROVE

SHANGHAI MEISONGBEI ELECTRONICS CO.,LTD

Add: No.3891 Jinxiu Road, Pudong New District, Shanghai, China

Tel:+86-21-62883517 Fax:+86-21-62883519

Http://www.meisongbei.com

E-mail:sales@meisongbei.com

SPECIFICATION FOR APPROVAL

Customer: MT System
 Customer P/N: ZEEMCT131
 SME P/N: MCT18H-04X
 Date: 2022-10-25



A Dimension:Unit(mm)

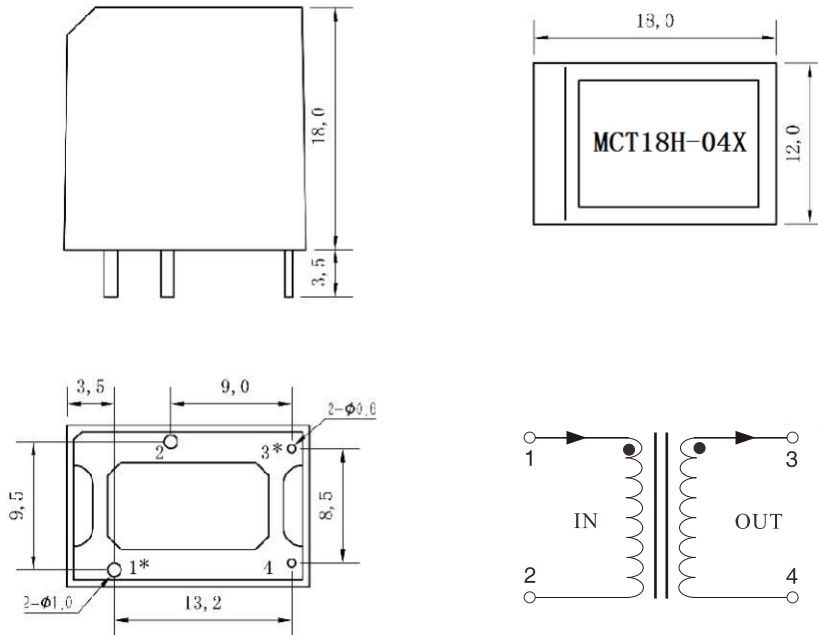

B Electrical Specifications:

Working environment	Working Temperature	-40°C~+85°C	storage temperature	-40°C~+85°C
	humidity	<=90%	Pressure condition	normal pressure
Electrical Characteristics	Rated Current	5A	Secondary Current	2.5mA
	Turns ratio	2000:1	Rated Frequency	50/60Hz
	Linearity	≤0.2%	Phase angle error	≤20'
	Insulation Resistance	100MΩ min	Electrical Strength	3000Vrms/1mA/60S (50Hz/60S)
Mechanical Parameters	Outer case	PBT	Potting	epoxy resin

Made	Liu Hen	Checked	Li shuo	Approved	Wang Bin
------	---------	---------	---------	----------	----------

Shanghai Meisongbei Electronics Co.,Ltd.

Add: No.3891 Jinxiu Road, Pudong New District, Shanghai, China Tel:+86-21-62883517 Fax:+86-21-62883519
 Http://www.meisongbei.com