



BONREX

REV.	ECN NO.	REVISED	DATE

NOTE:

1.MATERIAL:

a.HOUSING:PA66 UL94V-0

b.CONTACT:BRASS

(SURFACE PLATING: Ni100u"-120u")

SEE ORDERING INFORMATION

2.ELECTRIC:

a.CONTACT RESISTANCE: 30 MILLIOHMS MAX

b.INSULATION RESISTANCE: 1000 MEGA OHMS MIN

c.DIELECTRIC VOLTAGE: 500V AC ONE SEC LEVEL

d.OPERATING TEMPERATURE: -25° C~ +85° C

ORDERING INFORMATION

BS-04-A***004

电池座系列

BS-04系列

DIP 90° TYPE

PLATING:

A-Au1U"

J-Ni100U"~120U"

K-Sn100U"~120U"

MATERIAL:

1A-PBT BLACK

1B-PA66 BLACK

2A-PPA BROWN

2B-PPA BLACK

3A-PPS BROWN

3B-PPS BLACK

4A-LCP WHITE

4B-LCP BLACK

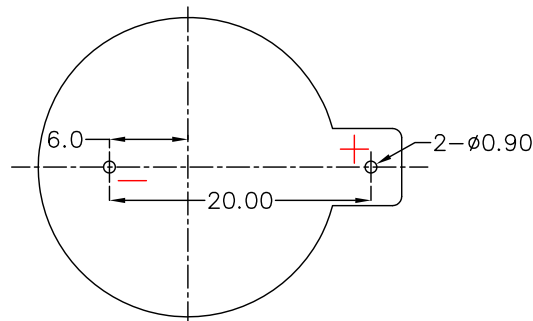
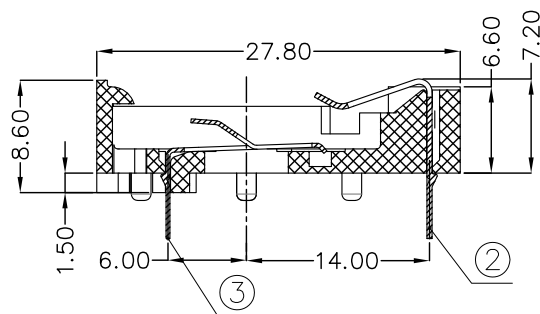
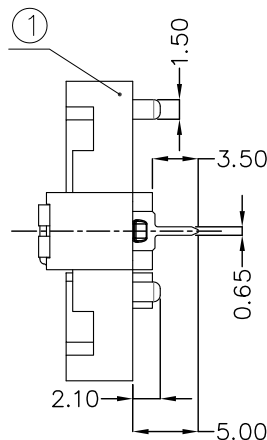
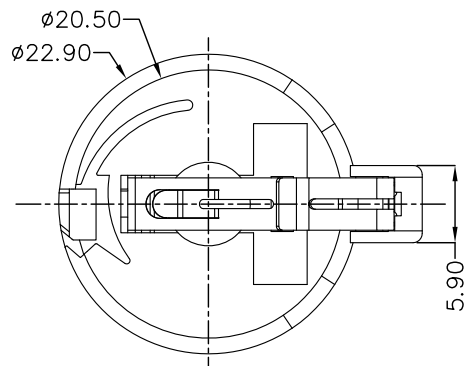

PCB Layout Diagram
Top View

工程部
2018-10-10
LQ. HUANG

3	TERMINAL(-)	1	BRASS T=0.3MM	Ni-Plating
2	TERMINAL(+)	1	BRASS T=0.4MM	Ni-Plating
1	HOUSING	1	PA66 UL94V-0	BLACK
NO.	PART NAME	Q'TY	MATERIAL	PLATING & COLOR

UNLESS OTHERWISE SPECIFIED TOLERANCES							
DECIMALS:	ANGLES:	DSND	YangFeng	DATE	2018-05-08	TITLE:	
X :±0.30	X :±1°	CHKD	ZhouRuicai	DATE	2018-05-08	BS-2032-4-1 Ni DIP	
X.X :±0.25	X.X :±0.5°	APVD	XueShunyong	DATE	2018-05-08	PART NO.:	
X.XX :±0.20		WEIGHT:		SCALE:	SIZE: A4	VIEW:	BH810 Ni-Plating
X.XXX :±0.10		SHEET 1 OF 1		UNIT: mm	REV.: A/0	OBJECT: MY	DRAW NO.:MY-CP-0142