

SWD024

PN: SZ21617IB66



Features:

- Frequency bands from 824~960MHz, 1710~2690MHz.
- SMD Compliant.
- Impedance 50 Ohm.
- Antenna for 4G / 3G/ 2G applications including MIMO systems.

Applications:

- Application of 4G/3G/2G equipment.
- LTE ,NB-Iot, Cat M1.
- Portable Devices.
- Remote monitoring.
- Network Devices.
- Wearable devices.
- Smart Metering.
- Payment Terminals.

1. Electrical Specifications

| Standards | 4G&3G&2G | | |
|-------------------------------|------------------|-----------|-----------|
| Frequency range (MHz) | 824~960 | 1710~2170 | 2300~2690 |
| Peak Gain (dBi) | -4.3~-0.5 | -4.9~0.3 | -4.1~2.5 |
| Average Gain (dB) | -7.9~-5.2 | -8.0~-5.3 | -9.9~-3.9 |
| VSWR | < 5.6 | < 5.8 | < 5.0 |
| Return Loss(dB) | < -3.1 | < -2.9 | < -3.4 |
| Efficiency (%) | 16~30 | 16~30 | 10~40 |
| Polarization mode | Linear | | |
| Radiation pattern | Omni-Directional | | |
| Output impedance (Ω) | 50 | | |
| Max. Input Power(W) | 5 | | |

Note:

All parameters are measured with Sunnyway's EVK which size is 150*40mm

2. Mechanical and Environmental Specification

| | |
|----------------------------|-----------------------------|
| Mounting Type | SMD |
| Antenna size(mm) | 23.0 (L) x3.5 (W) x 1.6 (H) |
| Material | PCB |
| Operating Temperature (°C) | - 40 °C ~ + 85 °C |
| Storage Temperature(°C) | - 40 °C ~ + 85 °C |

3. Antenna parameters

5G&4G&3G&2G(Board length 150mm)

3.1 General Data

| | | | | | | |
|-------------------|------|------|------|-------|------|------|
| FRE (MHz) | 824 | 960 | 1710 | 2170 | 2300 | 2690 |
| VSWR | 2.2 | 5.4 | 2.4 | 1.2 | 2.6 | 2.2 |
| Return Loss | -8.7 | -3.3 | -7.6 | -23.4 | -7.1 | -8.5 |
| Eff (%) | 16.0 | 18.6 | 29.7 | 21.0 | 34.3 | 10.3 |
| Average Gain (dB) | -7.9 | -7.3 | -5.3 | -6.8 | -4.7 | -9.9 |

3.2 VSWR

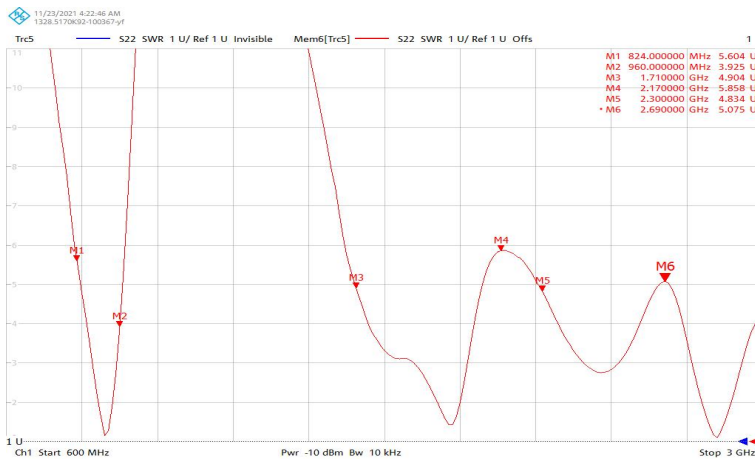

3.3 Return Loss

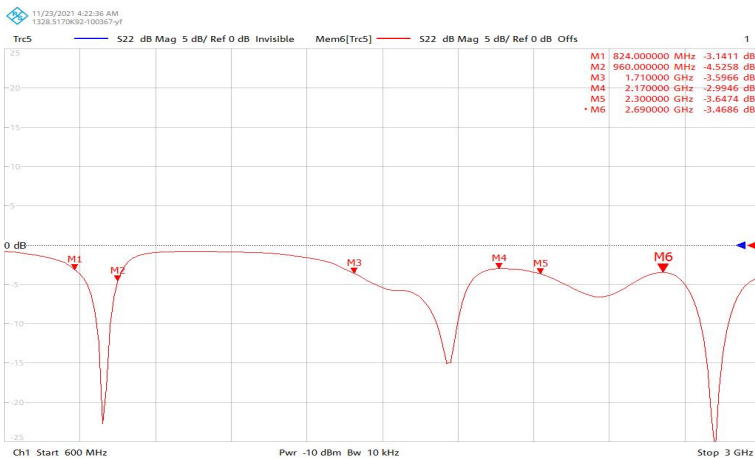

3.4 Efficiency

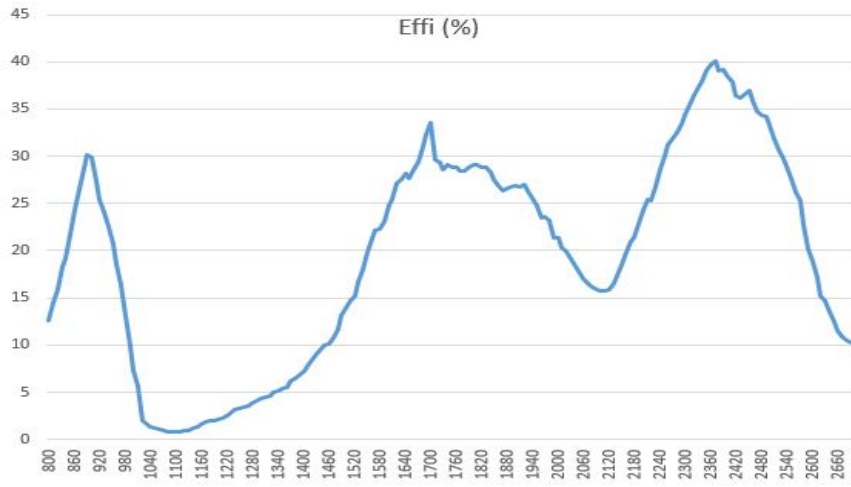

3.5 Gain



3.6 Directional pattern

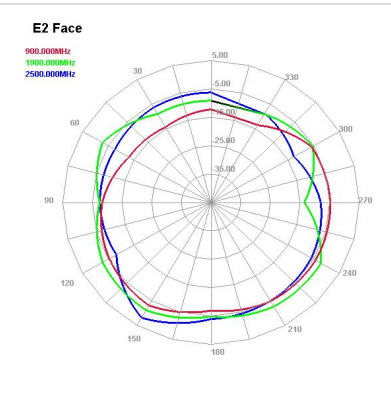
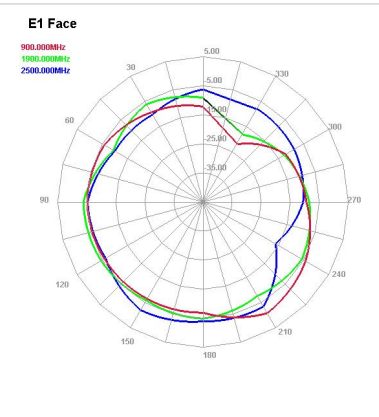
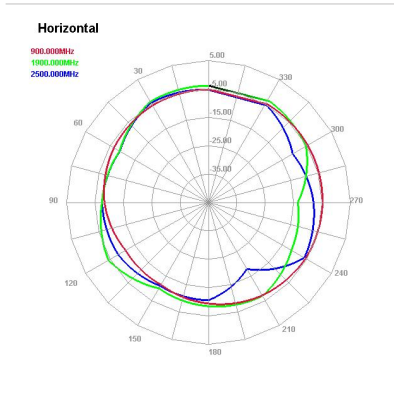
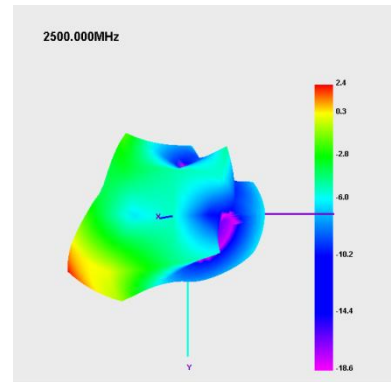
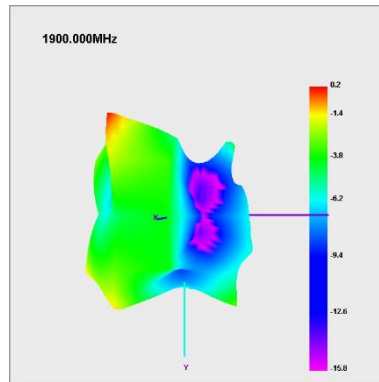
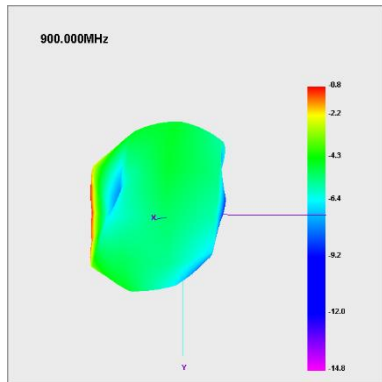
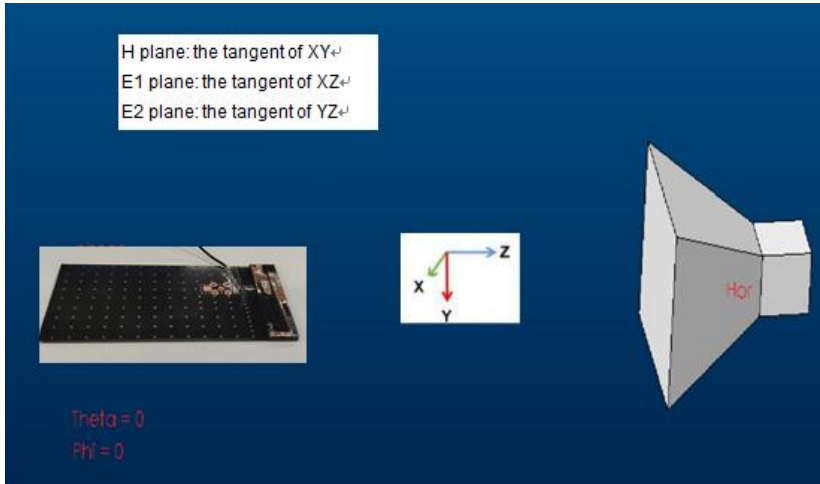

4. Transmission Line

The characteristic impedance of all transmission lines shall be designed as 50 Ω .

- The length of the transmission lines should be kept to as short as possible.
- Any other part of the RF system, such as transceiver, power amplifiers, etc., shall also be designed with an impedance of 50 Ω .

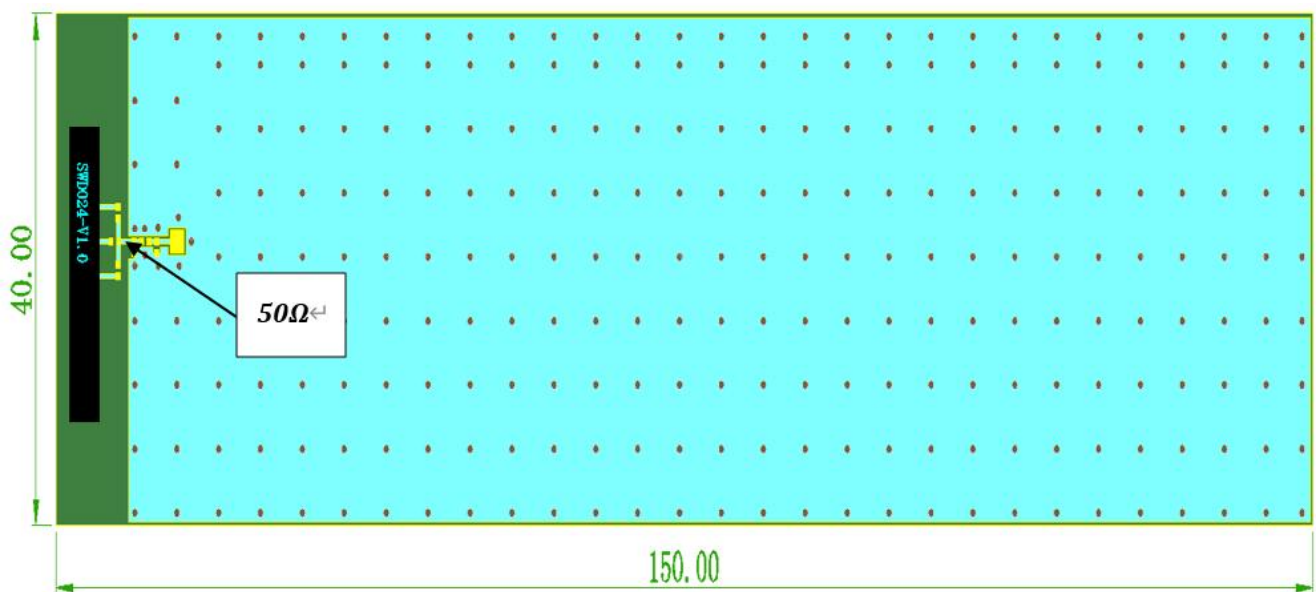

5. Schematic symbol and Pin definition

The pin assignment for the SWD024 antenna are as follows. The antenna has 5 pins and only three work. The other pins are designed for mechanical strength.

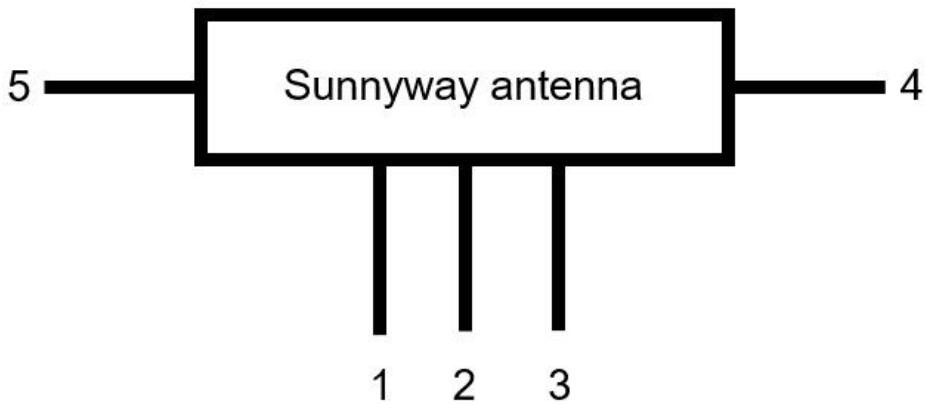

| Pin No. | Description |
|---------|-------------------------------|
| 1/2/3 | Feed |
| 4/5 | Not used (Mechanical only) |

6. Matching circuit

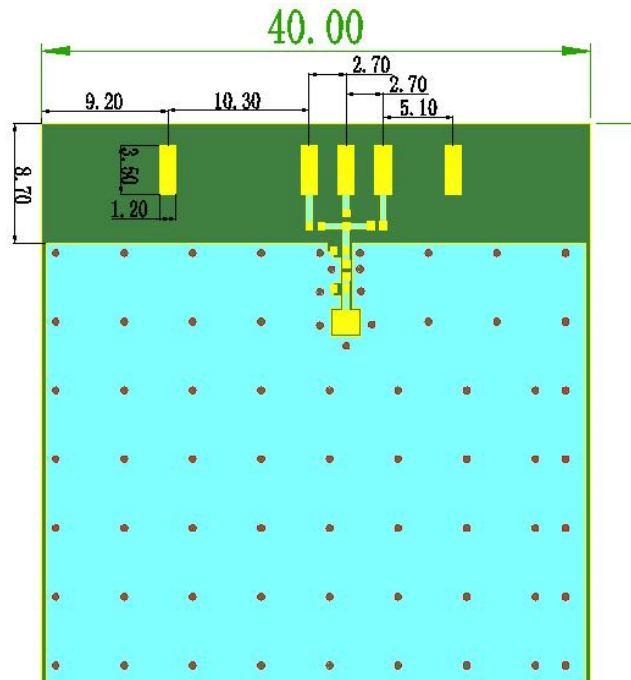

The antenna requires a matching circuit that must be optimized for each product. The matching circuit will require up to six components and the following circuit should be designed into the host PCB. Not all components may be required but should be included as a precaution. The matching network must be placed close to the antenna feed to ensure it is more effective in tuning the antenna.

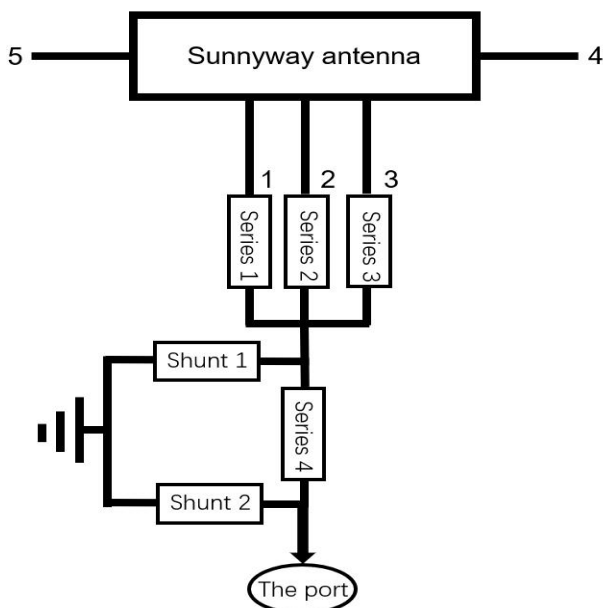

| Pin No. | Type | Value |
|----------|----------|-------|
| Series 1 | Inductor | 22nH |
| Series 2 | Inductor | 2.2nH |
| Series 3 | Inductor | 4.3Nh |
| Shunt 1 | Inductor | 18nH |
| Series 4 | Inductor | 1.5nH |
| Shunt 2 | N/A | N/A |

7. Host PCB Size

The performance of the low frequency section depends on the length of the ground plane. Reducing GND length will directly impact on the performance of low frequency band.

Take antenna efficiency measurement results on different GND sizes as an example:

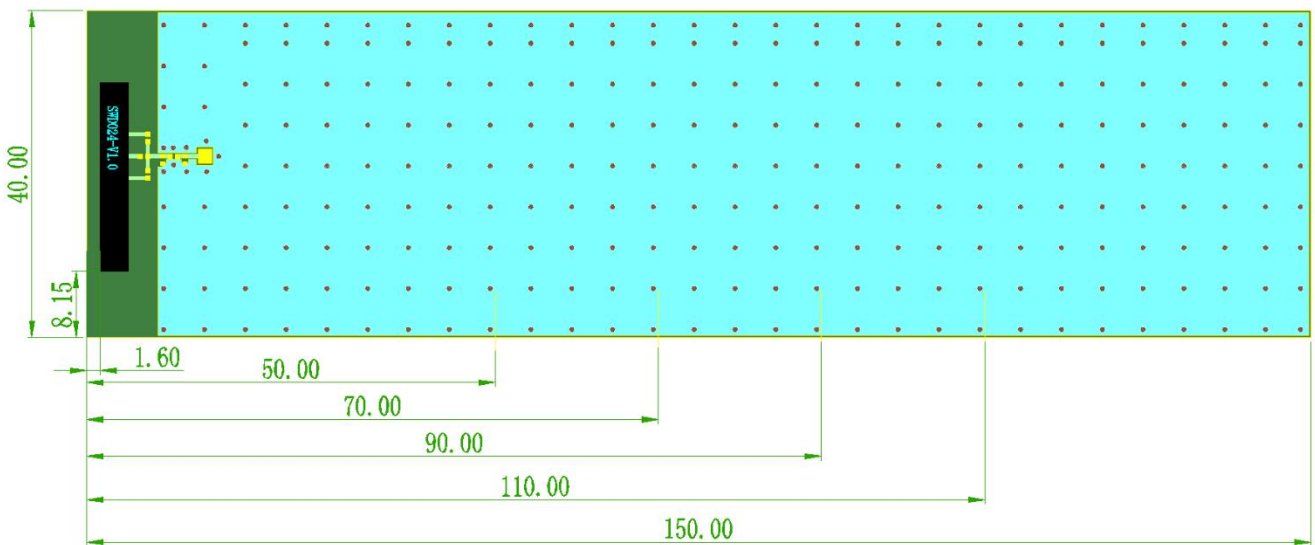

Passive Efficiency vs. PCB length

All results measured in Sunnyway's anechoic chamber

7.1 Board length 110mm

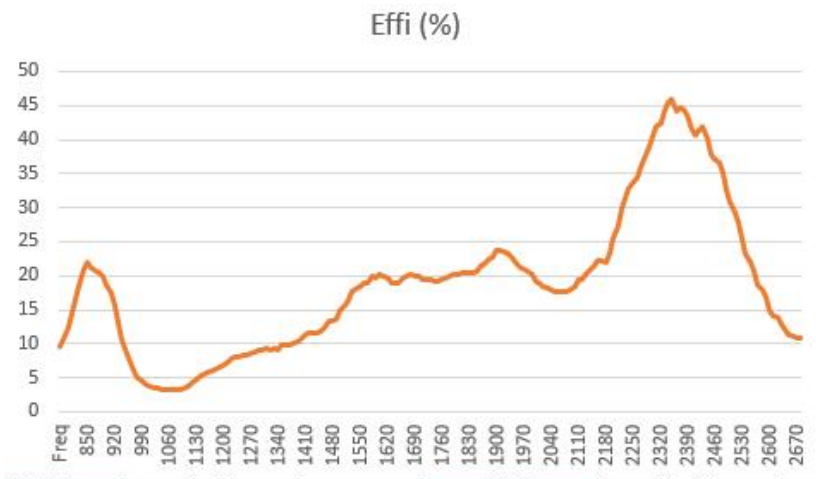

7.2 Board length 90mm

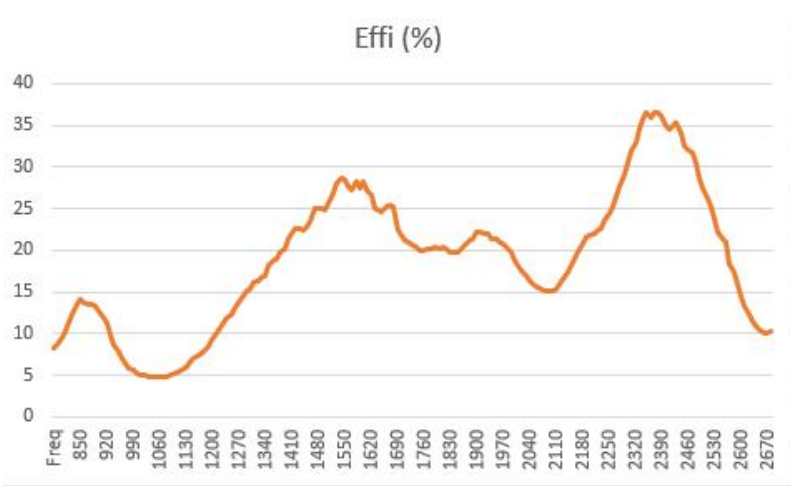

7.3 Board length 70mm

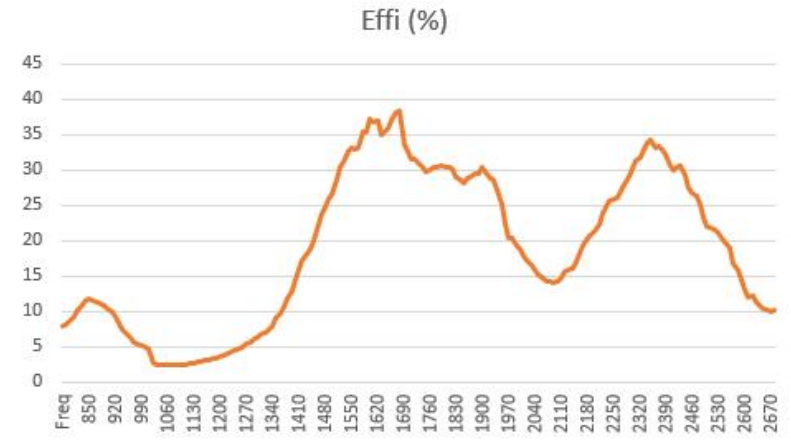

7.4 Board length 50mm



8. Antenna Drawings

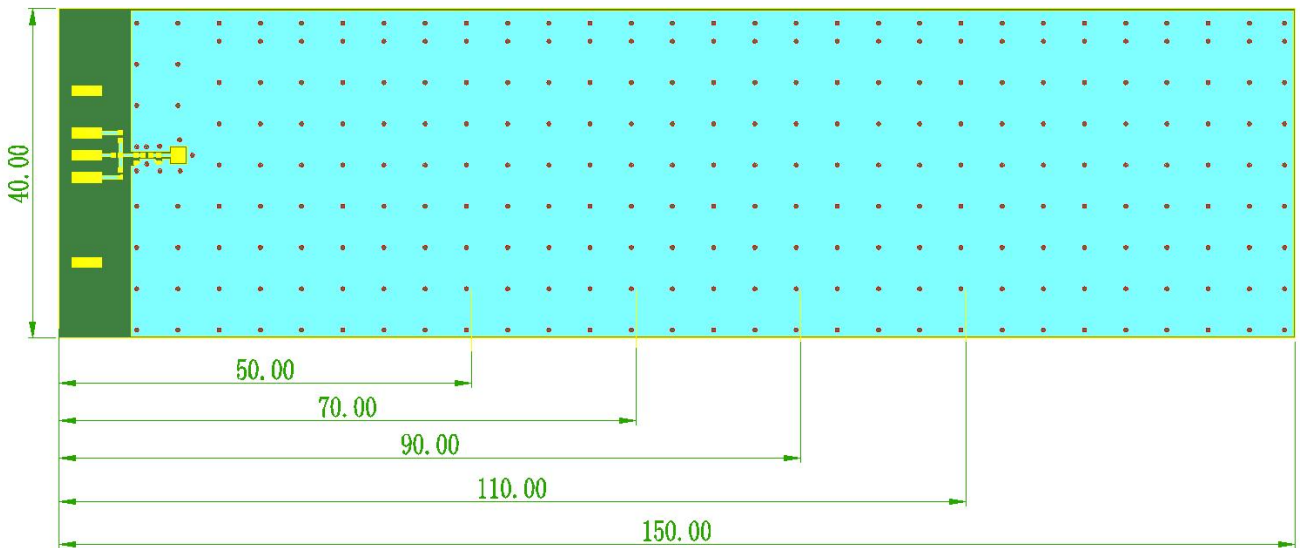
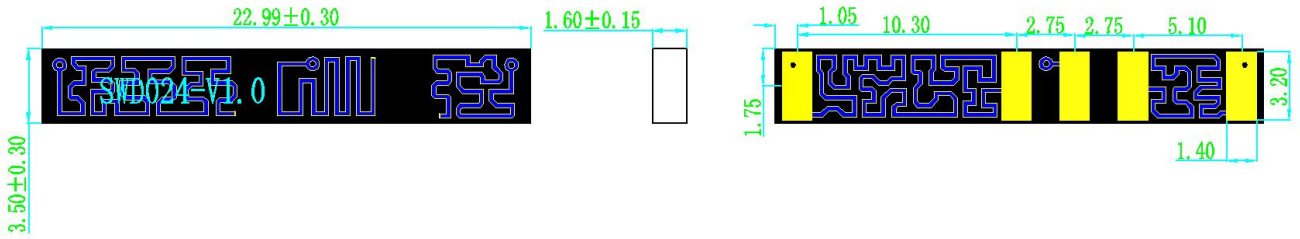

9. Soldering Temperature

| PHASE | PROFILE FEATURES | PB-Free Assembly(max.) |
|-----------|-------------------------------|------------------------|
| RAMP-UP | Avg.Ramp-up Rate(Tsmax to Tp) | 3°C/second(max.) |
| PREHEAT | Temperature Min(Tsmin) | 150°C |
| | Temperature Max(Tsmax) | 180°C |
| | Time(tsmin to tsmax) | 120seconds max |
| REFLOW | Temperature(TL) | 210°C |
| | Total Time above TL(tl) | 50seconds max |
| PEAK | Temperature(Tp) | 260°C |
| | Time(tp) | 10seconds max |
| RAMP-DOWN | Rate | 5°C/second max |

10. Reflow Profile

