

FEATURES

- Operates with a single 3.3V supply
- Compatible with ISO 11898-2 standard
- Bus pin ESD protection exceeds $\pm 16\text{kV}$ HBM
- High input impedance allows for up to 120 nodes
- Adjustable driver transition times for improved emissions performance
- Low current standby mode: $370\mu\text{A}$ typical
- Very low current sleep mode: 50nA typical
- Designed for data rates up to 1Mbps
- Thermal shutdown protection
- Open circuit fail-safe design
- Glitch free power up and power down protection for hot plugging applications

PRODUCT APPEARANCE



Provide green and environmentally friendly lead-free package

DESCRIPTION

The SIT65HVD234 is the interface between the Controller Area Network (CAN) protocol controller and the physical bus. It is designed for use with the 3.3V μPs , MCUs and DSPs with CAN controllers, or with equivalent protocol controller devices. It is used in industrial automation, control, sensors and drive systems, motor and robotic control, building and climate control (HVAC), telecom and base station control and status. The devices are intended for use in applications employing the CAN serial communication physical layer in accordance with the ISO 11898 standard.

PARAMETER	SYMBOL	CONDITION	MIN.	MAX.	UNIT
Supply voltage	V_{cc}		3	3.6	V
Maximum transmission rate	$1/t_{\text{bit}}$	Non-return to zero code	1		Mbaud
CANH, CANL input or output voltage	V_{can}		-36	+36	V
Bus differential voltage	V_{diff}		1.5	3.0	V
Virtual junction temperature	T_j		-40	125	$^{\circ}\text{C}$

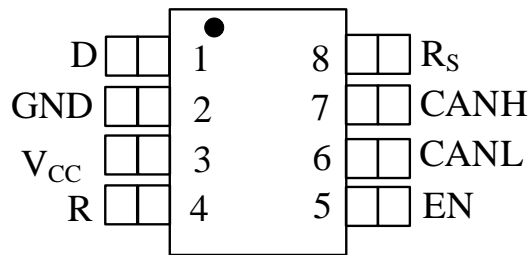
PIN CONFIGURATION

PINNING

PIN	SYMBOL	DESCRIPTION
1	D	CAN transmit data input (LOW for dominant and HIGH for recessive bus states), also called TXD, driver input.
2	GND	Ground.
3	VCC	Transceiver 3.3V supply voltage.
4	R	CAN receive data output (LOW for dominant and HIGH for recessive bus states), also called RXD, receiver output.
5	EN	Enable input pin: EN=1, normal operation (high speed or standby mode); EN=0, low power sleep mode.
6	CANL	Low level CAN bus line.
7	CANH	High level CAN bus line.
8	RS	Mode select pin: strong pull down to GND=high speed mode, strong pull up to VCC=low power mode, 10kΩ to 100kΩ pull down to GND=slope control mode.

LIMITING VALUES

PARAMETER	SYMBOL	VALUE	UNIT
Supply voltage	V _{CC}	-0.3~+6	V
DC voltage on D/R pins	D, R	-0.5~V _{CC} +0.5	V
Voltage range at any bus terminal (CANH, CANL)	CANL, CANH	-36~36	V
Transient voltage on pins CANH, CANL (test with 100Ω) See Fig 10	V _{tr}	-40~+40	V
Receiver output current	I _O	-11~11	mA
Storage temperature	T _{stg}	-40~150	°C
Virtual junction temperature	T _j	-40~125	°C
Welding temperature range		300	°C

The maximum limit parameters mean that exceeding these values may cause irreversible damage to the device. Under these conditions, it is not conducive to the normal operation of the device. The continuous operation of the device at the maximum allowable rating may affect the reliability of the device. The reference point for all voltages is ground.

DRIVER ELECTRICAL DC CHARACTERISTICS

SYMBOL	PARAMETER		CONDITION	MIN.	TYP.	MAX.	UNIT
$V_{O(D)}$	output voltage (Dominant)	CANH	$V_I=0V, R_S=0V, R_L=60\Omega$ (Fig1, Fig 2)	2.45		VCC	V
		CANL		0.5		1.25	
$V_{OD(D)}$	Differential output voltage (Dominant)		$V_I=0V, R_S=0V, R_L=60\Omega$ (Fig 1)	1.5	2	3	V
			$V_I=0V, R_L=60\Omega, R_S=0V$ (Fig 3)	1.2	2	3	V
$V_{O(R)}$	output voltage (Recessive)	CANH	$V_I=3V, R_S=0V, R_L=60\Omega$ (Fig 1)		2.3		V
		CANL			2.3		
$V_{OD(R)}$	Differential output voltage (Recessive)		$V_I=3V, R_S=0V$	-0.12		0.012	V
			$V_I=3V, R_S=0V,$ NO LOAD	-0.5		0.05	V
I_{IH}	High-level input current		$V_I=2V$	-30		30	μA
I_{IL}	Low-level input current		$V_I=0.8V$	-30		30	μA
I_{OS}	Short-circuit output current		CANH=-7V	-250			mA
			CANH=12V			1	
			CANL=-7V	-1			
			CANL=12V			250	
C_O	Output capacitance		See receiver				
I_{CC}	Supply current		Sleep		0.05	2	μA
			Standby		370	600	μA
			$V_I=0V$ (Dominant), No load			6	mA
			$V_I=V_{CC}$ (Recessive), No load			6	mA

(If not otherwise specified, $V_{CC}=3.3V\pm 10\%$, $Temp=T_{MIN}\sim T_{MAX}$, Typical: $V_{CC}=+3.3V$, $Temp=25^\circ C$)

DRIVER SWITCHING CHARACTERISTICS

SYMBOL	PARAMETER	CONDITION	MIN.	TYP.	MAX.	UNIT
t_{PLH}	Propagation delay time (low-to-high-level)	$R=0$, Short circuit (Fig 4)		35	85	ns
		$R=10k\Omega$		70	125	
		$R=100k\Omega$		500	870	

SYMBOL	PARAMETER	CONDITION	MIN.	TYP.	MAX.	UNIT
t_{PHL}	Propagation delay time (high-to-low-level)	R=0, Short circuit (Fig 4)		70	120	ns
		R=10kΩ		130	180	
		R=100kΩ		870	1200	
t_{sk(p)}	Pulse skew (t _{PLH} - t _{PHL})	R=0, Short circuit (Fig 4)		35		ns
		R=10kΩ		60		
		R=100kΩ		370		
t_r	Differential output signal rise time	R=0, Short circuit (Fig 4)	20		70	ns
		R=10kΩ	30		150	
		R=100kΩ	350		1400	
t_r	Differential output signal fall time	R=0, Short circuit (Fig 4)	20		70	ns
		R=10kΩ	30		150	
		R=100kΩ	350		1400	

(If not otherwise specified, V_{CC}=3.3V±10%, Temp=T_{MIN}~T_{MAX}, Typical: V_{CC}=+3.3V, Temp=25°C)

RECEIVER ELECTRICAL CHARACTERISTICS

SYMBOL	PARAMETER	CONDITION	MIN.	TYP.	MAX.	UNIT
V_{IT+}	Positive-going input threshold voltage	Table 1		750	900	mV
V_{IT-}	Negative-going input threshold voltage	Table 1	500	650		mV
V_{hys}	Hysteresis voltage	V _{IT+} - V _{IT-}		100		mV
V_{OH}	High-level output voltage	-6V<V _{ID} <500mV I _O =-8mA (Fig5)	2.4			V
V_{OL}	Low-level output voltage	900mV<V _{ID} <6V I _O =8mA (Fig5)			0.4	V
I_i	Bus input current	V _{IH} =12V, V _{CC} =0V	200		600	μA
I_i		V _{IH} =12V, V _{CC} =3.3V	150		500	μA
I_i		V _{IH} =-7V, V _{CC} =0V	-450		-130	μA
I_i		V _{IH} =-7V, V _{CC} =3.3V	-610		-150	μA
R_i	Bus input resistance	Corresponding standards of ISO 11898-2	20	35	50	kΩ

SYMBOL	PARAMETER	CONDITION	MIN.	TYP.	MAX.	UNIT
R_{diff}	Differential input resistance	Corresponding standards of ISO 11898-2	40		100	k Ω
C_i	Bus input capacitance	Corresponding standards of ISO 11898-2		40		pF
C_{diff}	Differential input capacitance	Corresponding standards of ISO 11898-2		20		pF

(If not otherwise specified, $V_{CC}=3.3V\pm 10\%$, $Temp=T_{MIN}\sim T_{MAX}$, Typical: $V_{CC}=+3.3V$, $Temp=25^{\circ}C$)

RECEIVER SWITCHING CHARACTERISTICS

SYMBOL	PARAMETER	CONDITION	MIN.	TYP.	MAX.	UNIT
t_{PLH}	Propagation delay time (low-to-high-level)	Fig 6		35	60	ns
t_{PHL}	Propagation delay time (high-to-low-level)	Fig 6		35	60	ns
t_{sk}	Pulse skew	$ t_{PHL} - t_{PLH} $		7		ns
t_r	Output signal rise time	Fig 6		2	5	ns
t_f	Output signal fall time	Fig 6		2	5	ns

(If not otherwise specified, $V_{CC}=3.3V\pm 10\%$, $Temp=T_{MIN}\sim T_{MAX}$, Typical: $V_{CC}=+3.3V$, $Temp=25^{\circ}C$)

DEVICE SWITCHING CHARACTERISTICS

SYMBOL	PARAMETER	CONDITION	MIN.	TYP.	MAX.	UNIT
$t_{(LOOP1)}$	Total loop delay, driver input to receiver output, recessive to dominant	R=0, Short circuit (Fig 9)		70	135	ns
		R=10 k Ω		105	190	
		R=100 k Ω		535	1000	
$t_{(LOOP2)}$	Total loop delay, driver input to receiver output, dominant to recessive	R=0, Short circuit (Fig 9)		70	165	ns
		R=10 k Ω		105	190	
		R=100 k Ω		535	1000	

(If not otherwise specified, $V_{CC}=3.3V\pm 10\%$, $Temp=T_{MIN}\sim T_{MAX}$, Typical: $V_{CC}=+3.3V$, $Temp=25^{\circ}C$)

OVER TEMPERATURE PROTECTION

SYMBOL	PARAMETER	CONDITION	MIN.	TYP.	MAX.	UNIT
$T_{j(sd)}$	Thermal shutdown temperature			155	170	°C

(If not otherwise specified, $V_{CC}=3.3V\pm 10\%$, $Temp=T_{MIN}\sim T_{MAX}$, Typical: $V_{CC}=+3.3V$, $Temp=25^{\circ}C$)

CONTROL-PIN CHARACTERISTICS

SYMBOL	PARAMETER	CONDITION	MIN.	TYP.	MAX.	UNIT
T_{WAKE}	wake-up time from standby mode	R_S adds square wave (Fig7)		0.55	1.5	μs
	wake-up time from sleep mode	EN adds square wave (Fig 8)		1	5	μs
I_{RS}	Input current for high-speed	$V_{RS}<1V$	-450		0	μA
V_{RS}	Input voltage for standby/sleep	$0<V_{RS}<V_{CC}$	$0.75V_{CC}$		V_{CC}	V
I_{off}	Power-off leakage current	$V_{CC}=0V$, $V_{CANH}=V_{CANL}=5V$	-250		250	μA

(If not otherwise specified, $V_{CC}=3.3V\pm 10\%$, $Temp=T_{MIN}\sim T_{MAX}$, Typical: $V_{CC}=+3.3V$, $Temp=25^{\circ}C$)

SUPPLY CURRENT

SYMBOL	PARAMETER	CONDITION	MIN.	TYP.	MAX.	UNIT
I_{CC}	Power consumption in sleep mode	EN=0, $R_S=V_{CC}$ or 0V, $V_I=V_{CC}$		0.05	2	μA
I_{CC}	Power consumption in standby mode	EN= V_{CC} , $R_S=V_{CC}$, $V_I=V_{CC}$		370	600	μA
I_{CC}	Dominant power consumption	EN= V_{CC} , $V_I=0V$, $R_S=0V$, LOAD=60 Ω		50	70	mA
I_{CC}	Recessive power consumption	EN= V_{CC} , $V_I=V_{CC}$, $R_S=0V$, NO LOAD			6	mA

(If not otherwise specified, $V_{CC}=3.3V\pm 10\%$, $Temp=T_{MIN}\sim T_{MAX}$, Typical: $V_{CC}=+3.3V$, $Temp=25^{\circ}C$)

FUNCTION TABLE
Table 1 Receiver characteristics in common mode ($V_{(RS)}=1.2V$)

V_{ID}	V_{CANH}	V_{CANL}	R OUTPUT	
900mV	-6.1V	-7V	L	V_{OL}
900mV	12V	11.1V	L	
6V	-1V	-7V	L	
6V	12V	6V	L	
500mV	-6.5V	-7V	H	V_{OH}
500mV	12V	11.5V	H	
-6V	-7V	-1V	H	
-6V	6V	12V	H	
X	Open	Open	H	

(1) H=High level; L=Low level; X=Irrelevant.

Table2.Driver Function

INPUTS			OUTPUTS		
D	EN	R_s	CANH	CANL	BUS STATE
L	H	$\leq 0.33V_{CC}$	H	L	Dominant
H	X	$\leq 0.33V_{CC}$	Z	Z	Recessive
Open	X	X	Z	Z	Recessive
X	X	$> 0.75V_{CC}$	Z	Z	Recessive
X	L or Open	X	Z	Z	Recessive

(1) H= High level; L=Low level; Z=High impedance.

Table3. Receiver Function

INPUTS		OUTPUTS	
BUS STATE	$V_{ID}=CANH-CANL$	EN	R
Dominant	$V_{ID} \geq 0.9V$	H	L
Recessive	$V_{ID} \leq 0.5V$ or open	H	H
?	$0.5 < V_{ID} < 0.9V$	H	?
X	X	L or open	H

(1) H=High level; L=Low level; ?=uncertain; X=Irrelevant.

TEST CIRCUIT

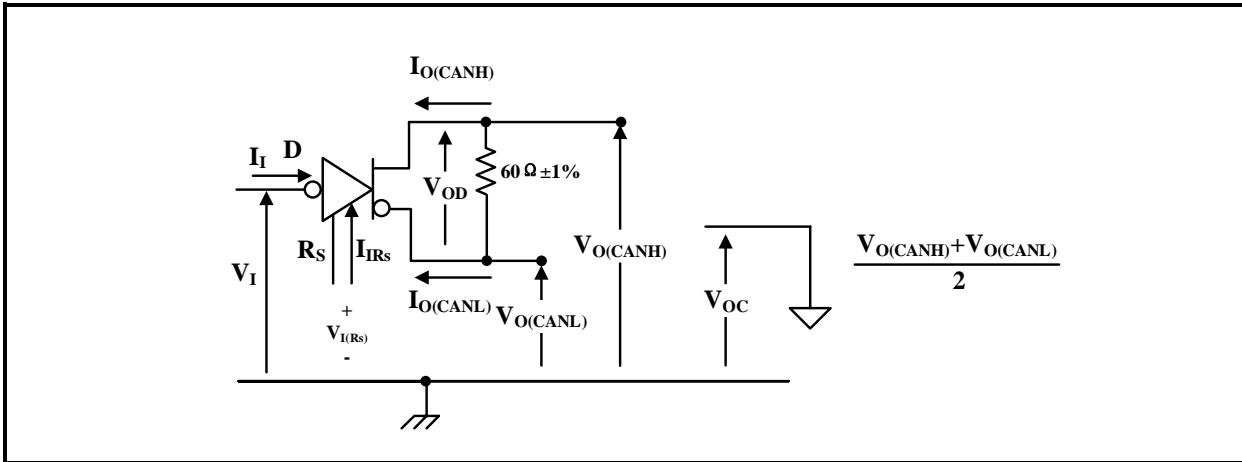

Fig.1 Driver voltage, current and test definition

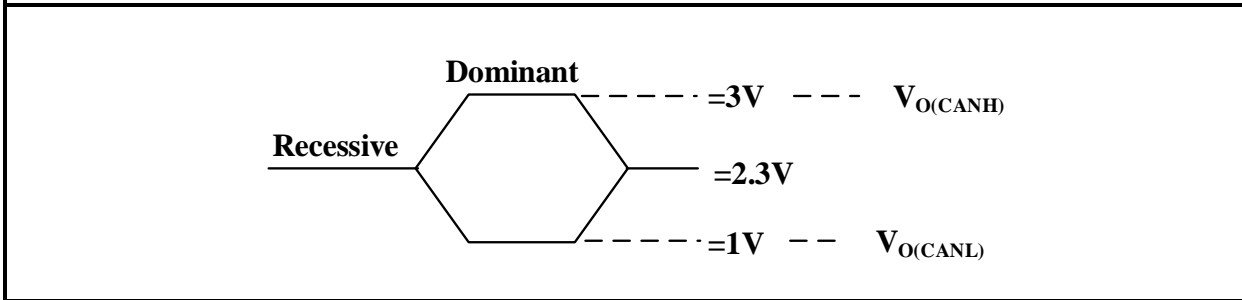

Fig.2 Bus logic state voltage definitions

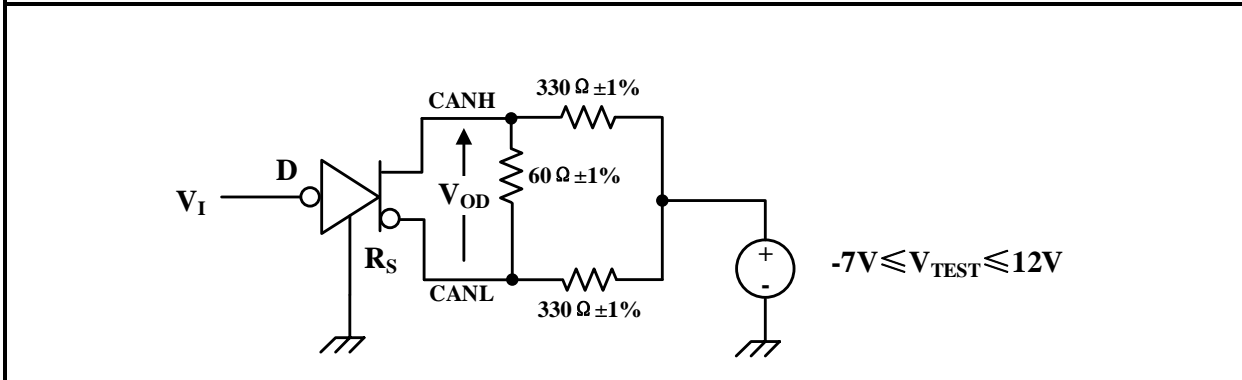
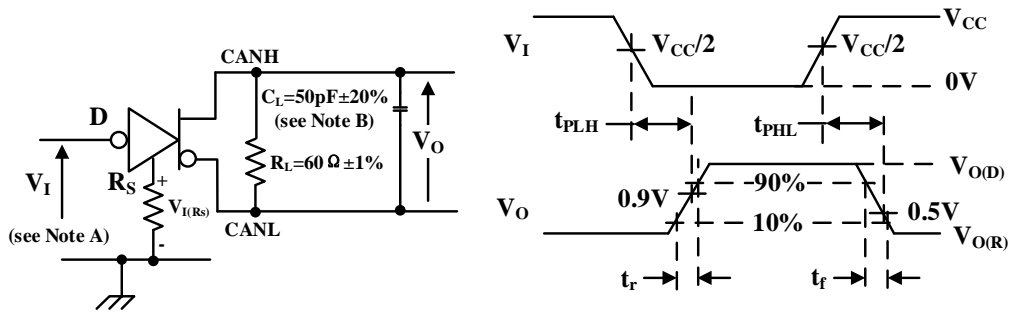
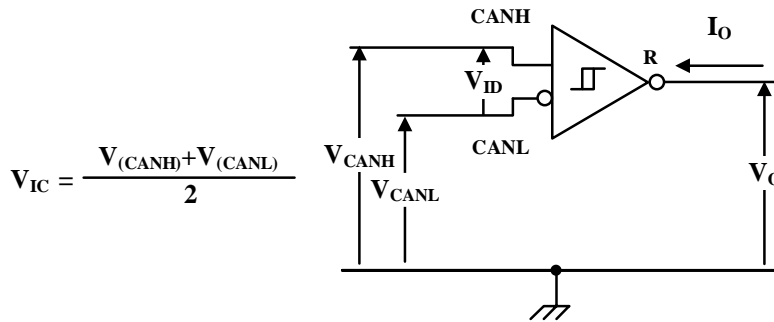
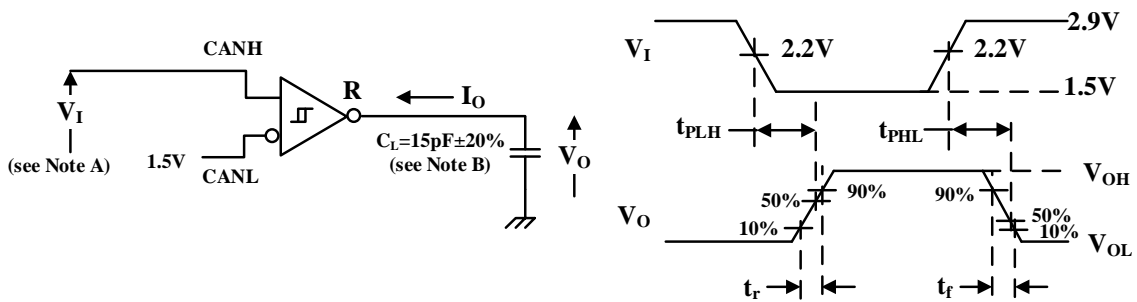

Fig.3 Driver V_{OD} test circuit



- A、 The input pulse is supplied by a generator having the following characteristics: $PRR \leq 125\text{kHz}$, 50% duty cycle, $t_r < 6\text{ns}$, $t_f < 6\text{ns}$, $Z_o = 50\Omega$.
- B、 C_L includes fixture and instrumentation capacitance, the error is within 20%.

Fig.4 Driver test circuit and waveforms

Fig.5 Receiver voltage and current definitions

- A、 The input pulse is supplied by a generator having the following characteristics: $PRR \leq 125\text{kHz}$, 50% duty cycle, $t_r < 6\text{ns}$, $t_f < 6\text{ns}$, $Z_o = 50\Omega$.
- B、 C_L includes fixture and instrumentation capacitance, the error is within 20%.

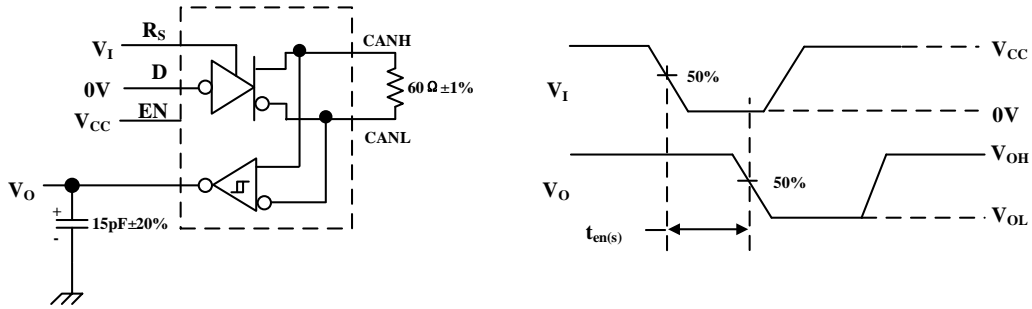
Fig.6 Receiver test circuit and waveform



The input pulse is supplied by a generator having the following characteristics: $PRR \leq 125\text{kHz}$, 50% duty cycle, $t_r < 6\text{ns}$, $t_f < 6\text{ns}$.

Fig.7 t_{WAKE} test circuit and waveform (standby)

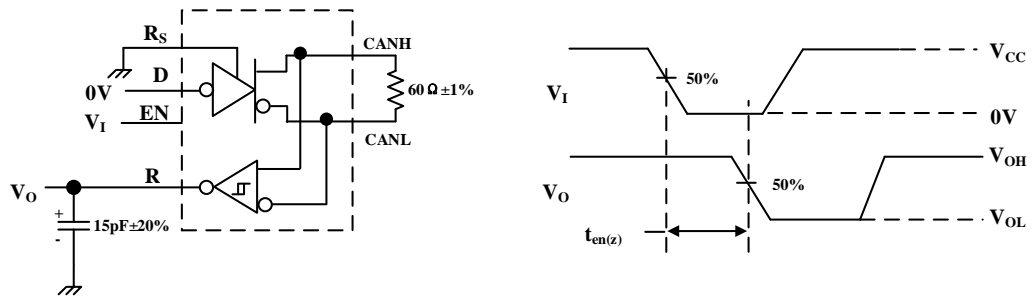

The input pulse is supplied by a generator having the following characteristics: $PRR \leq 50\text{kHz}$, 50% duty cycle, $t_r < 6\text{ns}$, $t_f < 6\text{ns}$.

Fig.8 t_{WAKE} test circuit and waveform (sleep)

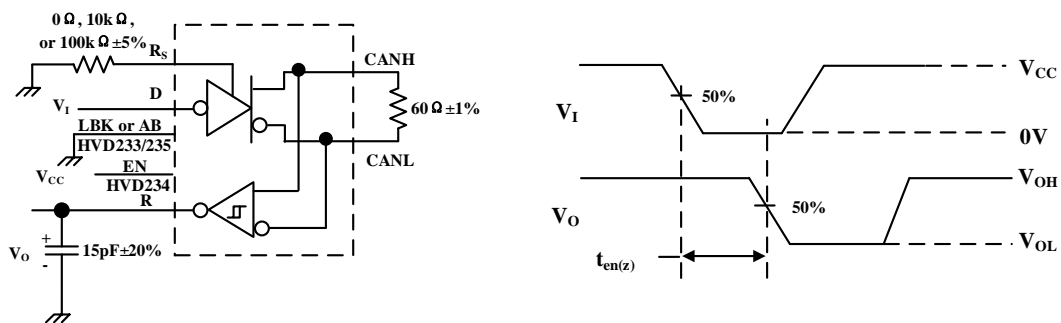

The input pulse is supplied by a generator having the following characteristics: $PRR \leq 125\text{kHz}$, 50% duty cycle, $t_r < 6\text{ns}$, $t_f < 6\text{ns}$, $Z_o = 50\Omega$.

Fig.9 t_{LOOP} test circuit and waveform

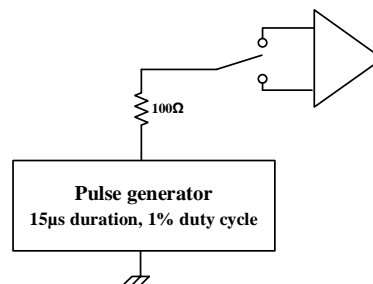

Fig.10 Overvoltage protection

ADDITIONAL DESCRIPTION

1 Sketch

The SIT65HVD234 is the interface between the Controller Area Network (CAN) protocol controller and the physical bus. It is designed for use with the 3.3V μ Ps, MCUs and DSPs with CAN controllers, or with equivalent protocol controller devices. It is used in industrial automation, control, sensors and drive systems, motor and robotic control, building and climate control (HVAC), telecom and base station control and status. It supports programmable data rates up to 1 Mbps. The devices are intended for use in applications employing the CAN serial communication physical layer in accordance with the ISO 11898 standard.

2 Current protection

A current-limiting circuit protects the transmitter output stage from damage caused by accidental short-circuit to either positive or negative supply voltage, although power dissipation increases during this fault condition.

3 Over temperature protection

SIT65HVD234 has the function of over temperature protection. After the over temperature protection is triggered, the current of the driving stage will be reduced, because the driving tube is the main energy consuming part. The current reduction can reduce the power consumption and thus reduce the chip temperature. At the same time, other parts of the chip still work normally.

4 Transient protection

Electrical transients often occur in automotive application environment, CANH, CANL of SIT65HVD234 have the function of preventing electrical transient damage.

5 Operating modes

The R_s pin mode, slop (pin 8) of the SIT65HVD234 provides three different modes of operation: high-speed mode, slope-control mode, and low-power mode.

5.1 High-Speed Mode

The high-speed mode can be selected by applying a logic low to the R_s pin (pin 8). The high-speed mode of operation is commonly employed in industrial applications. High-speed allows the output to switch as fast as possible with no internal limitation on the output rise and fall slopes. If the high-speed transitions are a concern for emissions performance slope control mode can be used.

If both high-speed mode and the low-power standby mode is to be used in the application, direct connection to a μ P, MCU or DSP general purpose output pin can be used to switch between a logic-low level ($< 1.2\text{ V}$) for high-speed operation, and the logic-high level ($> 0.75\text{ VCC}$) for standby.

5.2 Slope Control Mode

Electromagnetic compatibility is essential in many applications while still making use of unshielded twisted pair bus cable to reduce system cost. Slope control mode was added to the SIT65HVD234 devices to reduce the electromagnetic interference produced by the rise and fall times of the driver and resulting harmonics. These rise and fall slopes of the driver outputs can be adjusted by connecting a resistor from R_s (pin 8) to ground or to a logic low voltage. The slope of the driver output signal is proportional to the pin's output current. This slope control is implemented with an external resistor value of $10k\Omega$ to $100k\Omega$ to achieve slew rate.

5.3 Standby Mode (Listen Only Mode)

If a logic high ($> 0.75 V_{CC}$) is applied to R_s (pin 8), the circuit of the SIT65HVD234 enters a low-current, listen only standby mode, during which the driver is switched off and the receiver remains active. In this listen only state, the transceiver is completely passive to the bus. It makes no difference if a slope control resistor is in place. The μP can reverse this low-power standby mode when the rising edge of a dominant state (bus differential voltage $> 900 mV$ typical) occurs on the bus. The μP , sensing bus activity, reactivates the driver circuit by placing a logic low ($< 1.2 V$) on R_S (pin 8).

6 Enable control function

The enable control function of SIT65HVD234 is controlled by pin 5 EN. When EN is at a low level, the device circuit enters a very low power sleep mode, in which the driver and receiver are not working. The drive will remain dormant until the EN port detects a HIGH signal.

SOP8 DIMENSIONS
PACKAGE SIZE

SYMBOL	MIN./mm	TYP./mm	MAX./mm
A	1.40	-	1.80
A1	0.10	-	0.25
A2	1.30	1.40	1.50
b	0.38	-	0.51
D	4.80	4.90	5.00
E	3.80	3.90	4.00
E1	5.80	6.00	6.20
e		1.270BSC	
L	0.40	0.60	0.80
c	0.20	-	0.25
θ	0°	-	8°

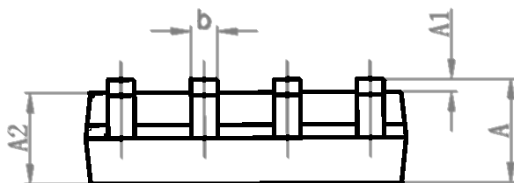
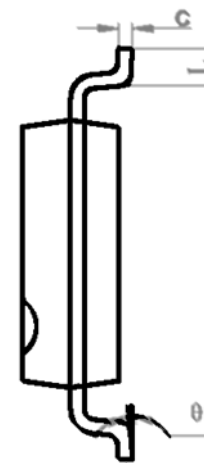
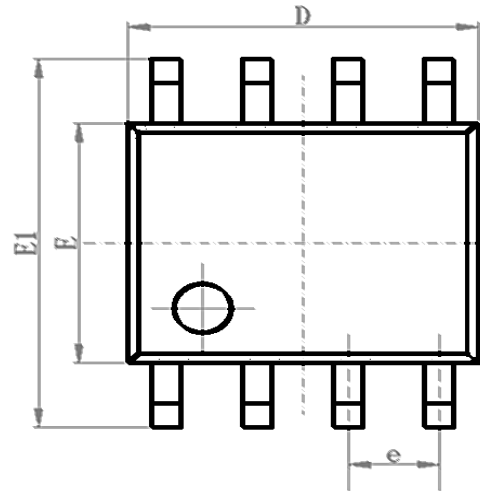

DIP8 DIMENSIONS
PACKAGE SIZE

SYMBOL	MIN./mm	TYP./mm	MAX./mm
A	9.00	9.20	9.40
A1	0.33	0.45	0.51
A2	2.54TYP		
A3	1.525TYP		
B	8.40	8.70	9.10
B1	6.20	6.40	6.60
B2	7.32	7.62	7.92
C	3.20	3.40	3.60
C1	0.50	0.60	0.80
C2	3.71	4.00	4.31
D	0.20	0.28	0.36
L	3.00	3.30	3.60

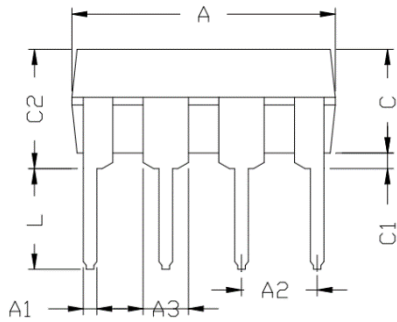
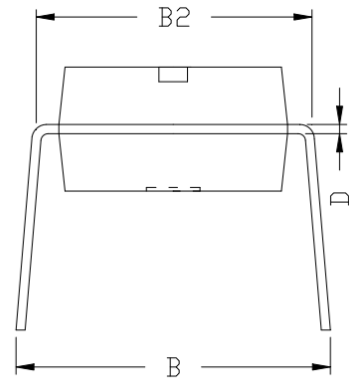
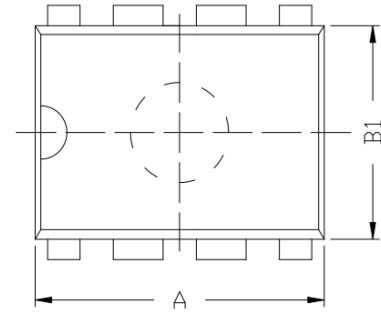

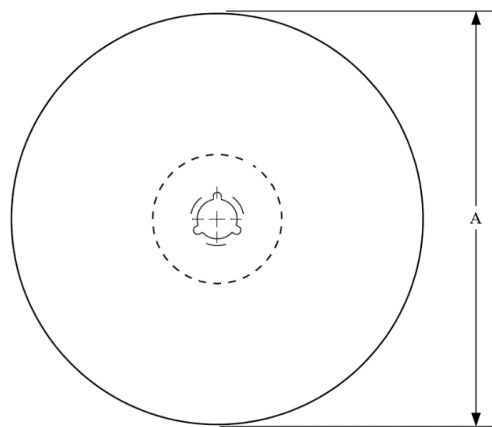
TAPE AND REEL INFORMATION

A0	Dimension designed to accommodate the component width
B0	Dimension designed to accommodate the component length
K0	Dimension designed to accommodate the component thickness
W	Overall width of the carrier tape
P1	Pitch between successive cavity centers

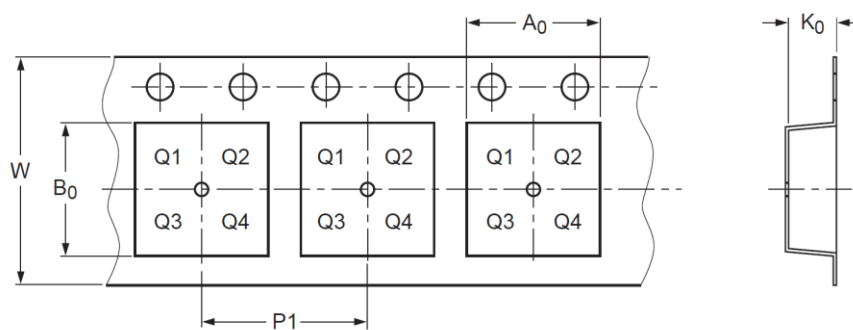
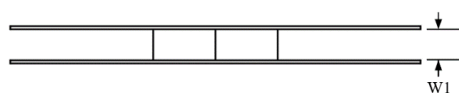

Direction of Feed →

PIN1 is in quadrant 1

Package Type	Reel Diameter A (mm)	Tape width W1 (mm)	A0 (mm)	B0 (mm)	K0 (mm)	P1 (mm)	W (mm)
SOP8	330±2	12.4±0.40	6.50±0.1	5.30±0.10	2.05±0.1	8.00±0.1	12.00±0.1

ORDERING INFORMATION

TYPE NUMBER	PACKAGE	PACKING
SIT65HVD234DR	SOP8	Tape and reel
SIT65HVD234P	DIP8	Tube

SOP8 is packed with 2500 pieces/disc in braided packaging. DIP8 is packed with 50 pieces/tube in tube packaging.

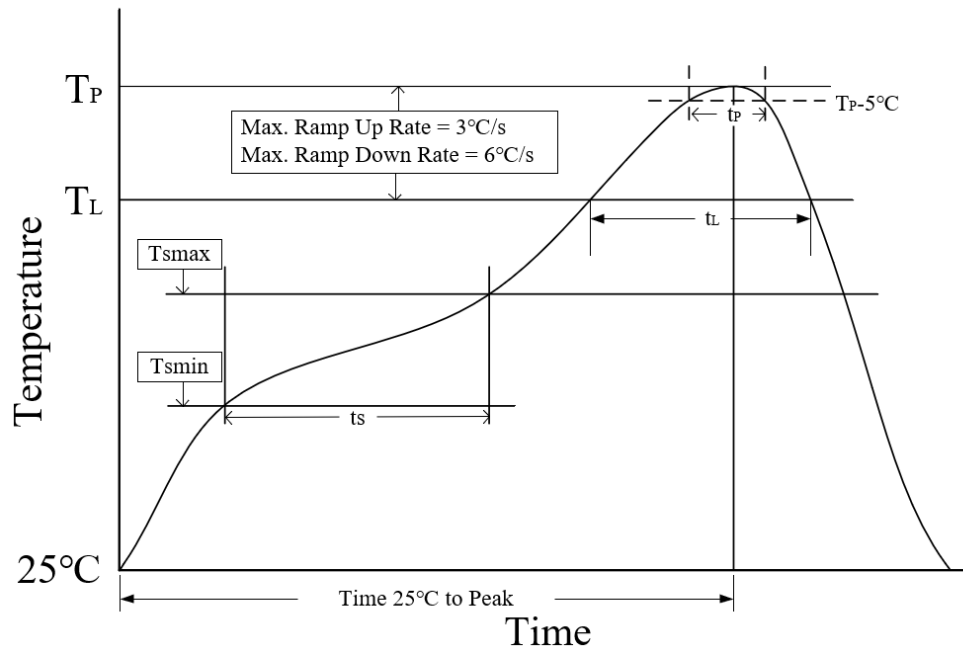
REFLOW SOLDERING

Parameter	Lead-free soldering conditions
Ave ramp up rate (T_L to T_P)	3°C/second max
Preheat time t_s ($T_{smin}=150^{\circ}\text{C}$ to $T_{smax}=200^{\circ}\text{C}$)	60-120 seconds
Melting time t_L ($T_L=217^{\circ}\text{C}$)	60-150 seconds
Peak temp T_P	260-265°C
5°C below peak temperature t_p	30 seconds
Ave cooling rate (T_P to T_L)	6°C/second max
Normal temperature 25°C to peak temperature T_P time	8 minutes max

Important statement

SIT reserves the right to change the above-mentioned information without prior notice.

VERSION HISTORY

Version number	Data sheet status	Revision Date
V1.0	Initial version.	October 2022