



**INPAQ**

---

# PRODUCT SPECIFICATION

**DOCUMENT NO. ENS000140690**

<b>DESCRIPTION</b>	<b>DRAWN BY</b>	<b>DESIGNED BY</b>	<b>CHECKED BY</b>	<b>APPROVED BY</b>
AIP0630MB Series	Annie	Peter	Logan	Phil





## Molding Type Power Choke

### Scope

#### Features

- ROHS, Halogen Free and REACH compliance
- Flux shielded structure
- High rated current
- 125 °C maximum total temperature operation
- 7.3x6.8x3.0 mm maximum surface mount package
- Low core loss
- Ultra low buzz noise due to molding construction

#### Applications

- Laptops and PCs
- Switch and servers
- Base stations
- DC / DC converters
- SSD modules
- Battery powered devices

### Explanation of Part Number

**A I P 0 6 3 0 M B - 1 R 0 M**

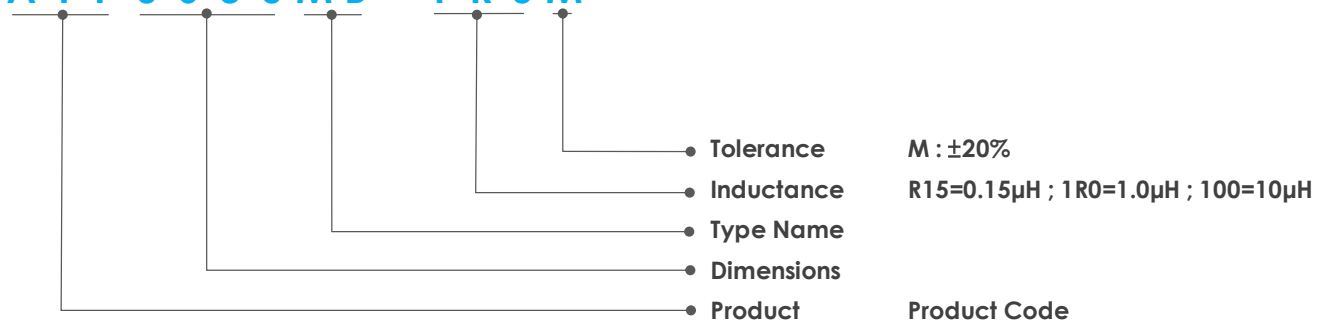

## Dimensions

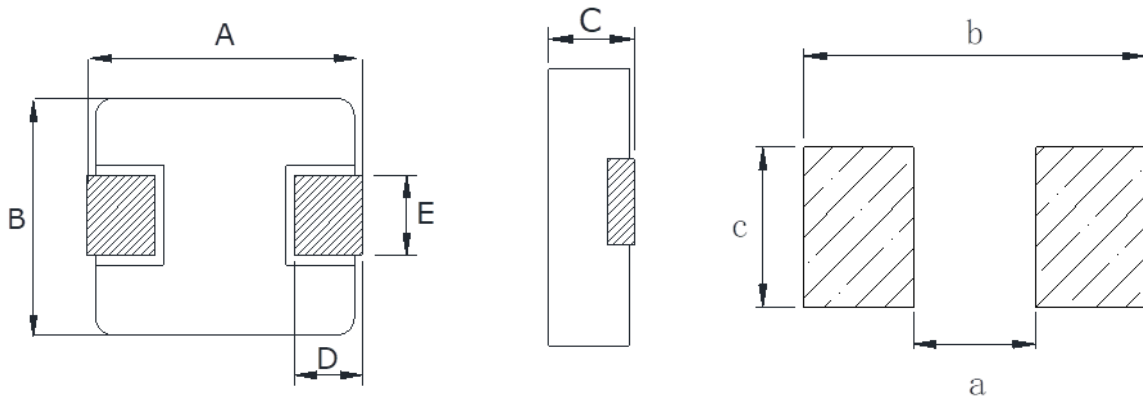

Recommend Land Pattern

unit (mm)

A	B	C	D	E	a Typ.	b Typ.	c Typ.
7.0±0.3	6.6±0.2	2.8±0.2	1.6±0.3	3.0±0.3	3.7	8.4	3.5

## Marking

The inductor is marked with a 3-digit code (using ink for marking).

Example: R24 means 0.24μH  
 1R0 means 1.0μH  
 100 means 10μH

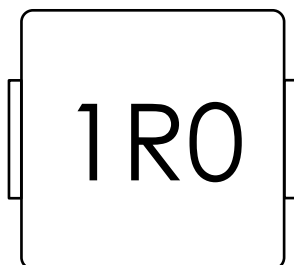

## Structure and Components

Symbo	Component	Material
a	Marking	Ink (black)
b	Core	Alloy sponge powder
c	Wire	Polyurethane copper wire
d	Terminal	Copper plated with Sn

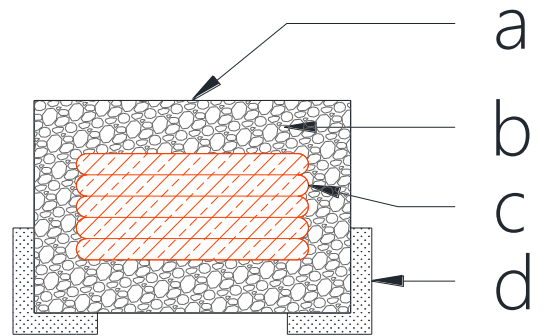

## Specifications

6x6 Series PN	Li [ $\mu$ H]	Rdc [ $m\Omega$ ]		Isat [A]		Irms [A]	
	Initial Value	DC resistance		Li drop 30%		Temp. rising 40°C	
	+/-20%	typ.	max.	typ.	max.	typ.	max.
<b>AIP0630MB-R15M</b>	<b>0.15</b>	<b>1.8</b>	<b>2.4</b>	<b>41</b>	<b>35</b>	<b>30</b>	<b>25</b>
<b>AIP0630MB-R22M</b>	<b>0.22</b>	<b>2.3</b>	<b>3</b>	<b>35</b>	<b>32</b>	<b>25</b>	<b>21</b>
<b>AIP0630MB-R33M</b>	<b>0.33</b>	<b>2.7</b>	<b>3.3</b>	<b>26</b>	<b>22</b>	<b>22</b>	<b>20</b>
<b>AIP0630MB-R47M</b>	<b>0.47</b>	<b>3.48</b>	<b>4.1</b>	<b>21</b>	<b>17.8</b>	<b>18</b>	<b>16</b>
<b>AIP0630MB-R56M</b>	<b>0.56</b>	<b>3.88</b>	<b>4.5</b>	<b>20</b>	<b>16</b>	<b>16.5</b>	<b>15</b>
<b>AIP0630MB-R68M</b>	<b>0.68</b>	<b>4.75</b>	<b>5.3</b>	<b>19</b>	<b>15</b>	<b>16</b>	<b>14.5</b>
<b>AIP0630MB-R82M</b>	<b>0.82</b>	<b>5.38</b>	<b>6</b>	<b>17</b>	<b>14</b>	<b>14</b>	<b>13</b>
<b>AIP0630MB-1R0M</b>	<b>1.0</b>	<b>6.6</b>	<b>7.25</b>	<b>16.5</b>	<b>13.5</b>	<b>13</b>	<b>11.2</b>
<b>AIP0630MB-1R2M</b>	<b>1.2</b>	<b>7.7</b>	<b>8.6</b>	<b>14.5</b>	<b>12.5</b>	<b>11.7</b>	<b>10.1</b>
<b>AIP0630MB-1R5M</b>	<b>1.5</b>	<b>9.1</b>	<b>10.5</b>	<b>14.2</b>	<b>12</b>	<b>12</b>	<b>9.5</b>
<b>AIP0630MB-2R2M</b>	<b>2.2</b>	<b>13.4</b>	<b>15</b>	<b>12.5</b>	<b>10.5</b>	<b>9.5</b>	<b>8</b>
<b>AIP0630MB-3R3M</b>	<b>3.3</b>	<b>17.9</b>	<b>22</b>	<b>9.6</b>	<b>8.5</b>	<b>8.5</b>	<b>6.2</b>
<b>AIP0630MB-4R7M</b>	<b>4.7</b>	<b>27.9</b>	<b>33</b>	<b>9.2</b>	<b>8.1</b>	<b>6</b>	<b>5.5</b>
<b>AIP0630MB-5R6M</b>	<b>5.6</b>	<b>39</b>	<b>42</b>	<b>6.5</b>	<b>5.2</b>	<b>5.7</b>	<b>5</b>
<b>AIP0630MB-6R8M</b>	<b>6.8</b>	<b>42</b>	<b>48</b>	<b>6.3</b>	<b>5</b>	<b>5</b>	<b>4.2</b>
<b>AIP0630MB-8R2M</b>	<b>8.2</b>	<b>53.9</b>	<b>60</b>	<b>6</b>	<b>4.9</b>	<b>4.7</b>	<b>3.8</b>
<b>AIP0630MB-100M</b>	<b>10</b>	<b>60</b>	<b>68</b>	<b>5.6</b>	<b>4.9</b>	<b>4.5</b>	<b>3.5</b>
<b>AIP0630MB-150M</b>	<b>15</b>	<b>100</b>	<b>113</b>	<b>4.2</b>	<b>3.5</b>	<b>3</b>	<b>2.4</b>
<b>AIP0630MB-220M</b>	<b>22</b>	<b>140</b>	<b>170</b>	<b>3.1</b>	<b>2.5</b>	<b>2.5</b>	<b>2</b>
<b>AIP0630MB-330M</b>	<b>33</b>	<b>195</b>	<b>270</b>	<b>2.5</b>	<b>2</b>	<b>2.1</b>	<b>1.8</b>
<b>AIP0630MB-470M</b>	<b>47</b>	<b>340</b>	<b>385</b>	<b>2.2</b>	<b>1.8</b>	<b>1.5</b>	<b>1.2</b>

### Notes

1. Test environment of all data is referenced to 25 °C ambient.
2. Test conditions: 100 KHz, 1Vrms.
3. Isat : DC current (A) that will cause L to drop approximately 30 %.
4. Irms : DC current (A) that will cause an approximate  $\Delta T$  of 40 °C (reference ambient temperature is 25°C).
5. Operating temperature range – 55 °C to + 125 °C.
6. The part temperature (ambient + temp rise) should not exceed 125 °C under worst case operating conditions. Circuit design, component placement, PWB trace size and thickness, airflow and other cooling provisions all affect the part temperature. Part temperature should be verified in the end application.

## Mechanical Reliability

Item	Specification and Requirement	Test Method
Solderability	<ol style="list-style-type: none"> <li>No case deformation or change in appearance.</li> <li>New solder coverage More than 95%.</li> </ol>	<ol style="list-style-type: none"> <li>Preheat : 155 °C ± 5 °C, 60S ± 2S.</li> <li>Tin : lead-free.</li> <li>Temperature : 240 °C ± 5 °C, flux 3.0S ± 0.5S.</li> </ol>
Mechanical shock	<ol style="list-style-type: none"> <li>No case deformation or change in appearance.</li> <li><math>\Delta L / L_0 \leq \pm 10\%</math>.</li> </ol>	<ol style="list-style-type: none"> <li>Acceleration : 100G.</li> <li>Pulse time : 6ms.</li> <li>3 times in each positive and negative direction of 3 mutual perpendicular directions.</li> </ol>
Mechanical vibration	<ol style="list-style-type: none"> <li>No case deformation or change in appearance.</li> <li><math>\Delta L / L_0 \leq \pm 10\%</math>.</li> </ol>	<ol style="list-style-type: none"> <li>Reflow : 2 times.</li> <li>Frequency : 10Hz~55Hz~10Hz, 20 min / cycles.</li> <li>Amplitude : 1.52 mm.</li> <li>Directions : X, Y, Z.</li> <li>Time : 12 cycle / direction.</li> </ol>

## Endurance Reliability

Item	Specification and Requirement	Test Method
Thermal Shock	Inductance change : Within ± 10% Without distinct damage in appearance.	<ol style="list-style-type: none"> <li>First -55 °C for 30 minutes, last 125 °C for 30 minutes as 1 cycle. Go through 1000 cycles.</li> <li>Max transfer time is 3 minutes.</li> <li>Measured at room temperature after placing for 24 ± 2 hours.</li> </ol>
Humidity Resistance	Inductance change : Within ± 10% Without distinct damage in appearance.	<ol style="list-style-type: none"> <li>Reflow 2 times.</li> <li>85 °C, 85% RH, 1000 hours.</li> <li>Measured at room temperature after placing for 24 ± 2 hours.</li> </ol>
Low temperature storage	Inductance change : Within ± 10% Without distinct damage in appearance.	<ol style="list-style-type: none"> <li>Temperature : -55 ± 2 °C.</li> <li>Time : 1000 hours.</li> <li>Measured at room temperature after placing for 24 ± 2 hours.</li> </ol>
High temperature storage	Inductance change : Within ± 10% Without distinct damage in appearance.	<ol style="list-style-type: none"> <li>Temperature : +125 ± 2°C.</li> <li>Time : 1000 hours.</li> <li>Measured at room temperature after placing for 24 ± 2 hours.</li> </ol>

## Recommended Soldering Technologies

### (1) Re-flowing Profile

- Preheat condition : 150 ~ 200 °C / 60 ~ 120 sec.
- Allowed time above 217 °C : 60 ~ 90 sec.
- Max. temp : 260 °C.
- Max. time at max temp : 5 sec.
- Solder paste : Sn / 3.0Ag / 0.5Cu.
- Allowed Reflow time : 2 times.

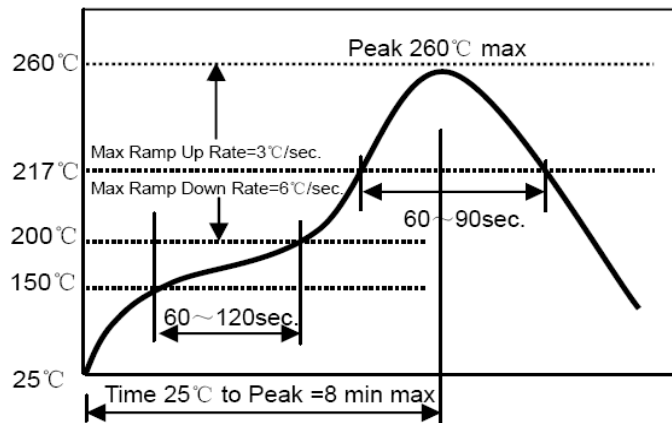

### (2) Iron Soldering Profile

- Iron soldering power : Max. 30W.
- Pre-heating : 150 °C / 60 sec.
- Soldering Tip temperature : 350°C max.
- Soldering time : 3 sec. max.
- Solder paste : Sn / 3.0Ag / 0.5Cu.
- Max. 1 times for iron soldering.

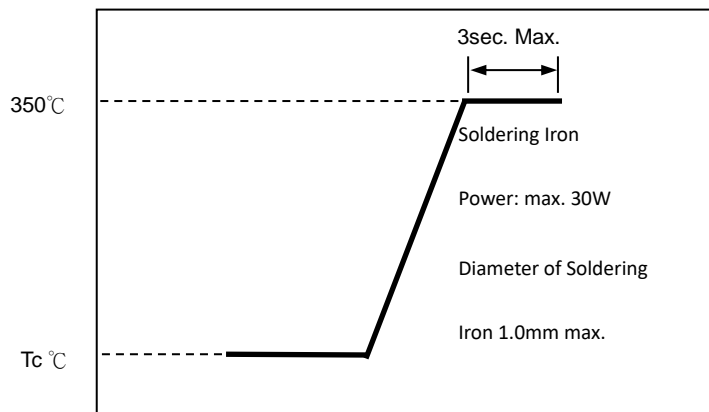



## Taping Package and Label Marking

### ► Taping reel dimensions (unit : mm)

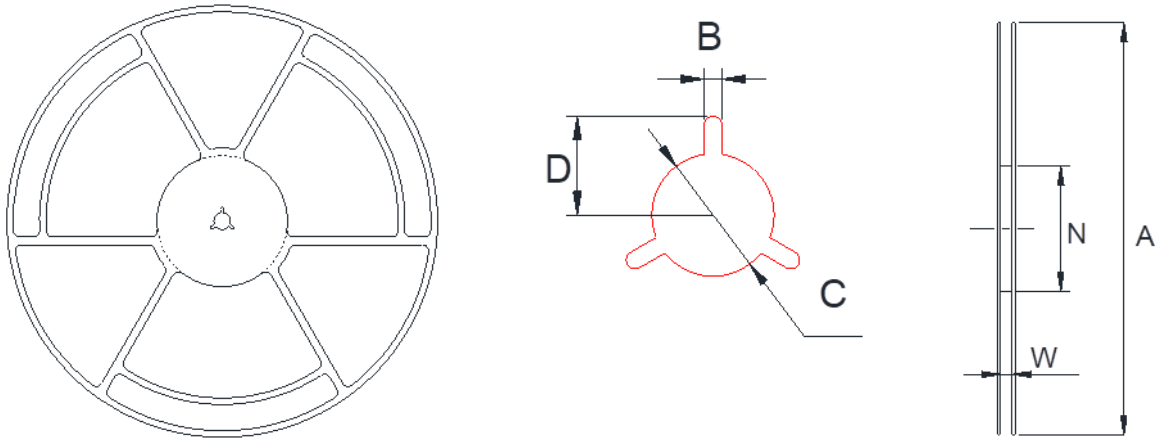

A	W	N	B	C	D
330+2.0	16.8+0.2	97+0.5	2.2+0.5	13.2±0.2	10.75±0.25

### ► Carrier tape dimensions

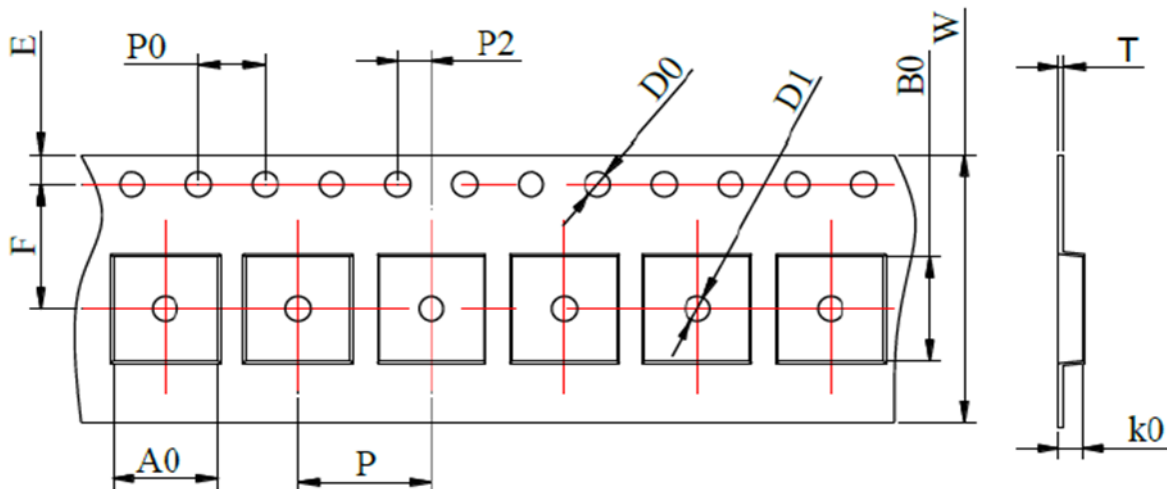

Type	Tape dimensions (unit : mm)											
	W	P	P0	P2	D0	D1	T	A0	B0	K0	E	F
AIP0630MB	16 ±0.3	12 ±0.1	4 ±0.1	2 ±0.1	1.5 ±0.1	1.5 ±0.1	0.35 ±0.05	6.9 ±0.1	7.5 ±0.1	3.3 ±0.1	1.75 ±0.1	7.5 ±0.1

► Taping Drawings (unit : mm)

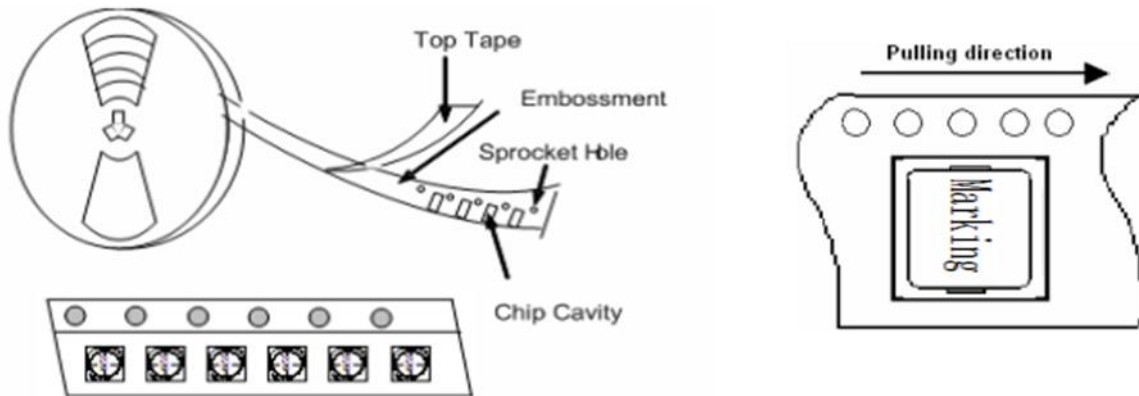

► Label Marking

The label specified as follows shall be put on the side of reel.

- (1) Part No.
- (2) Quantity.
- (3) Lot No.

\* Part No. And Quantity shall be marked on outer packaging.

► Quantity of products in the package

Type	Standard Quantity
AIP0630MB	1500 pcs / reel

► Peel force of top cover tape

The peel speed shall be about 300 mm / minute.

The peel force of top cover tape shall be between 0.1 to 1.3N.

