

## 30W PD-12V

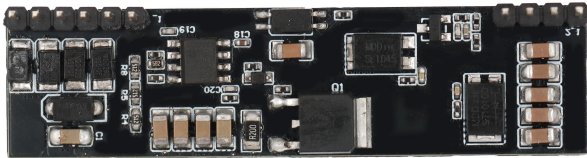

## Product Characteristics

- Compliance with IEEE802.3AT standard.(downward compatibility AF)
- 42V~57V wide operating voltage range.
- Maximum output power up to 30W; Rated output: 12V/2.5A
- The output ripple is less than 100 mV.
- Conversion efficiency can be as high as 88% (input: 48V output: 12V@2.5A)
- It has excellent reliability and circuit protection such as over current, short circuit, under voltage and surge
- PCBA standard size: 62\*16.0\*16mm
- Input/Output: isolate 1500Vdc
- Class 4 IEEE802.3 PD
- High reliability: The design meets the 5 million hour average failure interval

## Scope of Application

- Video and VoIP Phone
- RFID Reader
- Multiband Access Point
- Surveillance camera

## Describe

- The PoE (power over Ethernet) module is a traditional Category 5 and 6 twisted pair Ethernet power supply module based on the IEEE 802.3AT PoE standard
- Designed to extract power from power supply equipment (PSE) through conventional twisted pair Category 5 and Category 6 Ethernet cables. Module inputs comply with IEEE803.2AT signature recognition and classification standards
- Pre configured as a Type 1, Level 3 device, allowing the module to obtain class 3 power from the PSE with a rated output voltage of 12V. Efficient DC/DC converters can achieve an efficiency of about 88% and operate within a wide input voltage range, with low ripple and low noise output. The DC/DC converter also has built-in output overload and short circuit protection, and provides 1500Vdc (input/output) isolation barrier

## Mechanical Dimensions

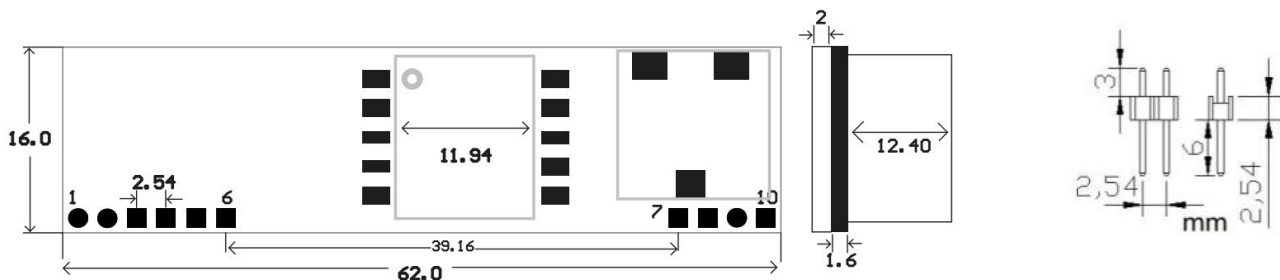

Unit: mm;

Unmarked tolerances: ±0.5

## Pin Definition

Pin	Name	Describe
1,5	VA1	Connect to RJ45 network port (TX) 1 and 2 pin network transformer central taps. (The module carries two sets of rectifier bridges to suit different PSE power supply directions)
2,6	VA2	Connect to RJ45 network port (TX) 3 and 6 pin network transformer center taps. (The module carries two sets of rectifier bridges to suit different PSE power supply directions)
3	VB1	Connect to RJ45 network port 4 and 5 pins (100Mbps), or connect to RJ45 network port (BI) 4 and 5 pins network transformer center tap (100Mbps) (the module is equipped with two sets of rectifier bridges to adapt to different PSE power supply directions)
4	VB2	Connect to RJ45 network port 7 and 8 pins (100Mbps), or connect to RJ45 network port (BI) 7 and 8 pins network transformer center tap (100Mbps) (the module is equipped with two sets of rectifier bridges to adapt to different PSE power supply directions)
7,8	Vout-	This pin is the module output negative pole
9,10	Vout+	This pin is the module output positive pole

## Electrical Characteristics

### Absolute Maximum Rating Parameter

No	Parameter	Symbol	MIN	MAX	Unit
1	Input DC voltage	VCC	42	57	V
2	DC Voltage Surge 1ms	VSURGE	-0.6	80	V
3	ambient temperature	TS	-40	70	°C

- Exceeding the above rating may cause permanent damage to the product. Functional operations under these conditions are not recommended

### Recommended Working Conditions

No	Parameter	Symbol	MIN	TYP	MAX	Unit
1	Input DC voltage	VIN	42	48	57	V
2	Low pressure input threshold	VLOCK	37	-	-	V
3	Ambient Temperature	TOP	-40	25	80	°C

- Only applicable to the maximum operating temperature of WC-PD30C120A-R1 product

### DC Characteristic

No	Parameter	Symbol	MIN	TYP	MAX	Unit	Test Conditions
1	Standard Output Voltage	VDC	11.85	12	12.15	V	VIN=48v
2	Output Current (VIN=48V)	PWR	-	2.5	-	A	Wide voltage input 42-57V
3	Power adjustment rate	VLINE	-	0.1	-	%	@50% Load
4	Load Adjustment Rate	VLOAD	-	1	-	%	@VIN=48V
5	Ripple Output Noise	VRN	-	100	-	mVp-p	@Maximum Load
6	Minimum Load	RLOAD	10	-	-	mA	
7	Short circuit duration	TSC	-	-	∞	sec	
8	Efficiency (load 80%)	EFF	-	88	-	%	
9	Isolation Voltage (I/O)	VISO	-	-	1500	VPK	
10	temperature coefficient	Tc	-	0.02	-	%	Per °C
11	transient response	Ts	-	150	250	ms	VIN=48V VOUT=max

- Typical number is 25 C, nominal voltage is 48V, for auxiliary design only
- Output ripple and noise can be reduced by an external filter, see the application instructions
- If operated under the specified minimum load, the module will emit sound noise, which may cause repeated hiccups in the PSE

## Functional Description

### Input:

- WC-PD30C120A-R1 The input end is bridge stacked to ensure the input polarity protection, and the user can select the connection mode as needed

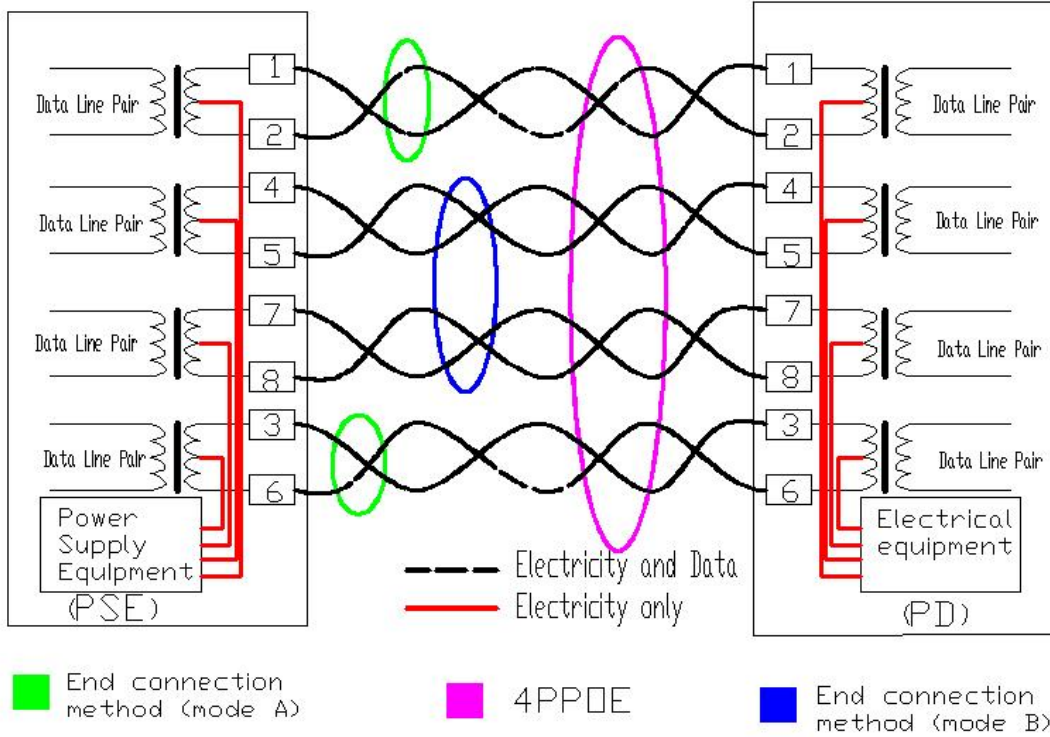

### PD Power Supply Agreement

- When the module is connected to the cable, it will automatically provide the Power Device (PD) signature to the PSE when needed. The PSE recognizes that the PD is connected to that line and provides power.

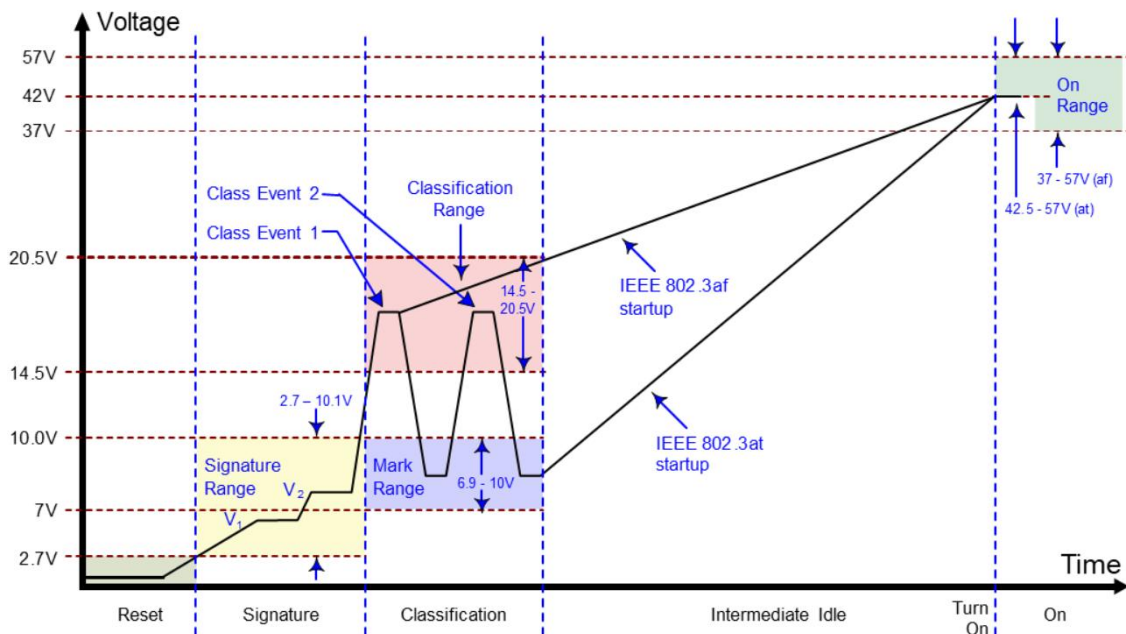

**Power Classification:**

- WC-PD30C120A-R1 adopts IEEE802.3at standard, with default class 4 (30W) rated power
- When using standard ultra six level network cables, under the condition of 30W at 10m, the rated power will gradually decrease with the length of the input conductor

Define Criteria	Cable Requirements	Grading Parameters	Power Supply Characteristics
IEEE802.3at (PoE Plus)	CAT5 cable or CAT6 cable	Maximum power required for Class4 devices is 13W~25.5W	<ol style="list-style-type: none"> <li>The DC voltage ranges from 42 to 57V, with a typical value of 48V.</li> <li>Typical operating current is 10~600mA; typical output power: 25.5W.</li> <li>Class4 rating supported by electrical equipment.</li> </ol>
IEEE802.3bt (PoE++)	CAT5 cable or CAT6 cable	The maximum power required for level 5 equipment is 40W	<ol style="list-style-type: none"> <li>DC voltage range 42 V to 57 V, typical value 52V.</li> <li>Typical working current is 10 ~ 1300 mA; typical output power: 71W;</li> </ol>
		The maximum power required for level 6 equipment is 51W	
		The maximum power required for level 7 equipment is 62W	
		The maximum power required for level 8 equipment is 71W	

**Typical Connection Diagram**

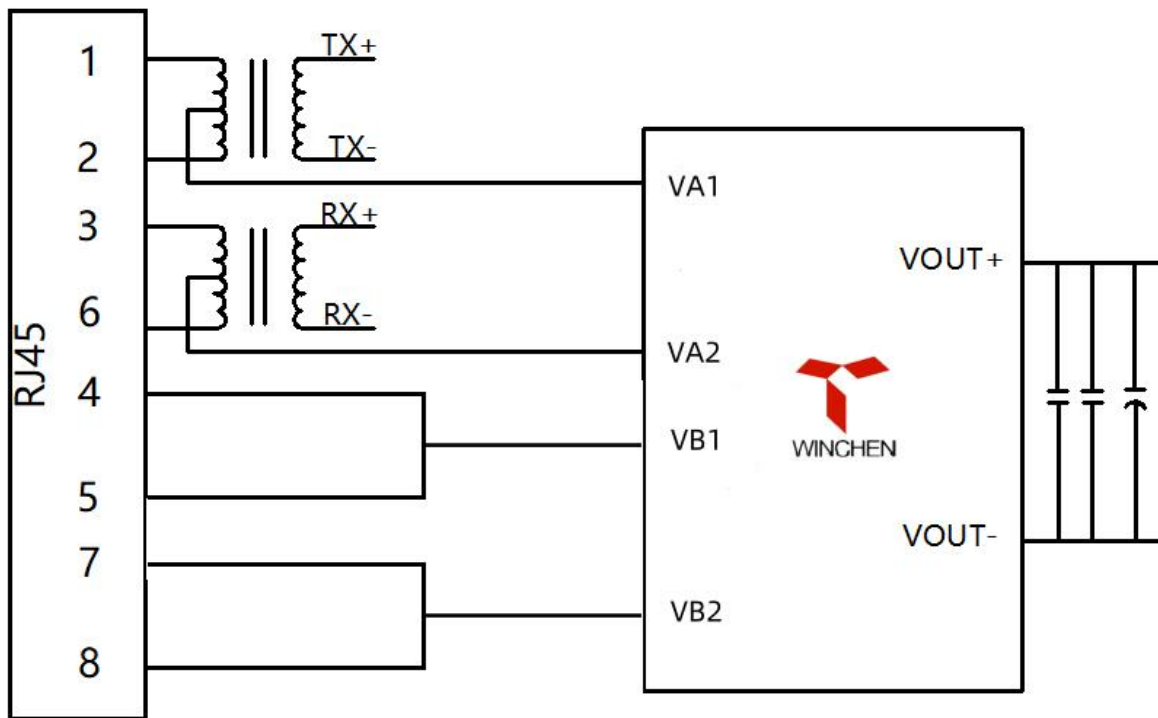

## Typical Applications

- This module is used in the PSE network cable to convert electrical energy into the voltage required for DC-DC to the device without affecting data signal transmission. Complies with IEEE802.3AT standard and is used by all device terminals

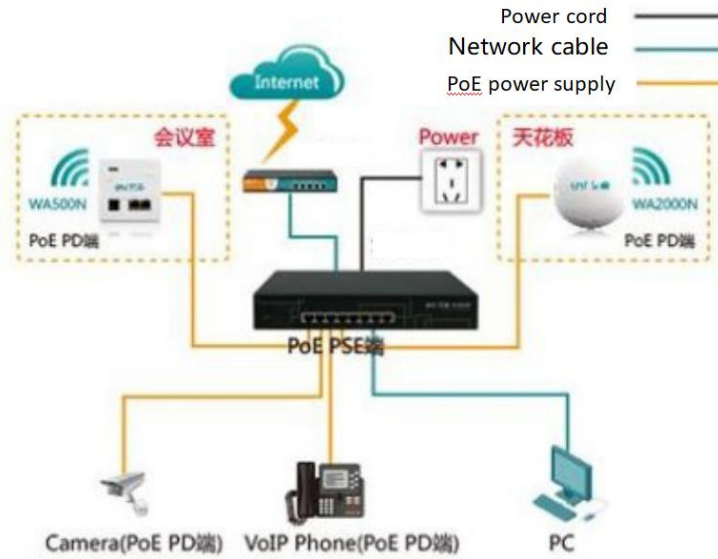

## Test Waveform Diagram

Typical Features: Output voltage = 12V

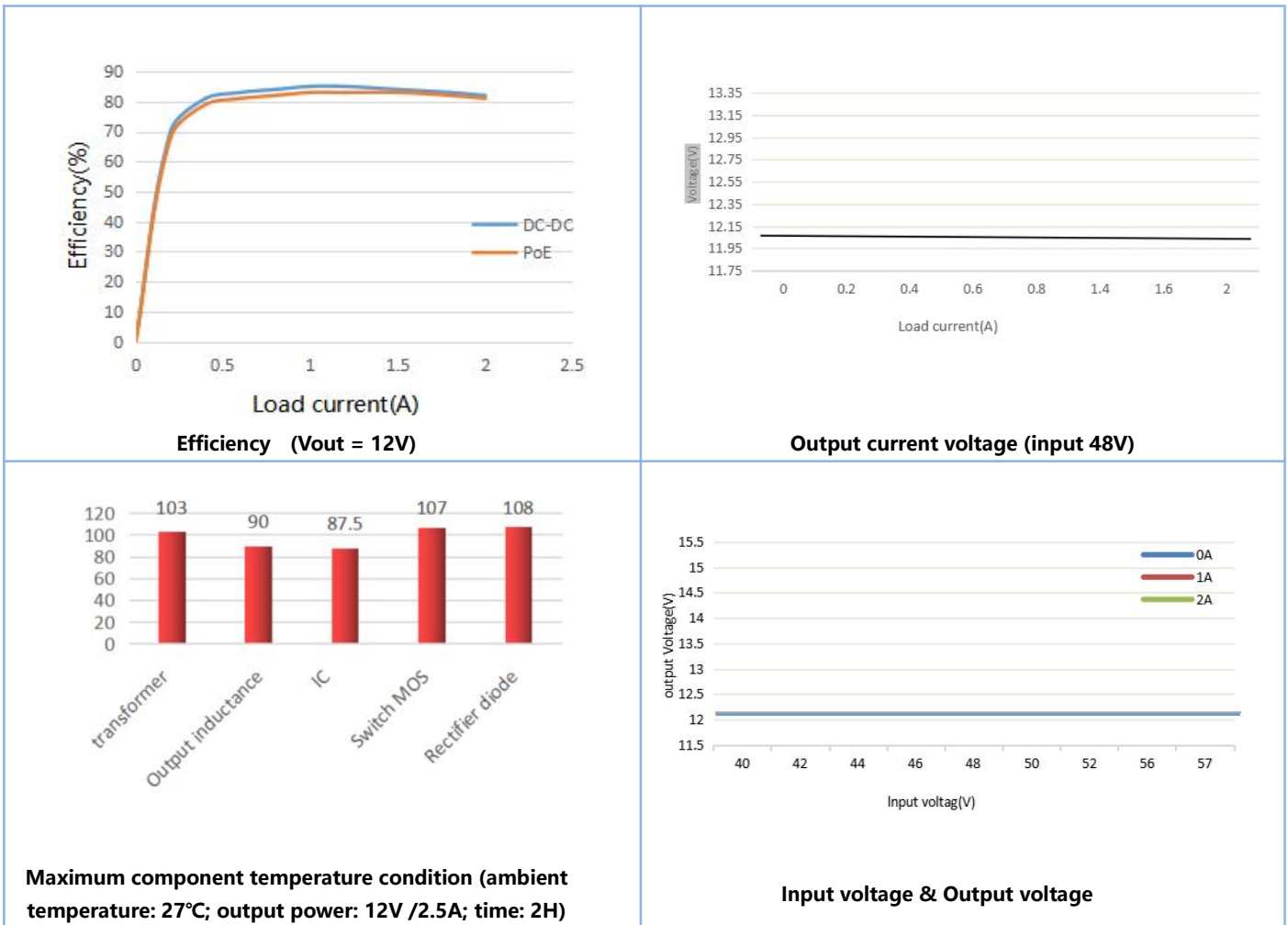

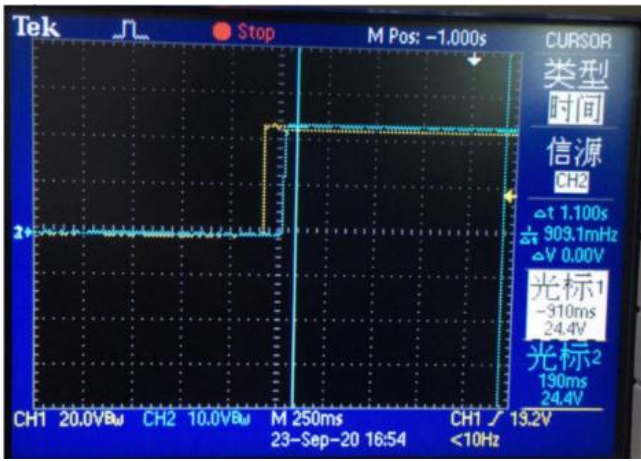

Power on

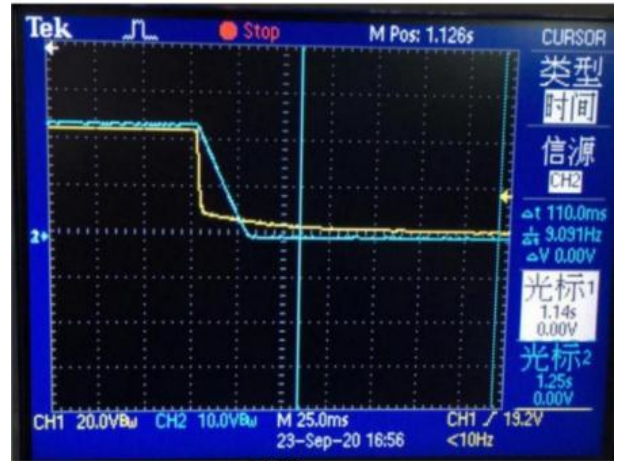

Power down

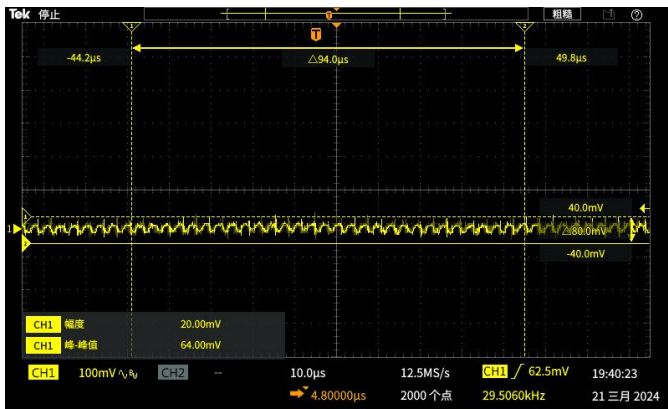

Output ripple (12V /2.5A)

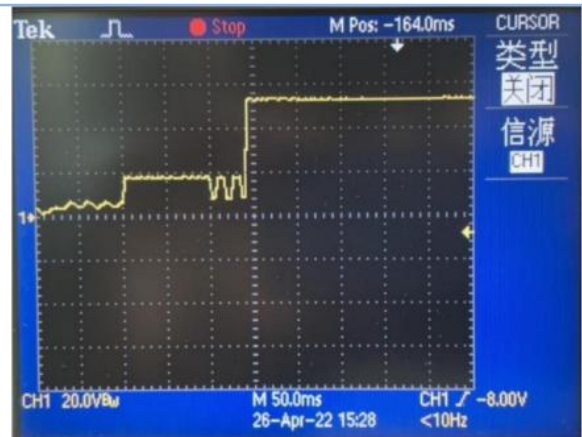

Agreement to shake hands

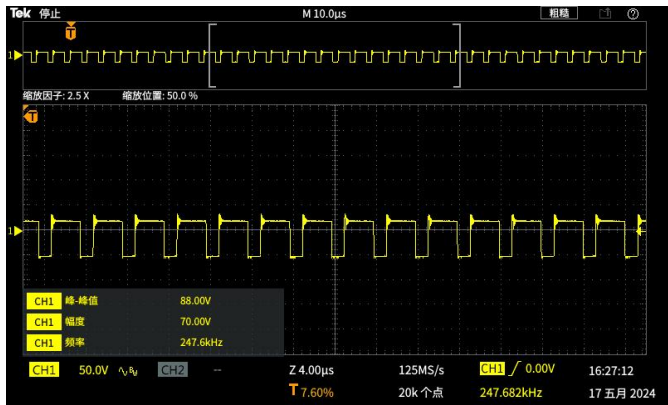

PWM



Output rectifier diode