

25W PD-12V

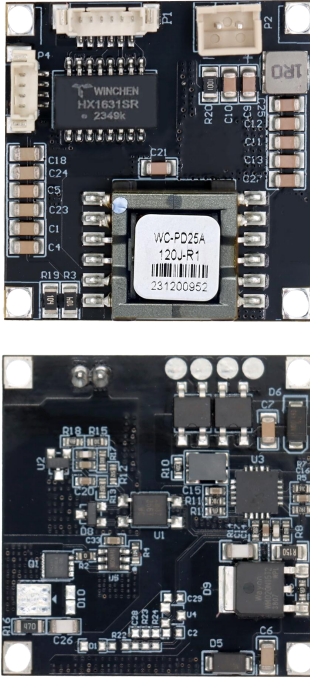

Product characteristics

- Compliance with IEEE802.3at standard(backward compatible with AF)
- 42V~57V wide operating voltage range
- Maximum output power up to 25W; Rated output: 12V/2A
- The output ripple is less than 200 mV
- Conversion efficiency can be as high as 87% (input: 48V output: 12V@2A)
- It has excellent reliability and circuit protection such as over current, short circuit, under voltage and surge
- PCB standard size: 39*38.2*11.6mm
- Input/Output: isolate 1500Vdc
- Class 4 IEEE802.3 PD
- High reliability: The design meets the 5 million hour average failure interval

Scope of application

- Video and VoIP Phone
- RFID Reader
- Multiband Access Point
- Surveillance camera
- Multiband Access Point

Describe

- The WC-PD25A120J-R1 PoE module is a traditional Category 5 and Category 6 twisted pair Ethernet power supply module based on the IEEE 802.3AT PoE standard
- Designed to extract power from power supply equipment (PSE) through conventional twisted pair cables over Category 5 and Category 6 Ethernet cables. The module input complies with the IEEE803.2AT signature recognition and classification standards.
- Pre configured as a Type 2, Level 4 device, allowing the module to obtain class 4 power from the PSE, with a rated output voltage of 12V. Efficient DC/DC converters can achieve an efficiency of about 87% and operate within a wide input voltage range, with low ripple and low noise output. The DC/DC converter also has built-in output overload and short circuit protection, and provides 1500Vdc (input/output) isolation barrier

Mechanical dimensions

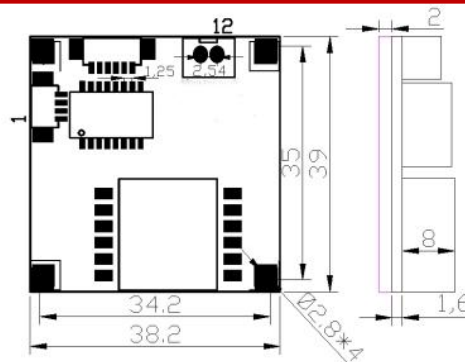

Unit: mm;

Unmarked tolerances: ±0.5

pin definition

Pin	Name	describe
1	TX+	Network signal output TX+
2	TX-	Network signal output TX-
3	RX+	Network signal output RX+
4	RX-	Network signal output RX-
5	4/5	Network cable access/Ethernet cable sequence 4/5
6	7/8	Network cable access/Ethernet cable sequence 7/8
7	TX+	TX+ Receive data+/Ethernet cable sequence (1),+48V power input terminal
8	TX-	TX - Receive data -/Ethernet cable sequence (2),+48V power input terminal
9	RX+	RX+ Receive data+/Ethernet cable sequence (3),-48V power input terminal
10	RX-	RX - Receive data -/Ethernet cable sequence (6),-48V power input terminal
11	Vout-	This pin is the module output negative pole
12	Vout+	This pin is the module output positive pole

Electrical Characteristics

Absolute maximum rating parameter

No	parameter	Symbol	MIN	MAX	Units
1	Input DC voltage	VCC	42	57	V
2	DC Voltage Surge 1ms	VSURGE	-0.6	80	V
3	ambient temperature	TS	-40	80	°C

- Exceeding the above rating may cause permanent damage to the product.Functional operations under these conditions are not recommended

Recommended working conditions

No	parameter	Symbol	MIN	TYP	MAX	Units
1	Input DC voltage	VIN	42	48	57	V
2	Low pressure input threshold	VLOCK	37	-	-	V
3	Ambient Temperature	TOP	-40	25	80	°C

- Applicable only to WC-PD30A120J-R1 maximum operating temperature

DC Characteristic

No	parameter	Symbol	MIN	TYP	MAX	Units	Test conditions
1	Standard Output Voltage	VDC	11.75	12.0	12.2	V	VIN=48v Tc: 25°C
2	Output Current (VIN=48V)	PWR	-	2	-	A	Wide voltage input 42-57V
3	Power adjustment rate	VLINE	-	0.1	-	%	@50% Load
4	Load Adjustment Rate	VLOAD	-	1	-	%	@VIN=48V
5	Ripple Output Noise	VRN	-	200	250	V	@Maximum Load
6	Minimum Load	RLOAD	10	-	-	A	
7	Short circuit duration	TSC	-	-	∞	%	
8	Efficiency (load 80%)	EFF	82	87	-	%	
9	Isolation Voltage (I/O)	VISO	-	-	1500	V	
10	temperature coefficient	Tc	-	0.02		A	Per °C
11	transient response	Ts	-	100	120	%	VIN=48V VOUT=max

- Typical number is 25 C, nominal voltage is 48V, for auxiliary design only
- Output ripple and noise can be reduced by an external filter, see the application instructions
- If operated under the specified minimum load, the module will emit sound noise, which may cause repeated hiccups in the PSE

Functional Description

input:

- The input terminal of WC-PD25A120J-R1 is not preset with "bridge reactor", so it is necessary to pay attention to the polarity of power supply core

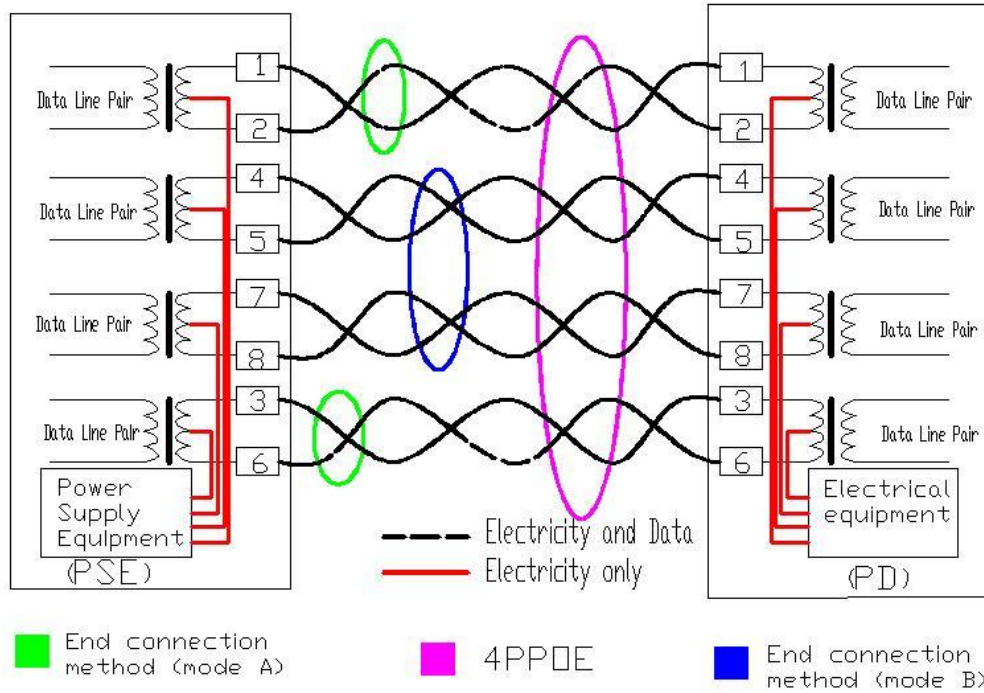

PD Power Supply Agreement

- When the module is connected to the cable, it will automatically provide the Power Device (PD) signature to the PSE when needed. The PSE recognizes that the PD is connected to that line and provides power.

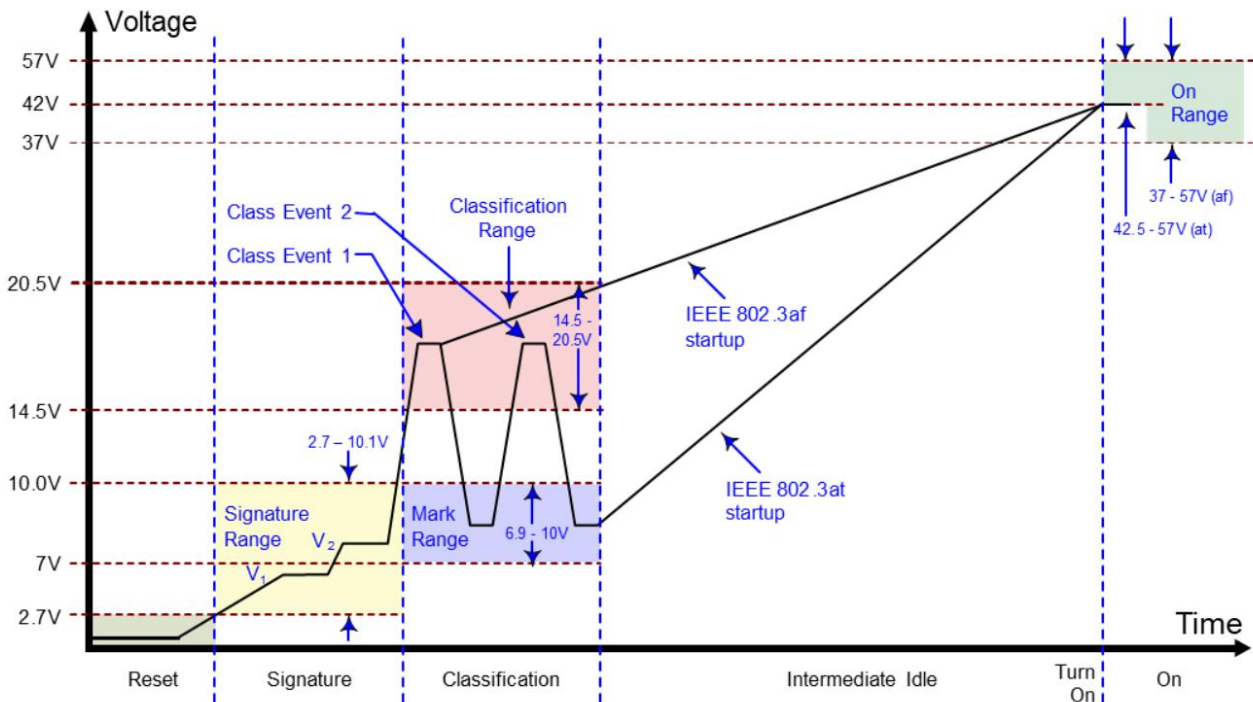

Power Classification:

- WC-PD25A120J-R1 adopts IEEE802.3at standard, with a default operating rated power of level 4 (30W)
- When using standard ultra six level network cables, under the condition of 30W at 10m, the rated power will gradually decrease with the length of the input conductor

Define criteria	Cable requirements	Grading parameters	Power Supply Characteristics
IEEE802.3at (PoE Plus)	CAT5 cable or CAT6 cable	Maximum power required for Class4 devices is 13W~25.5W	1. The DC voltage ranges from 42 to 57V, with a typical value of 48V. 2. Typical operating current is 10~600mA; typical output power: 25.5W. 3. Class4 rating supported by electrical equipment.
IEEE802.3bt (PoE++)	CAT5 cable or CAT6 cable	The maximum power required for level 5 equipment is 40W	1. DC voltage range 42 V to 57 V, typical value 52V. 2. Typical working current is 10 ~ 1300 mA; typical output power: 71W;
		The maximum power required for level 6 equipment is 51W	
		The maximum power required for level 7 equipment is 62W	
		The maximum power required for level 8 equipment is 71W	

Typical Connection Diagram

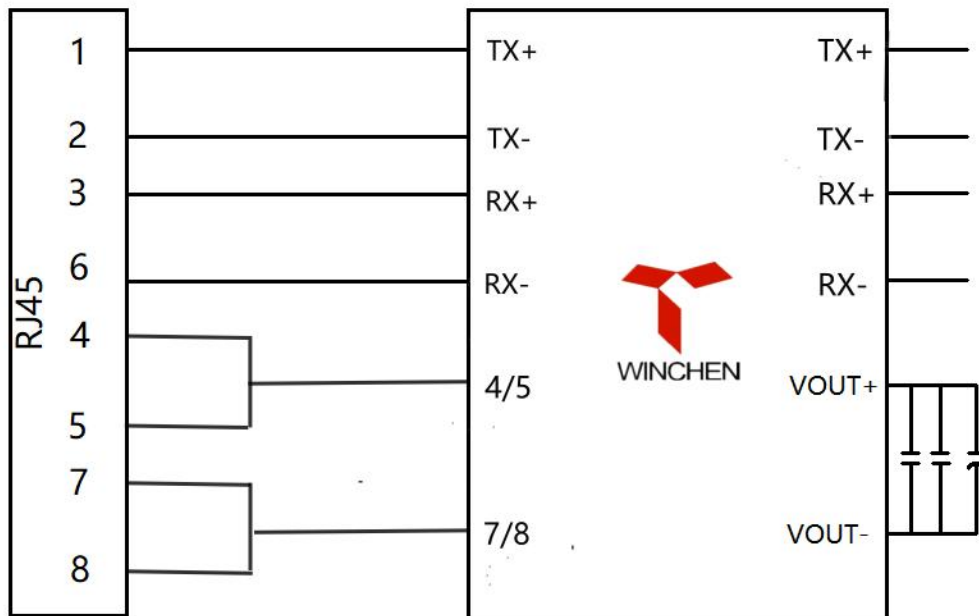

Typical applications

- This module is used in PSE network cable to convert electric energy to DC-DC to the required voltage of equipment without affecting data signal transmission. It conforms to IEEE 802.3at standard and is used by all equipment terminals

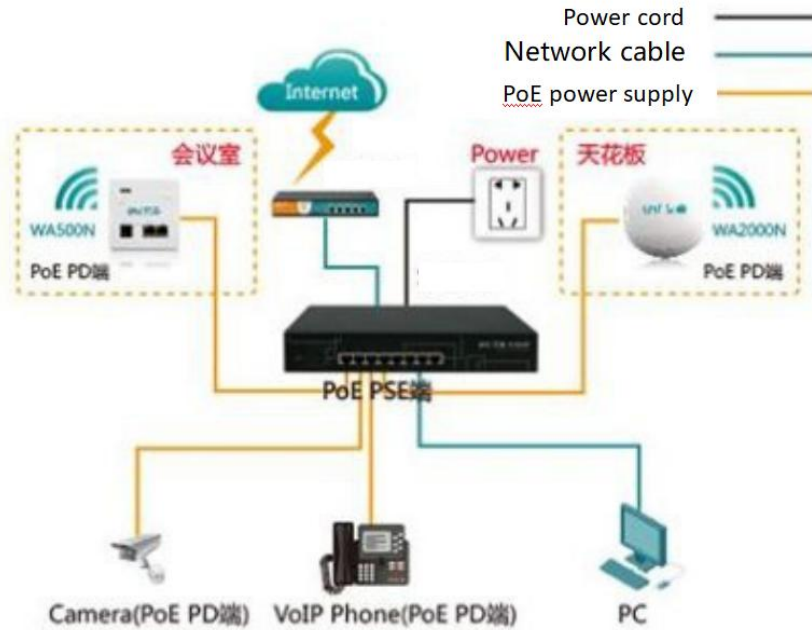

Test waveform diagram

Typical features: Output voltage=12V

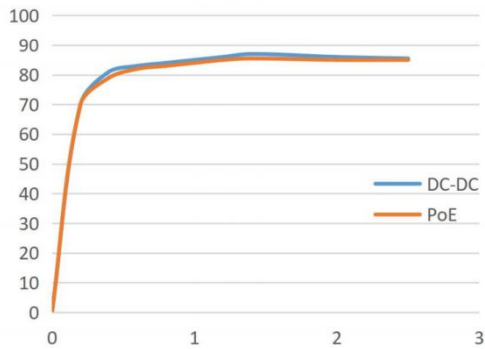

Efficiency (Vout = 12V)

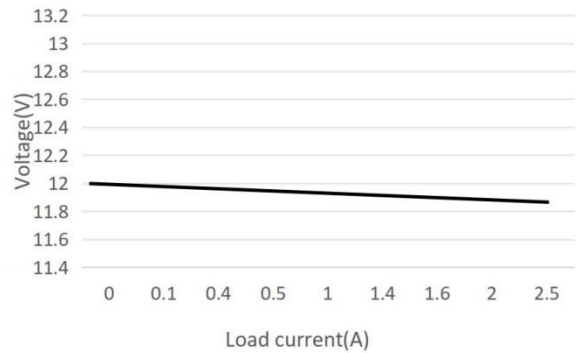

Output current voltage (input 48V)

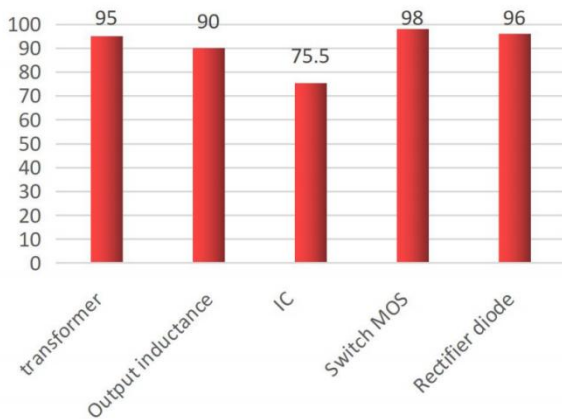

Maximum temperature of components

Conditions (ambient temperature: 27 °C; output power: 12V / 2A; frequency: 3H)

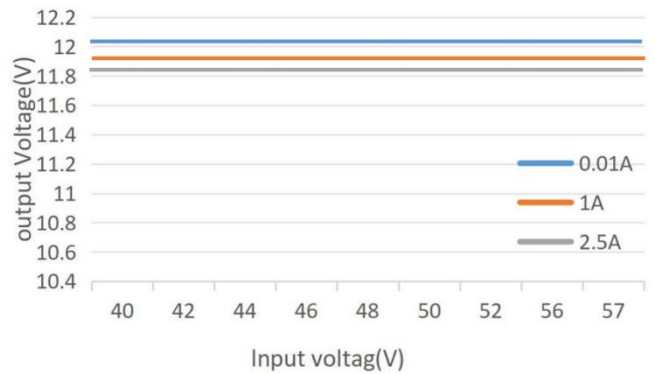

Input voltage & output voltage

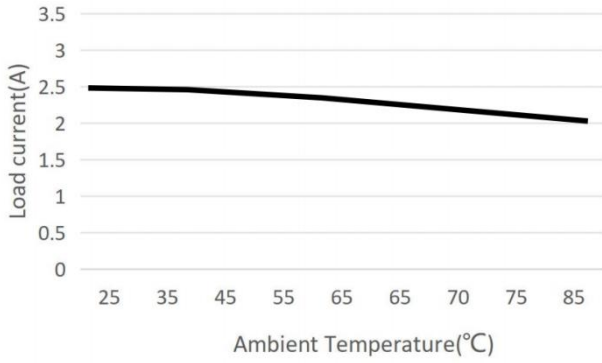

Derating

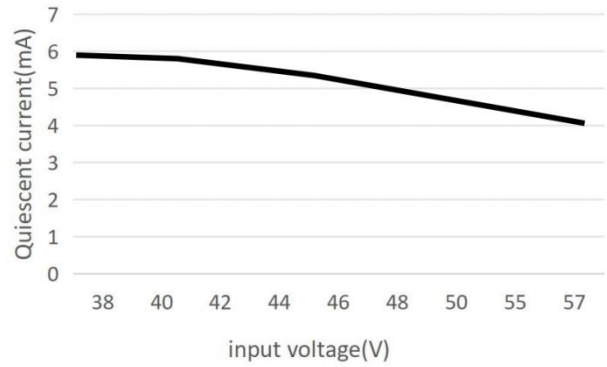

Quiescent current

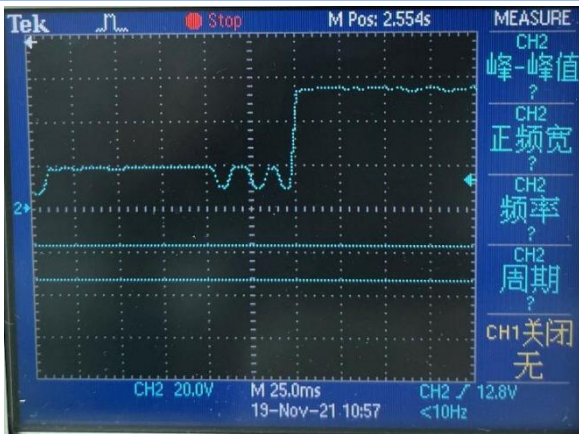

Power on protocol handshake



Output ripple (12V/2A)

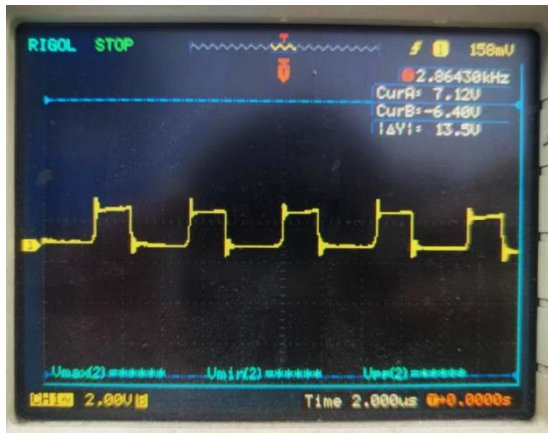

SW switch waveform

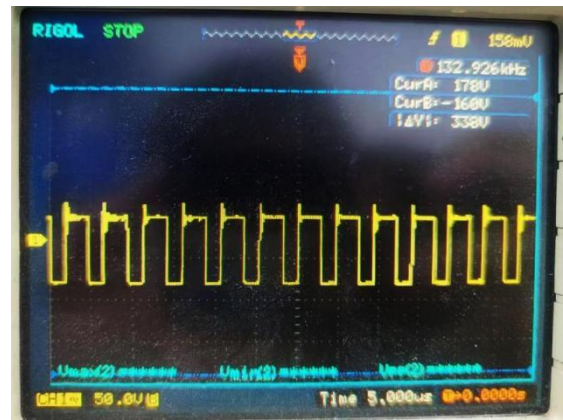

PWM

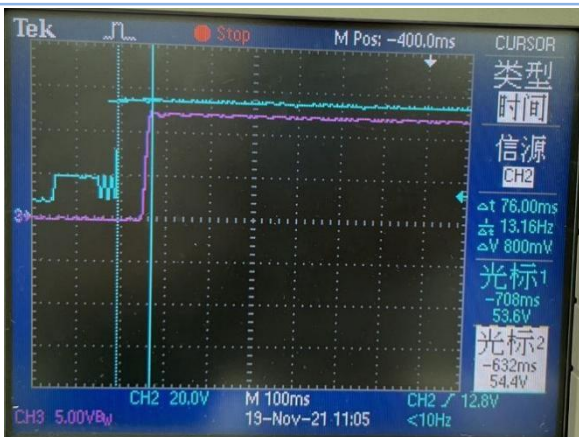

Power On

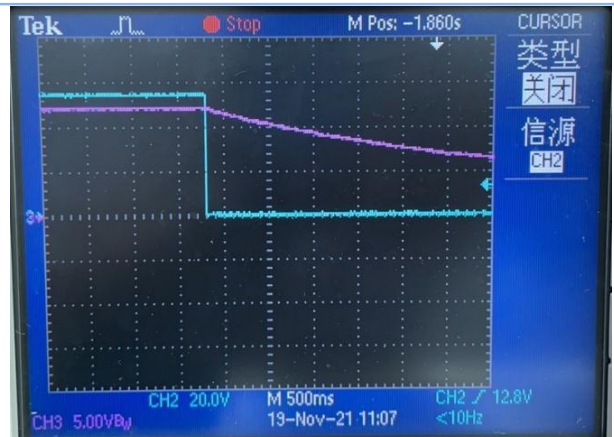

Power Down