

20W PD-5V

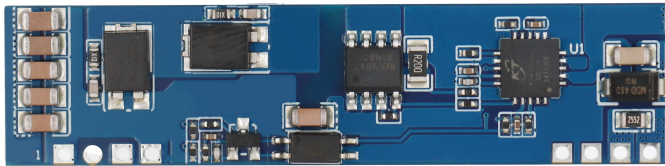

Product characteristics

- Compliance with IEEE802.3at standard(downward compatibility AF)
- 42V~57V wide operating voltage range
- Maximum output power up to 20W; Rated output: 5V/4A
- The output ripple is less than 200 mV
- Conversion efficiency can be as high as 86% (input: 48V output:5V@4A)
- Withovercurrent, short circuit, under voltage, surge andother excellent reliability and circuit protection
- PCBA standard size: 57.7*13.95*15.6mm
- Input/Output: isolate 1500Vdc
- Class 4 IEEE802.3 PD
- High reliability: The design meets the 5 million hour average failure interval

Scope of application

- Video and VoIP Phone
- RFID Reader
- Multiband Access Point
- Surveillance camera

Describe

- The WC-PD20C050E-R1 PoE module is a traditional Category 5 and 6 twisted pair Ethernet power supply module based on the IEEE 802.3AT PoE standard
- Designed to extract power from power supply equipment (PSE) through conventional twisted pair Category 5 and Category 6 Ethernet cables. Module inputs comply with IEEE803.2AT signature recognition and classification standards
- Pre configured as a Type 1, Level 3 device, allowing the module to obtain class 4 power from the PSE with a rated output voltage of 5V. Efficient DC/DC converters can achieve an efficiency of about 86% and operate within a wide input voltage range, with low ripple and low noise output. The DC/DC converter also has built-in output overload and short circuit protection, and provides 1500Vdc (input/output) isolation barrier

Mechanical dimensions

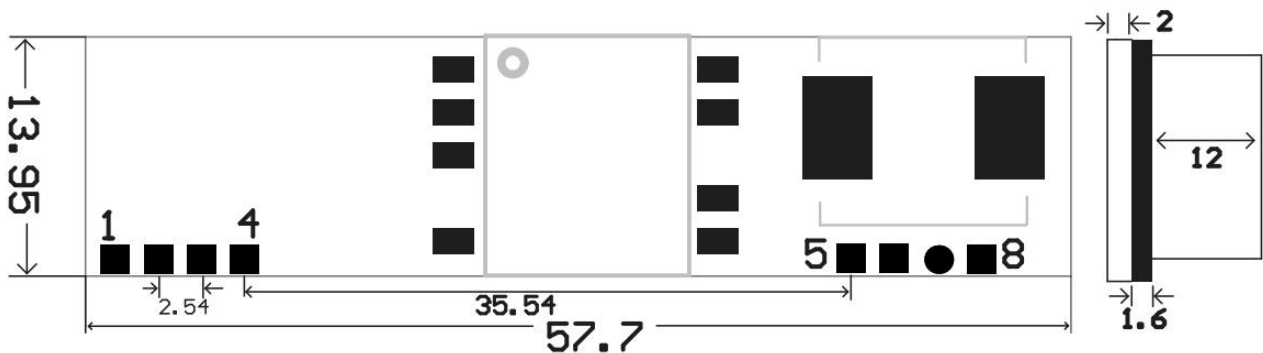

Unit: mm;

Unmarked tolerances: ±0.5

pin definition

Pin	Name	describe
1	VIN+	This pin is connected to the input negative (+) power supply using the "middle overlap method", so it needs to be connected to the center tap of the 4/5 network transformer to connect this pin. If the power supply adopts the "end crossing method", it is necessary to connect the center tap of the 1/2 network transformer to this pin
2	VIN-	This pin is connected to the input negative (-) power supply using the "middle overlap method", so it needs to be connected to the center tap of the 7/8 network transformer to connect this pin. If the power supply adopts the "end crossing method", it is necessary to connect the center tap of the 3/6 network transformer to this pin
3,4	NC	Reserve fixed welding needle
6	Vout+	This pin is the module output positive pole
5, 8	Vout-	This module output the negative power terminal
7	PGOOD	This pin is the module output negative pole

- Since there is no bridge stack access at the power supply input terminal, pay attention to the positive and negative polarity

Electrical Characteristics

Absolute maximum rating parameter

No	parameter	Symbol	MIN	MAX	Units
1	Input DC voltage	VCC	42	57	V
2	DC Voltage Surge 1ms	VSURGE	-0.6	80	V
3	ambient temperature	TS	-40	70	°C

- Exceeding the above rating may cause permanent damage to the product. Functional operations under these conditions are not recommended

Recommended working conditions

No	parameter	Symbol	MIN	TYP	MAX	Units
1	Input DC voltage	VIN	42	48	57	V
2	Low pressure input threshold	VLOCK	37	-	-	V
3	Ambient Temperature	TOP	-40	25	80	°C

- Applicable only to WC-PD20C050E-R1 maximum operating temperature

DC Characteristic

No	parameter	Symbol	MIN	TYP	MAX	Units	Test conditions
1	Standard Output Voltage	VDC	4.75	5	5.2	V	VIN=48v
2	Output Current (VIN=48V)	PWR	-	4	-	A	Wide voltage input 42-57V
3	Power adjustment rate	VLINE	-	0.1	-	%	@50% Load
4	Load Adjustment Rate	VLOAD	-	1	-	%	@VIN=48V
5	Ripple Output Noise	VRN	-	200	-	mVp-p	@Maximum Load
6	Minimum Load	RLOAD	10	-	-	mA	
7	Short circuit duration	TSC	-	-	∞	sec	
8	Efficiency (load 80%)	EFF	-	86	-	%	
9	Isolation Voltage (I/O)	VISO	-	-	1500	VPK	
10	temperature coefficient	Tc	-	0.02		%	Per °C
11	transient response	Ts	-	150	250	ms	VIN=48V VOUT=max

- Typical number is 25 C, nominal voltage is 48V, for auxiliary design only
- Output ripple and noise can be reduced by an external filter, see the application instructions
- If operated under the specified minimum load, the module will emit sound noise, which may cause repeated hiccups in the PSE

Functional Description

input:

- WC-PD20C050E-R1 input without bridge stacking, the user can select the connection mode as needed

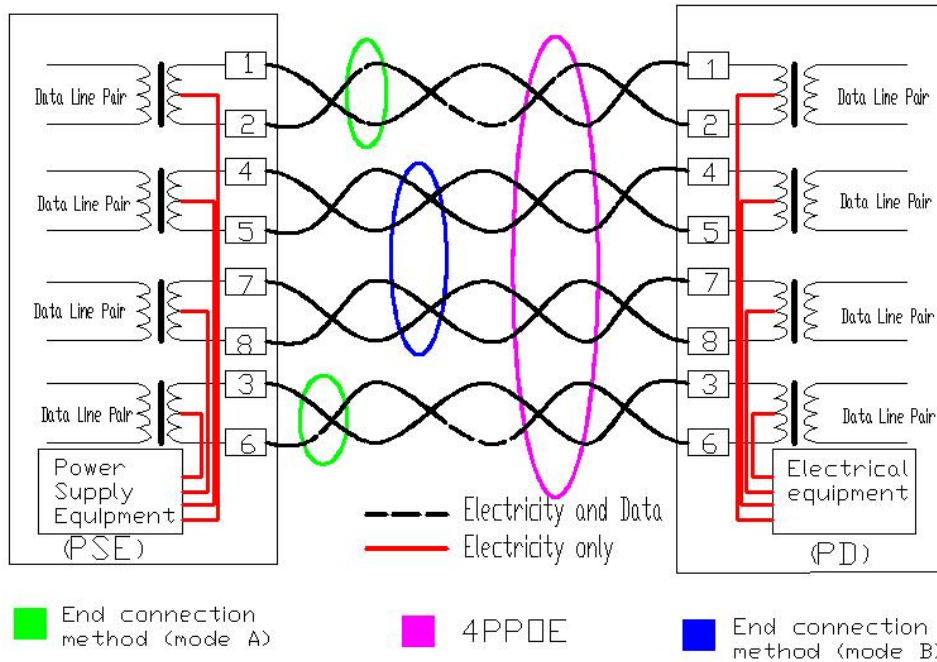

PD Power Supply Agreement

- When the module is connected to the cable, it will automatically provide the Power Device (PD) signature to the PSE when needed. The PSE recognizes that the PD is connected to that line and provides power.

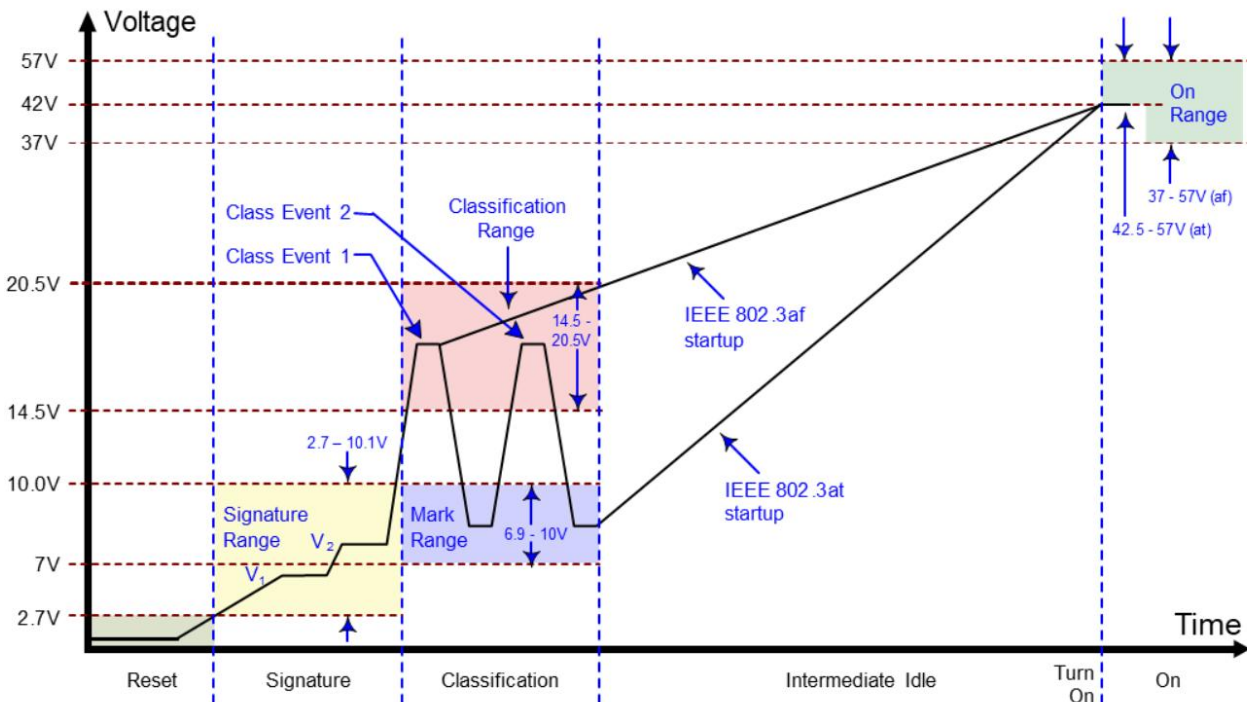

Power Classification:

- WC-PD20C050E-R1 adopts the IEEE802.3at standard, with a default rated power of level 4 (20W) for operation
- When using standard Category 6 Ethernet cables, under the condition of 30W at 10m, the rated power will gradually decrease with the length of the input conductor

Define criteria	Cable requirements	Grading parameters	Power Supply Characteristics
IEEE802.3at (PoE Plus)	CAT5 cable or CAT6 cable	Maximum power required for Class4 devices is 13W~25.5W	<ol style="list-style-type: none"> The DC voltage ranges from 42 to 57V, with a typical value of 48V Typical operating current is 10~600mA; typical output power: 25.5W Class4 rating supported by electrical equipment.
IEEE802.3af (PoE)	CAT5 cable	Maximum power required for Class0 devices is 0~12.95W	<ol style="list-style-type: none"> The DC voltage ranges from 38 to 57V, with a typical value of 48V Typical operating current is 10~350mA; typical output power: 15.4W The overload detection current is 350~500mA Provide 4 Class Power Requests for PD Devices ranging from 3.84 to 12.95W
		The maximum power required for Class1 devices is 0~3.84W	
		The maximum power required for Class2 devices is 3.85W~6.49W	
		The maximum power required for Class3 devices is 6.5W~12.95W	

Typical Connection Diagram

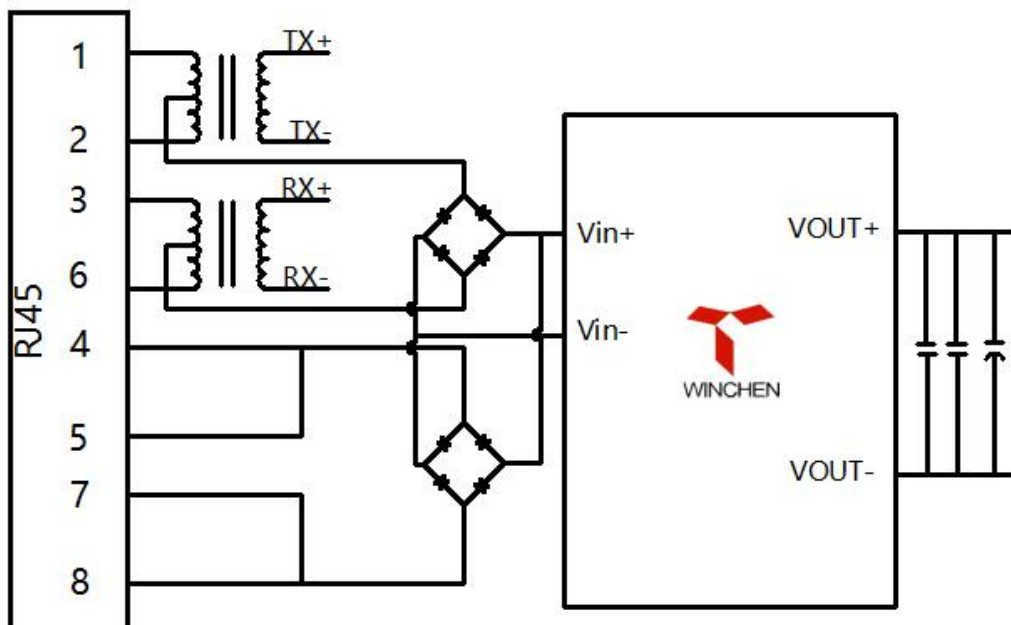

Typical applications

- This module is used in the PSE network cable to convert electrical energy into the voltage required for DC-DC to the device without affecting data signal transmission. Complies with IEEE802.3AT standard and is used by all device terminals.

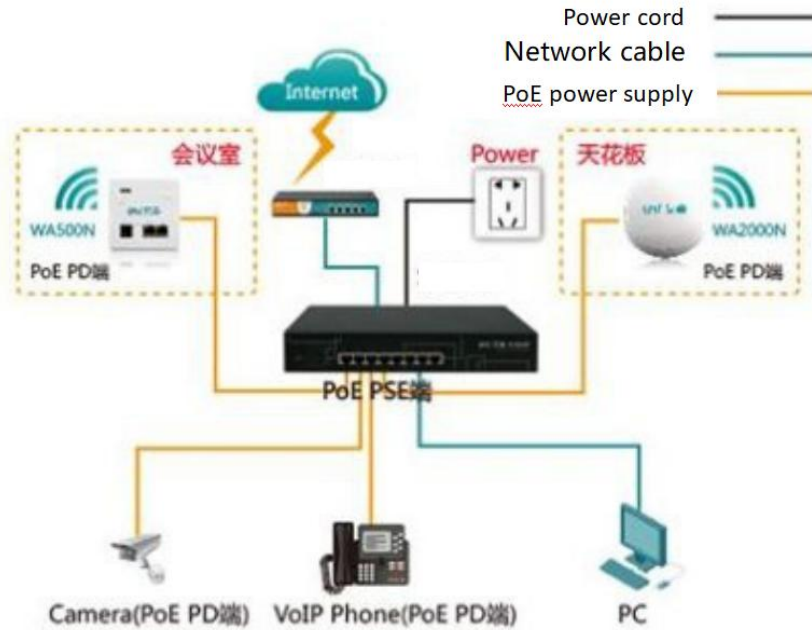

Test waveform diagram

Typical trait: Output voltage = 5V

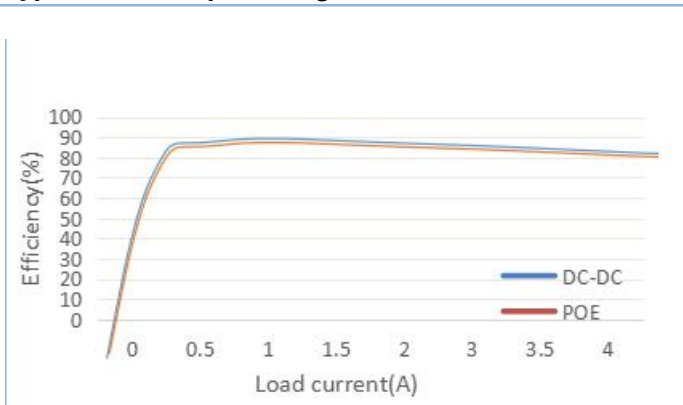

efficiency(Vout = 5V)

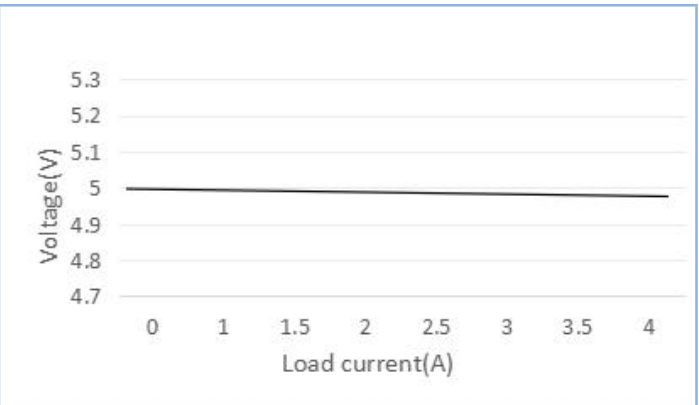

Output current voltage (input 48V)

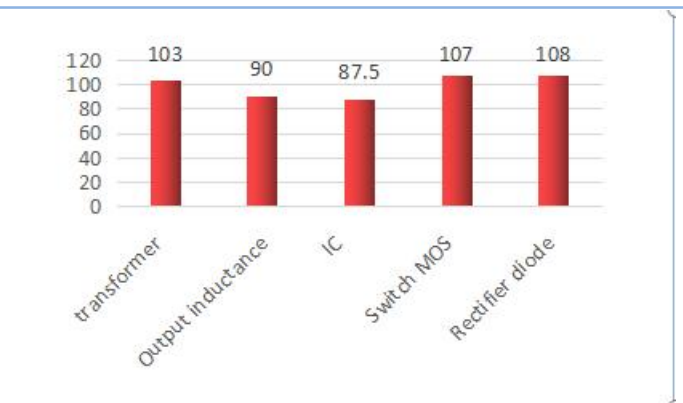

Maximum component temperature condition (ambient temperature: 27°C; output power: 5V /4A; time: 2H)

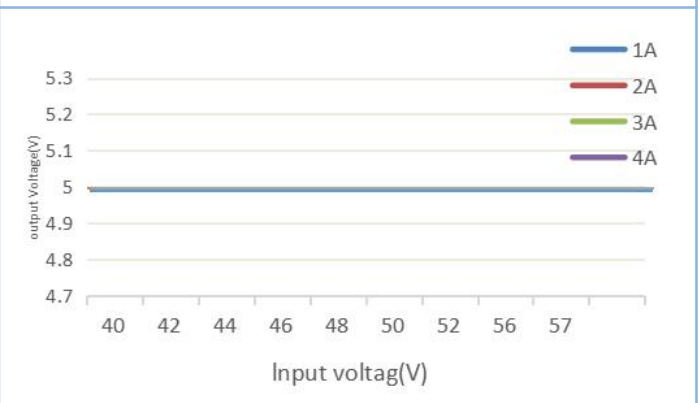

Input voltage & output voltage

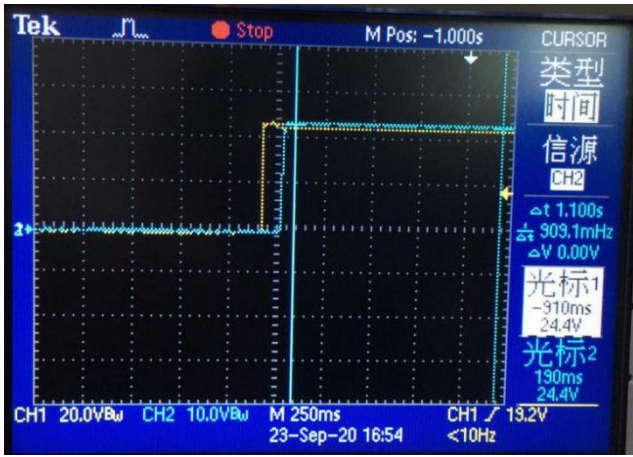

Power on



Power down

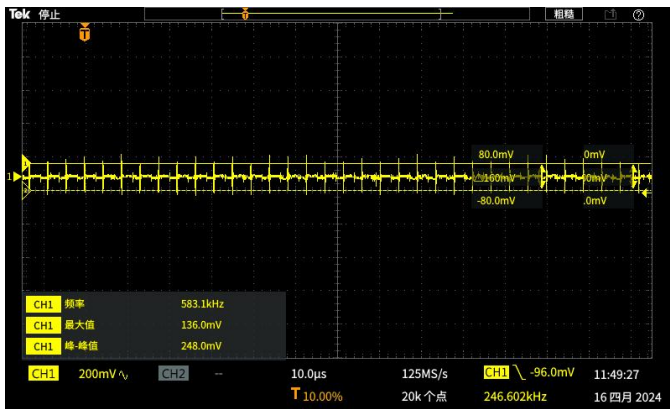

output ripple (5V / 4A)



PWM



SW switch waveform