

12W PD-12V

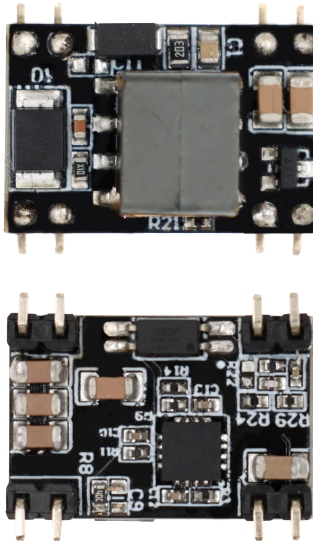

Product Characteristics

- Compliance with IEEE802.3af standard
- 39V~57V wide operating voltage range
- Maximum output power up to 12W; Rated output: 12V/1A
- The output ripple is less than 200 mV(Applied capacitance)
- Conversion efficiency can be as high as 86% (input: 48V output: 12V@1A)
- It has excellent reliability and circuit protection such as over current, short circuit, under voltage and surge
- PCB standard size: 21*14*13.2mm
- Input/Output: isolate 1500Vdc
- Class 3 IEEE802.3 PD
- High reliability: The design meets the 5 million hour average failure interval

Scope of Application

- Video and VoIP Phone
- RFID Reader
- Digital signage
- Multiband Access Point
- Surveillance camera

Describe

- The WC-PD13M120A PoE (Power over Ethernet) module is a traditional Category 5 and Category 6 twisted pair Ethernet power module based on the IEEE 802.3AF PoE standard
- Designed to extract power from power supply equipment (PSE) through conventional twisted pair Category 5 and Category 6 Ethernet cables. Module inputs comply with IEEE803.2AF signature recognition and classification standards
- Pre configured as a Type 1 Level 3 device, allowing the module to obtain class 3 power from the PSE with a rated output voltage of 12V. Efficient DC/DC converters can achieve an efficiency of about 86% and operate within a wide input voltage range, with low ripple and low noise output. The DC/DC converter also has built-in output overload and short circuit protection, and provides 1500Vdc (input/output) isolation barrier

Mechanical Dimensions

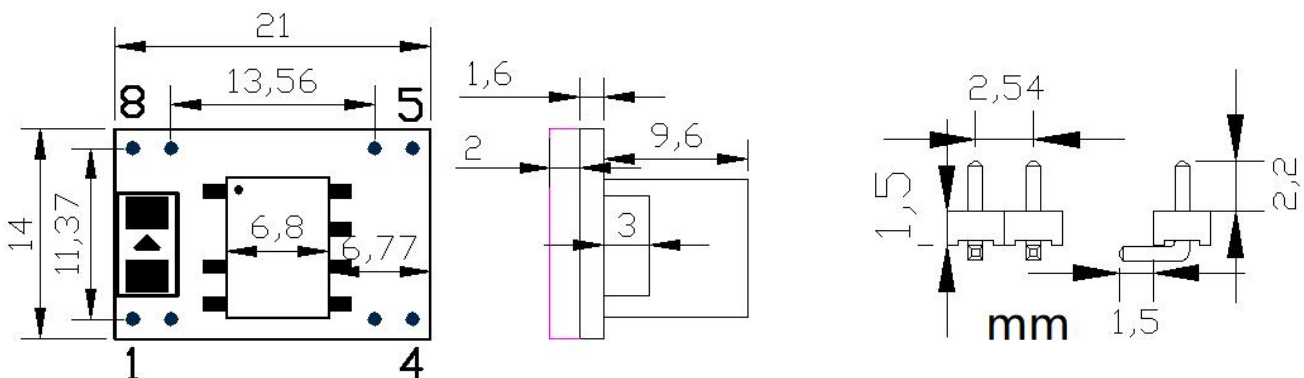

Unit: mm;

 Unmarked tolerances: ± 0.5

Pin Definition

Pin	Name	describe
1,2	Vout+	This pin is the module output positive pole
3,4	Vout-	This pin is the module output negative pole
5,6	Vin+	This pin is connected to the input negative (+) power supply using the "middle overlap method", so it needs to be connected to the center tap of the 4/5 network transformer to connect this pin. If the power supply adopts the "end crossing method", it is necessary to connect the center tap of the 1/2 network transformer to this pin
7,8	Vin-	This pin is connected to the input negative (-) power supply using the "middle overlap method", so it needs to be connected to the center tap of the 7/8 network transformer to connect this pin. If the power supply adopts the "end crossing method", it is necessary to connect the center tap of the 3/6 network transformer to this pin

- Since there is no bridge stack access at the power supply input terminal, pay attention to the positive and negative polarity!

Electrical Characteristics

Absolute maximum rating parameter

No	Parameter	Symbol	MIN	MAX	Unit
1	Input DC voltage	VCC	39	57	V
2	DC Voltage Surge 1ms	VSURGE	-0.6	80	V
3	ambient temperature	TS	-40	80	°C

- Exceeding the above rating may cause permanent damage to the product. Functional operations under these conditions are not recommended

Recommended working conditions

No	Parameter	Symbol	MIN	TYP	MAX	Unit
1	Input DC voltage	VIN	39	48	57	V
2	Low pressure input threshold	VLOCK	37	-	-	V
3	Ambient Temperature	TOP	-40	25	80	°C/60%RH

- Applicable only to WC-PD13M120A maximum operating temperature

DC Characteristic

No	Parameter	Symbol	MIN	TYP	MAX	Unit	Test conditions
1	Standard Output Voltage	VDC	11.75	12.0	12.2	V	VIN=48V Tc: 25°C
2	Output Current (VIN=48V)	PWR	-	1	-	A	Wide voltage input 39-57V
3	Power adjustment rate	VLINE	-	0.1	-	%	@50% Load
4	Load Adjustment Rate	VLOAD	-	1	-	%	@VIN=48V
5	Ripple Output Noise	VRN	-	200	250	mVp-p	@Maximum Load
6	Minimum Load	RLOAD	10	-	-	mA	
7	Short circuit duration	TSC	-	-	∞	sec	
8	Efficiency (load 80%)	EFF	82	86	-	%	
9	Isolation Voltage (I/O)	VISO	-	-	1500	VPK	
10	temperature coefficient	Tc	-	0.02		%	Per °C
11	transient response	Ts	-	200	300	ms	VIN=48V VOUT=max

- Typical number is 25 C, nominal voltage is 48V, for auxiliary design only
- Output ripple and noise can be reduced by an external filter, see the application instructions
- If operated under the specified minimum load, the module will emit sound noise, which may cause repeated hiccups in the PSE

Functional Description

Input:

- WC-PD13M120A There is no bridge stack at the input end. Ensure the input polarity and the user can choose the connection mode as needed

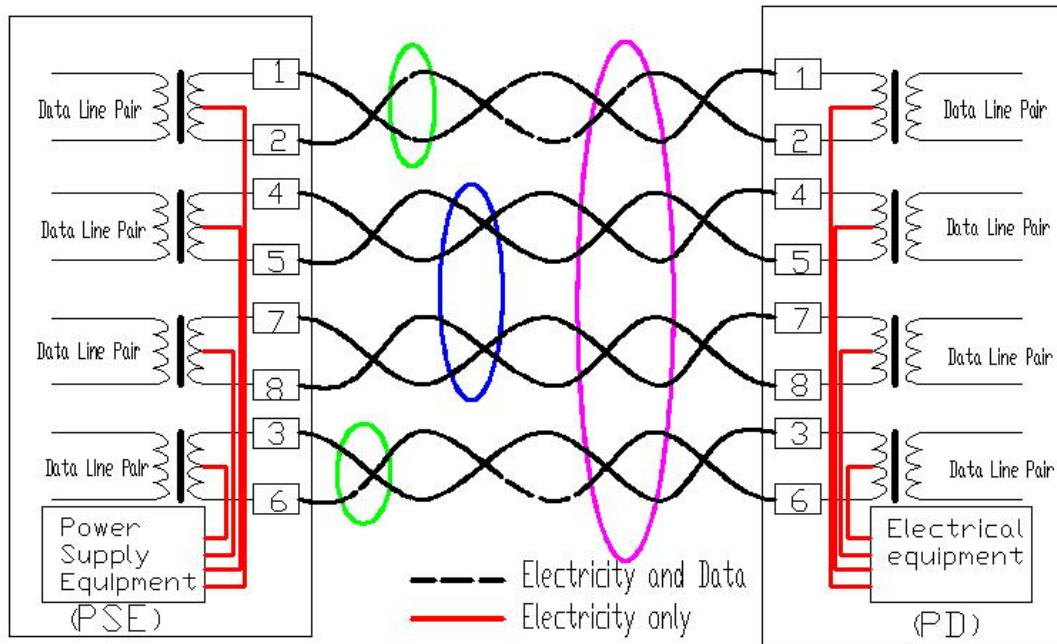

End connection method (mode A)

4PPoE

End connection method (mode B)

PD Power Supply Agreement

- When the module is connected to the cable, it will automatically provide the Power Device (PD) signature to the PSE when needed. The PSE recognizes that the PD is connected to that line and provides power

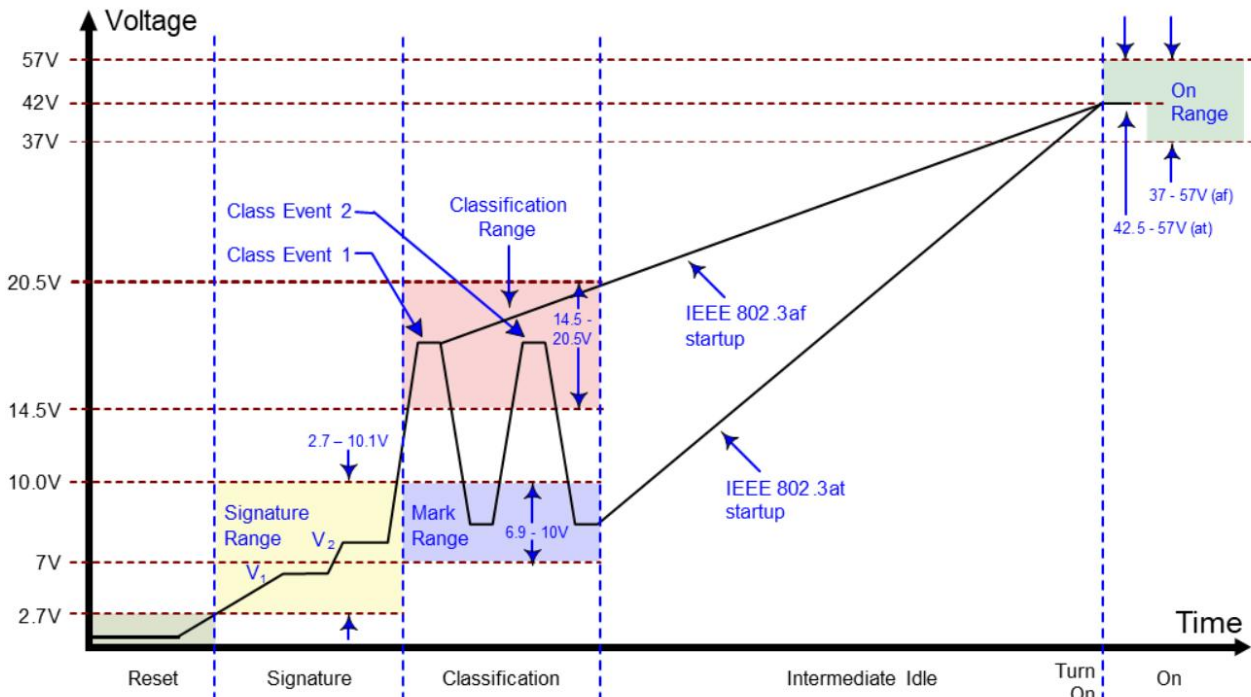

Power Classification:

➤ WC-PD13M120A uses IEEE802.3af standard and runs with Class 3 (12W) power rating by default

Define Criteria	Cable requirements	Grading parameters	Power Supply Characteristics
IEEE802.3at (PoE Plus)	CAT5 cable or CAT6 cable	Maximum power required for Class4 devices is 13W~25.5W	<ol style="list-style-type: none"> The DC voltage ranges from 42 to 57V, with a typical value of 48V Typical operating current is 10~600mA; typical output power: 25.5W Class4 rating supported by electrical equipment.
IEEE802.3af (PoE)	CAT5 cable	Maximum power required for Class0 devices is 0~12.95W	<ol style="list-style-type: none"> The DC voltage ranges from 38 to 57V, with a typical value of 48V Typical operating current is 10~350mA; typical output power: 15.4W The overload detection current is 350~500mA Provide 4 Class Power Requests for PD Devices ranging from 3.84 to 12.95W
		The maximum power required for Class1 devices is 0~3.84W	
		The maximum power required for Class2 devices is 3.85W~6.49W	
		The maximum power required for Class3 devices is 6.5W~12.95W	

Typical Connection Diagram

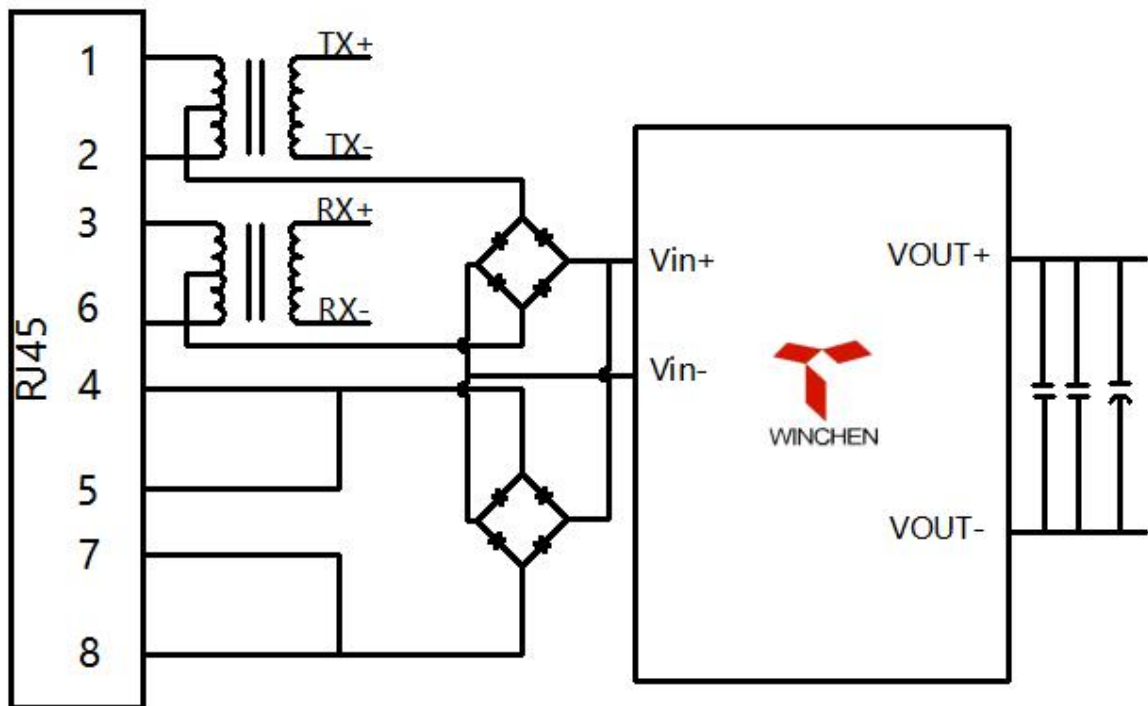

Typical Applications

- This module is used in PSE network cable to convert electric energy to DC-DC to the required voltage of equipment without affecting data signal transmission. It conforms to IEEE 802.3af standard and is used by all equipment terminals

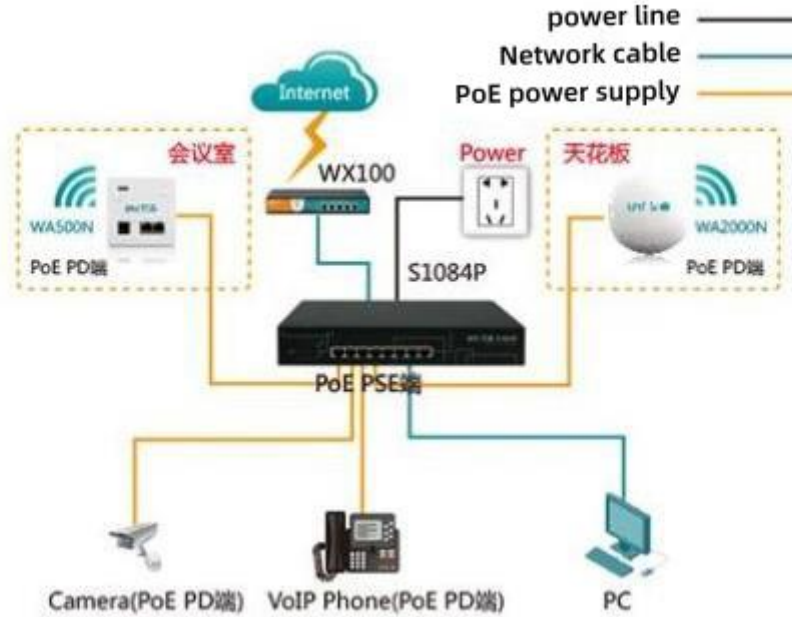

Test Waveform Diagram

Typical Features: Output Voltage=12V

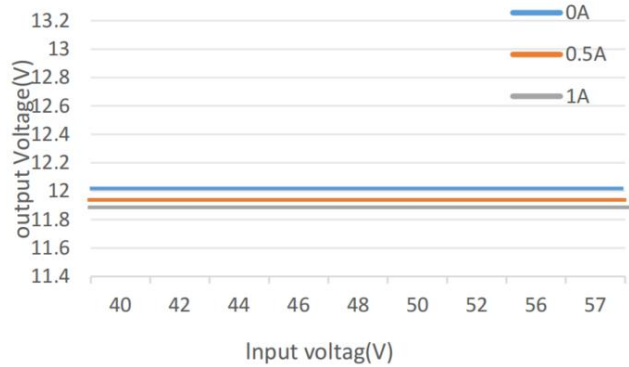
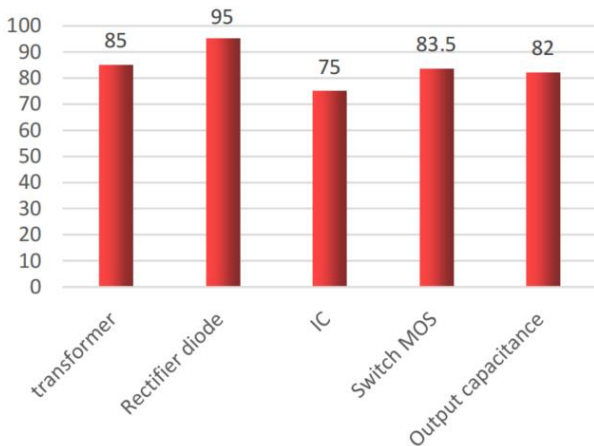
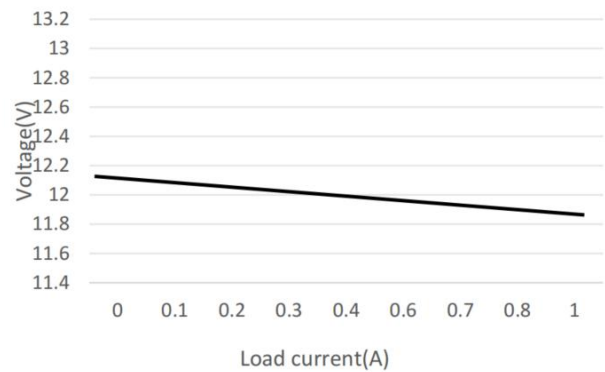
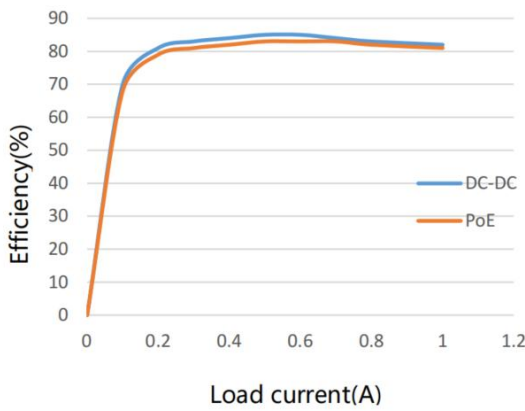

Maximum temperature of components
 Conditions (ambient temperature: 27 °C; output power: 12V / 1A; frequency: 3H)

Input voltage & output voltage

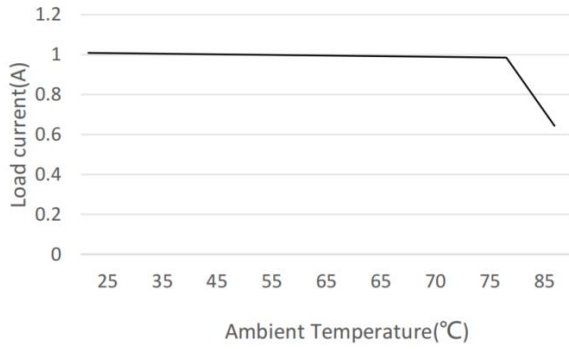

Derating

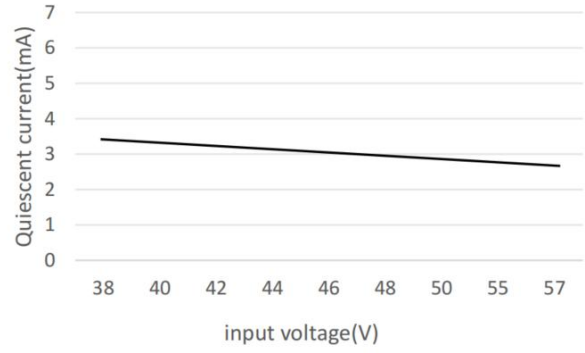

Quiescent current

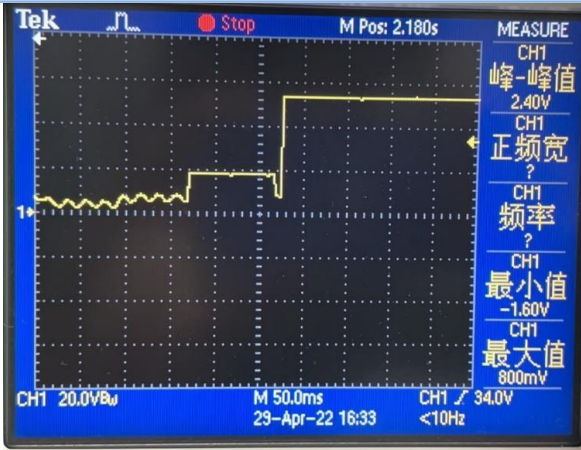

Power on protocol handshake

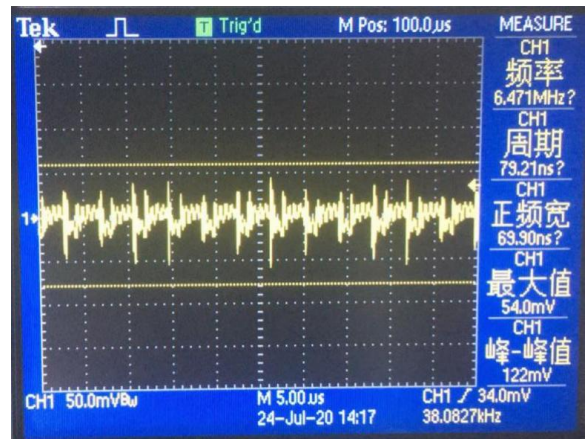

Output ripple (12V/1A)

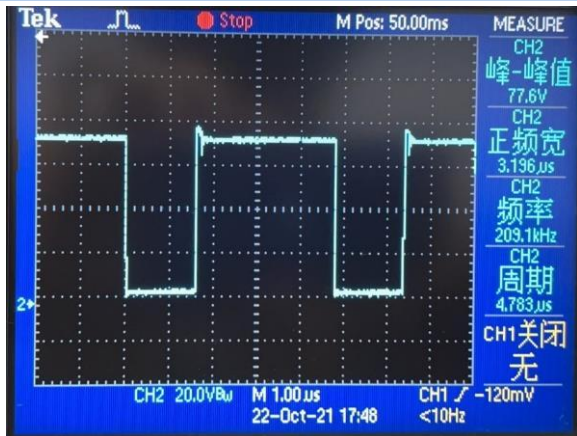

SW switch waveform

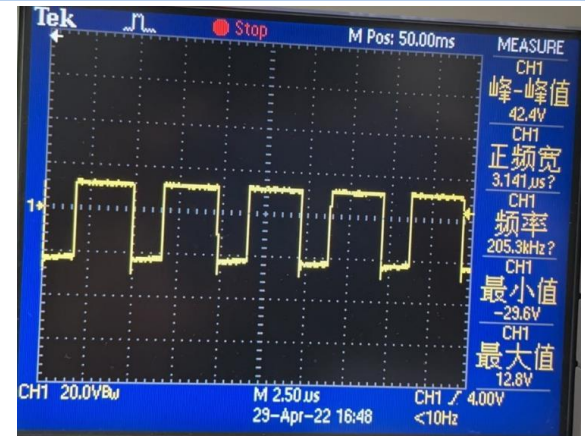

Output rectifier diode



Power On



Power Down