



SIM8970x_SIM8070

Hardware Design

LTE Module

SIMCom Wireless Solutions Limited

SIMCom Headquarters Building, Building 3, No. 289 Linhong Road, Changning District, Shanghai P.R. China

Tel: 86-21-31575100

support@simcom.com

www.simcom.com

Document Title:	SIM8970x_SIM8070 Hardware Design
Version:	V1.03
Date:	2022-04-10
Status:	Released

GENERAL NOTES

SIMCOM OFFERS THIS INFORMATION AS A SERVICE TO ITS CUSTOMERS, TO SUPPORT APPLICATION AND ENGINEERING EFFORTS THAT USE THE PRODUCTS DESIGNED BY SIMCOM. THE INFORMATION PROVIDED IS BASED UPON REQUIREMENTS SPECIFICALLY PROVIDED TO SIMCOM BY THE CUSTOMERS. SIMCOM HAS NOT UNDERTAKEN ANY INDEPENDENT SEARCH FOR ADDITIONAL RELEVANT INFORMATION, INCLUDING ANY INFORMATION THAT MAY BE IN THE CUSTOMER'S POSSESSION. FURTHERMORE, SYSTEM VALIDATION OF THIS PRODUCT DESIGNED BY SIMCOM WITHIN A LARGER ELECTRONIC SYSTEM REMAINS THE RESPONSIBILITY OF THE CUSTOMER OR THE CUSTOMER'S SYSTEM INTEGRATOR. ALL SPECIFICATIONS SUPPLIED HEREIN ARE SUBJECT TO CHANGE.

COPYRIGHT

THIS DOCUMENT CONTAINS PROPRIETARY TECHNICAL INFORMATION WHICH IS THE PROPERTY OF SIMCOM WIRELESS SOLUTIONS LIMITED COPYING, TO OTHERS AND USING THIS DOCUMENT, ARE FORBIDDEN WITHOUT EXPRESS AUTHORITY BY SIMCOM. OFFENDERS ARE LIABLE TO THE PAYMENT OF INDEMNIFICATIONS. ALL RIGHTS RESERVED BY SIMCOM IN THE PROPRIETARY TECHNICAL INFORMATION , INCLUDING BUT NOT LIMITED TO REGISTRATION GRANTING OF A PATENT , A UTILITY MODEL OR DESIGN. ALL SPECIFICATION SUPPLIED HEREIN ARE SUBJECT TO CHANGE WITHOUT NOTICE AT ANY TIME.

SIMCom Wireless Solutions Limited

SIMCom Headquarters Building, Building 3, No. 289 Linhong Road, Changning District, Shanghai P.R. China

Tel: +86 21 31575100

Email: simcom@simcom.com

For more information, please visit:

https://www.simcom.com/module/smart_modules.html

For technical support, or to report documentation errors, please visit:

<https://www.simcom.com/ask/> or email to: support@simcom.com

Copyright © 2021 SIMCom Wireless Solutions Limited All Rights Reserved.

Version History

Date	Version	Description of change	Author
2021-09-20	1.01	Original	Junfeng Zhang
2022-01-20	1.02	Second Edition	Junfeng Zhang
2022-04-10	1.03	Third Edition	Junfeng Zhang

SIMCom
Confidential

Contents

1	Introduction.....	11
1.1	Product Outline.....	11
1.2	Functional Overview.....	13
2	Package Information.....	16
2.1	Hardware Block Diagram.....	16
2.2	Pin Assignment Overview.....	17
2.3	PIN Description.....	18
3	Interface Applications.....	38
3.1	Power Supply.....	38
3.1.1	Pin Overview.....	38
3.1.2	Power Supply Stability Design.....	39
3.2	Power On & Power Off.....	40
3.2.1	Power On.....	40
3.2.2	Power On Sequence.....	41
3.2.3	Power Off.....	42
3.3	Power On & Power Off.....	42
3.4	Power Output.....	44
3.5	Charging and Battery Management.....	45
3.6	USB Interface.....	47
3.6.1	Micro-USB Interface and Type-C Interface.....	48
3.6.2	Micro-USB Interface and Type-C Interface Feature.....	50
3.7	UART/SPI/I2C/I2S Interface.....	52
3.7.1	UART/SPI/I2C Interface Multiplexing.....	52
3.7.2	UART Voltage Level Switch Circuit.....	53
3.7.3	SPI Interface.....	54
3.7.4	I2C Interface.....	55
3.7.5	I2S Interface.....	55
3.8	SD Card Interface.....	56
3.9	TP Interface.....	57
3.10	LCD Interface.....	57
3.11	Camera Interface.....	58
3.11.1	CPHY & DPHY Interface of the Cameras.....	59
3.11.2	DPHY Applications.....	60
3.12	Audio Interface.....	61
3.12.1	Microphone Interface.....	61
3.12.2	Headphone Interface.....	62
3.12.3	Speaker Interface.....	63

3.12.4	Handset Interface.....	64
3.13	UIM Card Interface.....	64
3.14	ADC.....	65
3.15	Sensor Interface.....	66
3.16	Motor Interface.....	67
3.17	LED Interface.....	67
3.18	Flash LED Interface.....	68
3.19	Forced Emergency Download Interface.....	68
4	WIFI & BT.....	70
4.1	WIFI Outline.....	70
4.1.1	WIFI Feature.....	70
4.2	BT Outline.....	72
5	GNSS.....	73
5.1	GNSS Outline.....	73
5.2	GNSS RF & Antenna Design Guideline.....	73
6	Antenna Interface.....	74
6.1	MAIN Antenna & DRX Antenna.....	74
6.1.1	Operating Frequency Band.....	74
6.1.2	RF Reference Design.....	76
6.2	WIFI/BT Antenna Interface.....	77
6.3	GNSS Antenna Interface.....	78
6.3.1	GNSS Passive Antenna Reference Design.....	78
6.3.2	GNSS Active Antenna Reference Design.....	79
6.4	RF Signals PCB Wiring Guideline.....	80
6.5	Antenna Installation.....	82
6.5.1	GNSS Passive Antenna Reference Design.....	82
6.5.2	RF Connector.....	83
7	PCB Wiring.....	84
7.1	Stack Selection.....	84
7.2	PCB Routing Guidelines.....	84
7.2.1	Antenna.....	84
7.2.2	Power Supply & Ground.....	85
7.2.3	UIM Card.....	85
7.2.4	MIPI.....	85
7.2.5	USB.....	87
7.2.6	SD Card.....	88
7.2.7	Audio.....	88
8	Electrical & Reliability.....	90
8.1	Absolute Maximum Value.....	90
8.2	Temperature Range.....	90
8.3	Operating Voltage.....	90
8.4	Digital Interface Feature.....	91
8.5	Current Consumption (VBAT = 3.9V).....	92

8.6	Electrostatic Protection.....	93
8.7	RF Transmission Power.....	93
8.8	Conducted Receiving Sensitivity.....	94
9	Manufacture & Production.....	97
9.1	Top- and Bottom-View of the Module.....	97
9.2	Mechanical Dimensional Size.....	98
9.3	Recommend Physical Outline Drawing.....	99
9.4	Recommend Physical SMT Stencil Drawing.....	100
9.5	Recommend Temperature Curve of Reflow Furnace.....	101
9.6	Moisture Sensitivity Level (MSL).....	102
9.7	Baking Requirements.....	102
9.8	Packaging.....	103
10	Recommend Devices.....	106
11	Appendix.....	110
11.1	Relative Documents.....	110
11.2	Terms & Abbreviations.....	111
11.3	Safety Caution.....	113

SIMCom
Confidential

Table Index

Table 1: SIM8970x series module.....	11
Table 2: General features.....	13
Table 3: Defination of the I/O Parameters.....	18
Table 4: Pin Properties.....	18
Table 5: Pin Description.....	27
Table 6: Recommended TVS Diode.....	40
Table 7: KPD_PWR_N Features.....	41
Table 8: VRTC Features.....	44
Table 9: Power Definition.....	44
Table 10: Comparison of the Charge Protocol.....	45
Table 11: The Battery's Pin Definition.....	46
Table 12: The Interface Configuration of the Micro-USB or the Type-C.....	48
Table 13: DP and USB3.1 Type-C Compatible Pin Definition.....	50
Table 14: UART/SPI/I2C Interface Multiplexing Feature.....	52
Table 15: Recommend SPI Interface.....	54
Table 16: Recommend I2C Interface.....	55
Table 17: Recommend I2S Interface.....	55
Table 18: DPHY & CPHY PIN Definition.....	59
Table 19: Headphone Output Feature.....	63
Table 20: Audio PA Feature.....	63
Table 21: Handset Output Feature.....	64
Table 22: ADC Interface Feature.....	65
Table 23: Sensor Interface Feature.....	66
Table 24: WIFI Emitter Feature.....	70
Table 25: WIFI Receiver Feature.....	71
Table 26: BT RF Feature.....	72
Table 27: GNSS Feature.....	73
Table 28: MAIN Antenna & DRX Antenna Feature.....	74
Table 29: Operating Frequency Band.....	74
Table 30: WIFI/BT Antenna Feature.....	77
Table 31: WIFI/BT Operating Frequency Band.....	77
Table 32: GNSS Antenna Feature.....	78
Table 33: GNSS Operating Frequency Band.....	78
Table 34: Two Layers PCB Microstrip-slot Line Structure Impedance Control Feature.....	80
Table 35: Two Layers PCB Coplanar Waveguide-slot Line Structure Impedance Control Feature.....	81
Table 36: Antenna Installation Requirements.....	82
Table 37: MIPI Lane Wiring Difference.....	85
Table 38: SIM8970CE USB Wiring Length.....	87
Table 39: SIM8970EU USB Wiring Length.....	87
Table 40: SD Card Wiring Length.....	88

Table 41: Absolute Maximum Value.....	90
Table 42: Temperature Range.....	90
Table 43: Operating Voltage.....	90
Table 44: SDC2 Interface Electrical Feature (1.8V).....	91
Table 45: SDC2 Interface Electrical Feature (2.96V).....	91
Table 46: UIM Card Interface Electrical Feature (VREG_UIM = 1.8V or 2.95V).....	91
Table 47: GPIO Electrical Feature.....	91
Table 48: Current Consumption.....	92
Table 49: ESD Feature (Temperature: 25°C, Humidity: 45%).....	93
Table 50: Conducted Output Power.....	93
Table 51: Conducted Receiving Sensitivity.....	94
Table 52: LTE Reference Sensitivity 3GPP Standard (QPSK).....	95
Table 53: Moisture Sensitivity Level Classification.....	102
Table 54: Baking Requirements.....	102
Table 55: Module Tray Size.....	104
Table 56: Small Carton Size.....	104
Table 57: Big Carton Size.....	105
Table 58: Recommend Cameras Lists.....	106
Table 59: Recommend Screen.....	106
Table 60: Recommend Gyroscope Sensors Lists.....	107
Table 61: Recommend Geomagnetism Sensors Lists.....	107
Table 62: Recommend Light Sensors Lists.....	108
Table 63: Recommend Pressure Sensors Lists.....	109
Table 64: Relative Documents.....	110
Table 65: Terms & Abbreviations.....	111
Table 66: Safety Caution.....	113

Figure Index

Figure 1: Module Block Diagram.....	16
Figure 2: Pin Assignment Overview.....	17
Figure 3: LDO Power Supply Reference Design.....	38
Figure 4: DC-DC Power Supply Reference Design.....	39
Figure 5: DC-DC Power Supply Reference Design.....	39
Figure 6: Power On/Off Design with a Key.....	40
Figure 7: Power On/Off Design with an OC Gate.....	41
Figure 8: Power On/Off Design with an OC Gate.....	41
Figure 9: External Capacitor Power Supply for RTC.....	43
Figure 10: Non Rechargeable Battery Power Supply for RTC.....	43
Figure 11: Rechargeable Battery Power Supply for RTC.....	43
Figure 12: Battery Connection Reference Design.....	47
Figure 13: USB Type-C Connection Reference Design.....	49
Figure 14: USB Micro-USB Connection Reference Design.....	50
Figure 15: USB Type-C with DP Function Connection Reference Design.....	51
Figure 16: UART Voltage Level Switch Reference Design.....	53
Figure 17: TX Voltage Level Switch Reference Design.....	54
Figure 18: RX Voltage Level Switch Reference Design.....	54
Figure 19: SD Card Reference Design.....	56
Figure 20: TP Interface Reference Design.....	57
Figure 21: LCD Interface & the Backlight Reference Design.....	58
Figure 22: CPHY & DPHY Interface Applications.....	59
Figure 23: Three sets of MIPI-CSI Interface Applications.....	61
Figure 24: ECM Type Microphone Reference Design.....	61
Figure 25: MEMS Type Microphone Reference Design.....	61
Figure 26: Digital Microphone Reference Design.....	62
Figure 27: Headphone Reference Design.....	62
Figure 28: Speaker Reference Design.....	64
Figure 29: Handset Reference Design.....	64
Figure 30: UIM Card Interface Reference Design.....	65
Figure 31: Motor Interface Reference Design.....	67
Figure 32: RGB Interface Reference Design.....	68
Figure 33: Flash LED Interface Reference Design.....	68
Figure 34: Emergency Download Interface Reference Design.....	69
Figure 35: MAIN Antenna Reference Design.....	76
Figure 36: DRX Antenna Reference Design.....	76
Figure 37: WIFI/BT Antenna Reference Design.....	77
Figure 38: GNSS Passive Antenna Reference Design.....	79
Figure 39: GNSS Active Antenna Reference Design.....	79
Figure 40: Two Layers PCB Microstrip-slot Line Structure.....	80

Figure 41: Two Layers PCB Coplanar Waveguide-slot Line Structure.....	81
Figure 42: Four Layers PCB Coplanar Waveguide-slot Line Structure (Reference Layer Three).....	81
Figure 43: Four Layers PCB Coplanar Waveguide-slot Line Structure (Reference Layer Four).....	81
Figure 44: Hirose U.FL-R-SMT Connector's Size and Package.....	83
Figure 45: Top- and Bottom-View of the Module.....	97
Figure 46: Three-Dimensional Size (Unit: mm).....	98
Figure 47: Recommend Physical Outline Drawing (Unit: mm).....	99
Figure 48: Recommend Physical SMT Stencil Drawing (Unit: mm).....	100
Figure 49: Recommend Temperature Curve of Reflow Furnace.....	101
Figure 50: Packaging Diagram.....	103
Figure 51: Module Tray Size.....	104
Figure 52: Small Carton Size.....	104
Figure 53: Big Carton Size.....	105

SIMCom
Confidential

1 Introduction

SIM8970 module is a smart module newly released by SIMCom Wireless Solutions Co., Ltd. This module has the Android operating system, and the customers could use it for the development of their hardware devices.

This document introduces the hardware interfaces of the SIM8970 module. The users could quickly understand the definition of the interfaces, the electrical performance, and the die size of the module. Notice that SIM8970x series modules support different radio frequency (RF) range, different memory capacity, and different software version, etc. Please consult the local sales for more detailed information if needed.

1.1 Product Outline

SIM8970x series module is a 4G Android smart module developing by the platform of Qualcomm QCM6125. QCM6125 is an 8-Core customized 64-Bit ARM V-8 compatible application processor (Qualcomm® Kryo™ 260 CPU) adopting 11nm FinFET production process. It's high performance 4-Core basic frequency is up to 2.0GHz, and low power consumption 4-Core is up to 1.8GHz. SIM8970x series module has abundant multi-media functions, including the 4K@30 fps video codec, the 2520*1080 single displaying screen, four MIPI cameras, and the multi-channel analog- and digital-audio input and output. SIM8970x series module supports multiple communication modes, including the GSM/GPRS/EDGE, the WCDMA/HSPA+, the LTE-FDD, and the LTE-TDD. It also supports the WiFi 802.11 a/b/g/n/ac, and the BT5.X short range communication. For the satellite positioning system, SIM8970x series module supports the GPS, the GLONASS, the BEIDOU, and the Galileo. In conclusion, SIM8970x series module is a highly integrated product, which is widely applying to intelligent terminal devices in the field of the Internet of Things(IOT).

Table 1 shows the frequency bands differences working on the SIM8970x series module.

Table 1: SIM8970x series module

		SIM8970CE	SIM8970EU	SIM8970NA	SIM8070
General Configuration					
CPU Frequency		2.0GHz	2.0GHz	2.0GHz	2.0GHz
Memory	RAM	4GB	4GB	4GB	4GB
	ROM	64GB	64GB	64GB	64GB
Standard & Frequency					
GSM	GSM850				

	EGSM900	✓	✓		
	DCS1800	✓	✓		
	PCS1900				
WCDMA	B1	✓	✓		
	B2			✓	
	B4			✓	
	B5		✓	✓	
	B8	✓	✓		
FDD-LTE	B1	✓	✓		
	B2			✓	
	B3	✓	✓		
	B4			✓	
	B5	✓	✓	✓	
	B7		✓	✓	
	B8	✓	✓		
	B12			✓	
	B13			✓	
	B14			✓	
	B17			✓	
	B18				
	B19				
	B20		✓		
	B25			✓	
	B26			✓	
	B28A			✓	
B28B			✓		
B66				✓	
B71				✓	
TDD-LTE	B34	✓			
	B38	✓	✓		
	B39	✓			
	B40	✓	✓		
	B41	✓	✓	✓	
WLAN	802.11a/b/g/n/ac	✓	✓	✓	✓
BT	BT5.X	✓	✓	✓	✓
GNSS	GPS	✓	✓	✓	
	GLONASS	✓	✓	✓	
	BEIDOU	✓	✓	✓	
	Galileo				

1.2 Functional Overview

Table 2: General features

Feature	Description
Processor	<p>Customized 64-bit ARM V-8 compatible application processor (Qualcomm® Kryo™ 260 CPU)</p> <p>High Performance 4-Core frequency up to 2.0GHz, 1MB L2</p> <p>Low power consumption 4-Core frequency up to 1.8GHz, 512KB L2</p>
Memory	<p>LPDDR4X RAM, (2 × 16 Bit)BUS, Highest working frequency 1804MHz</p> <p>Built-in eMMC 5.1 Flash,</p> <p>Refer to the Table 1 for memory capacity,</p> <p>Default configuration: 64GB eMMC + 4GB LPDDR4,</p> <p>Selectable configuration: 64GB eMMC+6GB LPDDR4</p>
SD	<p>SDC2 external interface supports SD3.0 TF card (Maximum 256G), hot-join support</p>
Operation System	<p>Support Android 10.1</p>
System Upgrade	<p>Upgrade via USB interface, support forced download</p>
Power Supply	<p>Voltage range: 3.4V~4.4V, support single-cell lithium battery power supply.</p>
Charge	<p>Internal integrated PMI632 charging management chip, support QC2.0/QC3.0</p>
Display	<p>Support double screen asynchronous display.</p> <p>One 4-Lane MIPI_DSI interface, the highest resolution is 2520*1080, 60fps.</p> <p>DP1.4 over USB Type-C, the highest resolution is 1920*1200@60Hz.</p>
Camera	<p>MIPI combination DPHY 1.2 / CPHY 1.0 can be configured as 4/4/4 or 4/4/2/1</p> <p>D-PHY: 2.5Gbps/Channel, C-PHY: ~10Gbps(3.42Gbps/Channel)</p> <p>Dual 14-bit ISP, 16 MP + 16MP</p> <p>Single ISP: 16 MP 30 ZSL, Dual ISP: 25 MP 30 ZSL</p>
Video Codec	<p>Coding: 4k30 10-Bit HEVC, 4K30: H264/VP8</p> <p>Decoding: 4K30 8-Bit H.264/VP8, 4K30 10-Bit HEVC/VP9, 1080p60 MPEG-2</p> <p>Wireless display(Coding & Decoding): 4K30 decode & 1080p30 encode</p>
Audio	<p>3-Channel Digital Audio Interface I2S: Support Master- and Slave-Mode</p> <p>3-Channel Analog Audio Input</p> <p>Master Microphone: Differential Input, Built-in Bias</p> <p>Headphone Microphone: Single-ended Input, Built-in Bias</p> <p>Denoise Microphone: Differential Input, Built-in Bias</p> <p>4-Channel Digital Microphone Input</p> <p>4-Channel Analog Audio Output</p> <p>Headphone: Class AB Amplifier Stereo Output</p> <p>Handset: Class AB Amplifier Differential Output</p> <p>LINEOUT: Class AB Amplifier Differential Output</p> <p>Speaker: Class D Amplifier Differential Output</p>
Audio Codec	<p>MP3, AAC, He-AAC v1, v2, WMA 9/Pro, Dolby AC-3, eAC-3, DTS-HD, FLAC, APE, ALAC, AIFF, and EVS</p>

Speech Codec	EVRC, EVRC-B, EVRC-WB, G.711, G.729A/AB, GSM-FR, GSM-EFR, GSM-HR, AMR-NB, AMR-WB, AMR-eAMR, AMR-BeAMR
USB	Support USB 3.1 with DP interface, support USB2.0 Support USB Type-C Interface, Support MICRO-USB Interface USB1 support OTG.
UART	Support up to 6 Serial Ports A 2-Wire Serial Port for Debug Four 4-Wire Serial Ports support hardware flow control, High-speed up to 4Mbps.
I2C	Support up to ten I2C for touch screen, camera, sensor and other peripherals
SPI	Support up to four SPI interfaces, support master mode, the highest rate 50MHz
UIM Card	Support Dual Card Dual Standby: 1.8V/2.95V Dual Voltage Adaptive
Power Level	Class 4 (33dBm±2dB) for EGSM850 Class 4 (33dBm±2dB) for EGSM900 Class 1 (30dBm±2dB) for DCS1800 Class 1 (30dBm±2dB) for PCS1900 Class E2 (27dBm±3dB) for EGSM850 8-PSK Class E2 (27dBm±3dB) for EGSM900 8-PSK Class E2 (26dBm±3dB) for DCS1800 8-PSK Class E2 (26dBm±3dB) for PCS1900 8-PSK Class 3 (24dBm+1/-3dB) for WCDMA bands Class 3 (23dBm±2dB) for LTE-FDD bands Class 3 (23dBm±2dB) for LTE-TDD bands
LTE Features	Support 3GPP R10 CAT4 FDD and TDD Support 1.4 to 20 MHz RF Bandwidth Support Downstream 2x2 MIMO FDD: the maximum 150Mbps(DL) / the maximum 50Mbps(UL) TDD: the maximum 150Mbps(DL) / the maximum 35Mbps(UL)
UMTS Features	Support 3GPP R8 DC-HSDPA/HSPA+/HSDPA/HSUPA/WCDMA Support 16-QAM, 64-QAM and QPSK modulation DC-HSDPA: maximum 42Mbps(DL) HSUPA: maximum 5.76Mbps(UL) WCDMA: maximum 384Kbps(DL) / maximum 384bps(UL)
GSM Features	R99: CSD: 9.6Kbps, 14.4Kbps GPRS: Support GPRS Multi-Slot Level 33(Default 33) Coding format: CS-1, CS-2, CS-3, and CS-4 Maximum 85.6Kbps(UL) / Maximum 107Kbps(DL) EDGE: Support EDGE Multi-Slot Level 33(Default 33) Support GMSK and 8-PSK modulation and coding Methods Downlink Coding Format: CS 1-4 and MCS 1-9 Uplink Coding Format: CS 1-4 and MCS 1-9

	The maximum 236.8Kbps(UL) / The maximum 296Kbps(DL)
WLAN Features	2.4G/5G Dual Frequency Range, Support 802.11a/b/g/n/ac, Maximum 433Mbps Support Wake-on-WLAN(WoWLAN) Support ad-hoc Mode WAPI supports SMS4 Hardware Encryption Support AP Mode Support Wi-Fi Direct
BT Features	BT2.1+EDR /3.0 /4.2 LE/5.x
Satellite Positioning	GPS /GLONASS /BEIDOU/Galileo
Temperature	Operation Temperature: -35°C~ +75°C Extend Operation Temperature: -40°C ~ +85°C [1] Storage Temperature: -40°C~ +90°C
Physical Size	Size: 44.1(±0.2)*45.6(±0.2)*2.8(±0.2)mm Weight: 13.6g

NOTE

SIM8970x series module works normally within the extend operation temperature range, but if the testing procedures fully accord with 3GPP standard could not be guaranteed.

2 Package Information

2.1 Hardware Block Diagram

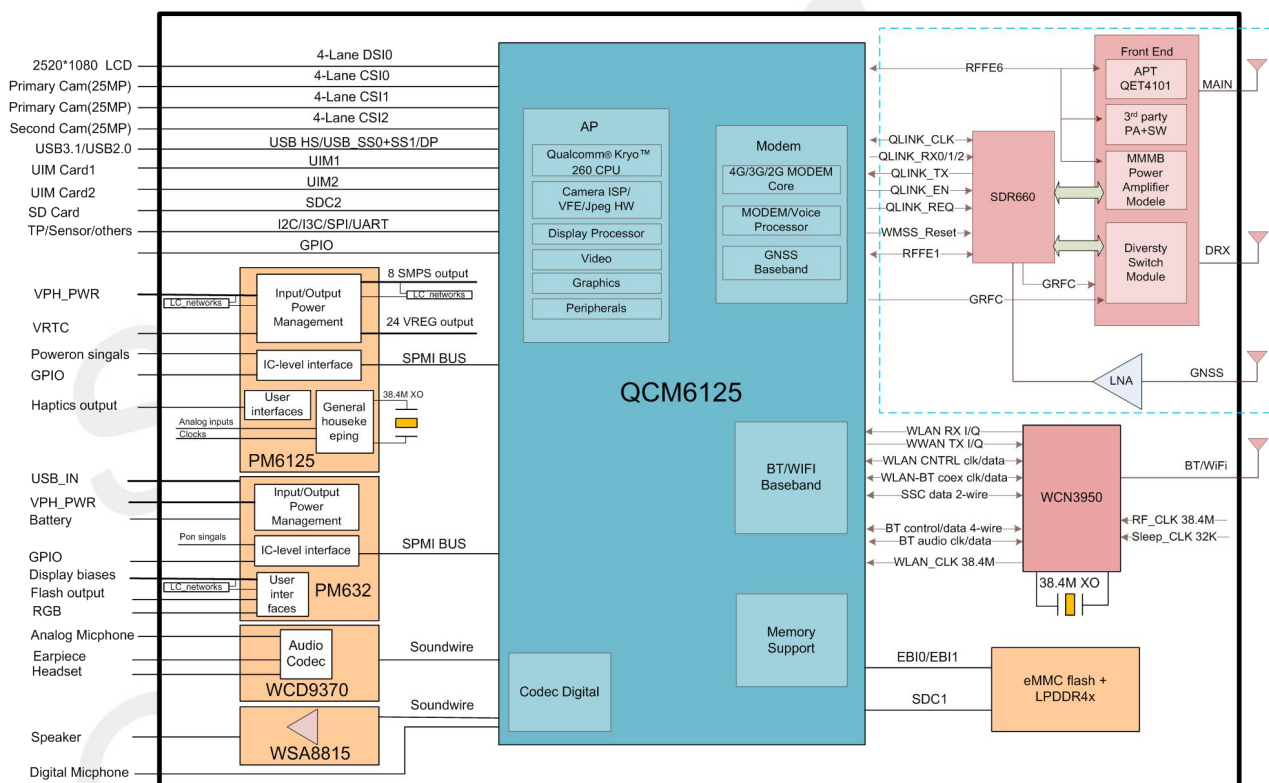

Figure 1: Module Block Diagram

2.2 Pin Assignment Overview

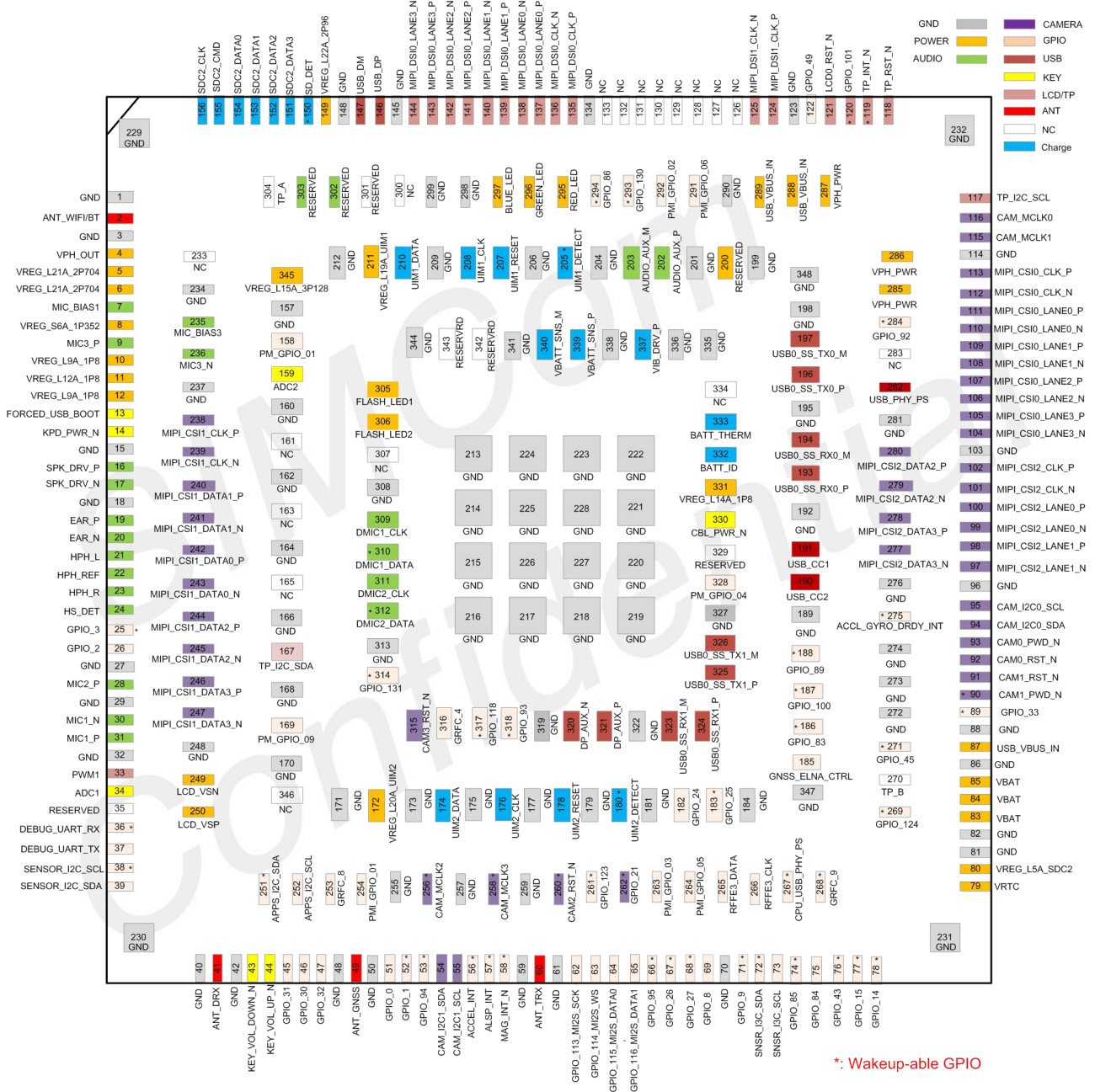

Figure 2: Pin Assignment Overview

*: Wakeup-able GPIO

2.3 PIN Description

Table 3: Defination of the I/O Parameters

Symble	Description
PIN Properties	
PI	Power Input
PO	Power Output
AI	Analog Input
AO	Analog Output
DI	Digital Input
DO	Digital Output
Digital Interface Pull Up and Pull Down	
NP	No Pull Up or No Pull Down
PU	Pull Up
PD	Pull Down

Table 4: Pin Properties

PIN Num	PIN Name	Voltage Range	QCM6125 PIN	Reset Status	Wakeup Interrupt	Note
1	GND					
2	ANT-WIFI/BT					
3	GND					
4	VPH_PWR	3.3-4.4V				
5	VREG_L21A_2P704	2.704V				
6	VREG_L21A_2P704	2.704V				
7	MIC_BIAS1	1.8V				1.0~2.85V
8	VREG_S6A_1P352	1.352V				
9	MIC3_P					
10	VREG_L9A_1P8	1.8V				
11	VREG_L12A_1P8	1.8V				
12	VREG_L9A_1P8	1.8V				
13	FORCED_USB_BOOT	1.8V	GPIO_99	B-PD	√	
14	KPD_PWR_N	1.8V				
15	GND					
16	SPKR_OUT_P					

17	SPKR_OUT_N				
18	GND				
19	EAR_P				
20	EAR_N				
21	HPH_L				
22	HPH_REF				
23	HPH_R				
24	HS_DET				
25	GPIO_3	1.8V	GPIO_3	B-PD	√
26	GPIO_2	1.8V	GPIO_2	B-PD	
27	GND				
28	MIC2_P				
29	GND				
30	MIC1_N				
31	MIC1_P				
32	GND				
33	PWM1		PM6125_GPIO_08		
34	ADC1	0~ 1.875V	PM6125_GPIO_07		
35	RESERVED				
36	DEBUG_UART_RX	1.8V	GPIO_17	DI	√
37	DEBUG_UART_TX	1.8V	GPIO_16	DO	
38	SENSOR_I2C_SCL	1.8V	GPIO_29	B-PD	√
39	SENSOR_I2C_SDA	1.8V	GPIO_28	B-PD	
40	GND				
41	ANT_DRX				
42	GND				
43	KEY_VOL_DOWN_N	1.8V		I-PU	
44	KEY_VOL_UP_N	1.8V	PM6125_GPIO_05	I-PU	√
45	GPIO_31	1.8V	GPIO_31	B-PD	
46	GPIO_30	1.8V	GPIO_30	B-PD	
47	GPIO_32	1.8V	GPIO_32	B-PD	
48	GND				
49	ANT_GNSS				
50	GND				
51	GPIO_0	1.8V	GPIO_0	B-PD	
52	GPIO_1	1.8V	GPIO_1	B-PD	√
53	GPIO_94	1.8V	GPIO_94	B-PD	√
54	CCI_I2C_SDA1	1.8V	GPIO_39	B-PD	
55	CCI_I2C_SCL1	1.8V	GPIO_40	B-PD	

56	ACCEL_INT	1.8V	GPIO_81	B-PD	√	
57	ALSP_INT_N	1.8V	GPIO_91	B-PD	√	
58	MAG_INT_N	1.8V	GPIO_82	B-PD	√	
59	GND					
60	ANT_TRX					
61	GND					
62	GPIO_113_PRI_MI2S_SCK	1.8V	GPIO_113	B-PD		
63	GPIO_114_PRI_MI2S_WS	1.8V	GPIO_114	B-PD		
64	GPIO_115_PRI_MI2S_DATA0	1.8V	GPIO_115	B-PD		
65	GPIO_116_PRI_MI2S_DATA1	1.8V	GPIO_116	B-PD		
66	GPIO_95	1.8V	GPIO_95	B-PD	√	
67	GPIO_26	1.8V	GPIO_26	B-PD	√	
68	GPIO_27	1.8V	GPIO_27	B-PD	√	
69	GPIO_8	1.8V	GPIO_8	B-PD		
70	GND					
71	GPIO_9	1.8V	GPIO_9	B-PD	√	
72	SNSR_I3C_SDA	1.8V	GPIO_22	B-PD	√	
73	SNSR_I3C_SCL	1.8V	GPIO_23	B-PD		
74	GPIO_85	1.8V	GPIO_85	B-PD	√	
75	GPIO_84	1.8V	GPIO_84	B-PD		
76	GPIO_43	1.8V	GPIO_43	B-PD	√	
77	GPIO_15	1.8V	GPIO_15	B-PD	√	
78	GPIO_14	1.8V	GPIO_14	B-PD	√	
79	VRTC	3.0V				2.0-3.25V
80	VREG_L5A_SDC2	2.85V				
81	GND					
82	GND					
83	VBAT	3.4~4.75V				
84	VBAT	3.4~4.75V				
85	VBAT	3.4~4.75V				
86	GND					
87	VBUS_USB_IN	5V~9V				
88	GND					
89	GPIO_33	1.8V	GPIO_33	B-PD	√	
90	CAM1_PWD_N	1.8V	GPIO_47	B-PD	√	
91	CAM1_RST_N	1.8V	GPIO_46	B-PD		
92	CAM0_RST_N	1.8V	GPIO_48	B-PD		
93	CAM0_PWD_N	1.8V	GPIO_52	B-PD		

94	CAM_I2C0_SDA	1.8V	GPIO_37	B-PD	
95	CAM_I2C0_SCL	1.8V	GPIO_38	B-PD	
96	GND				
97	MIPI_CSI2_LANE1_N				
98	MIPI_CSI2_LANE1_P				
99	MIPI_CSI2_LANE0_N				
100	MIPI_CSI2_LANE0_P				
101	MIPI_CSI2_CLK_N				
102	MIPI_CSI2_CLK_P				
103	GND				
104	MIPI_CSI0_LANE3_N				
105	MIPI_CSI0_LANE3_P				
106	MIPI_CSI0_LANE2_N				
107	MIPI_CSI0_LANE2_P				
108	MIPI_CSI0_LANE1_N				
109	MIPI_CSI0_LANE1_P				
110	MIPI_CSI0_LANE0_N				
111	MIPI_CSI0_LANE0_P				
112	MIPI_CSI0_CLK_N				
113	MIPI_CSI0_CLK_P				
114	GND				
115	CAM_MCLK1	1.8V	GPIO_35	B-PD	
116	CAM_MCLK0	1.8V	GPIO_34	B-PD	
117	GPIO_7_TP_I2C_SCL	1.8V	GPIO_7	B-PD	
118	TP_RST_N	1.8V	GPIO_87	B-PD	
119	TP_INT_N	1.8V	GPIO_88	B-PD	√
120	GPIO_101	1.8V	GPIO_101	B-PD	√
121	LCD0_RST_N	1.8V	GPIO_90	B-PD	
122	GPIO_49	1.8V	GPIO_49	B-PD	
123	GND				
124	MIPI_DSI1_CLK_P				
125	MIPI_DSI1_CLK_N				
126	NC				
127	NC				
128	NC				
129	NC				
130	NC				
131	NC				
132	NC				
133	NC				
134	GND				

135	MIPI_DSI0_CLK_P				
136	MIPI_DSI0_CLK_N				
137	MIPI_DSI0_LANE0_P				
138	MIPI_DSI0_LANE0_N				
139	MIPI_DSI0_LANE1_P				
140	MIPI_DSI0_LANE1_N				
141	MIPI_DSI0_LANE2_P				
142	MIPI_DSI0_LANE2_N				
143	MIPI_DSI0_LANE3_P				
144	MIPI_DSI0_LANE3_N				
145	GND				
146	USB_DP				
147	USB_DM				
148	GND				
149	VREG_L22A_2P96	2.96V			
150	SDCARD_DET_N	1.8V	GPIO_98	B-PD	√
151	SDC2_DAT3	1.8/2.95V		B	
152	SDC2_DAT2	1.8/2.95 V		B	
153	SDC2_DAT1	1.8/2.95 V		B	
154	SDC2_DAT0	1.8/2.95 V		B	
155	SDC2_CMD	1.8/2.95 V		B	
156	SDC2_CLK	1.8/2.95 V		DO	
157	GND				
158	PM_GPIO_01	1.8V	PM6125_GPIO_01	DI	
159	ADC2	0~ 1.875V	PM6125_GPIO_02		
160	GND				
161	NC				
162	GND				
163	NC				
164	GND				
165	NC				
166	GND				
167	GPIO_6_TP_I2C_SDA	1.8V	GPIO_6	B-PD	
168	GND				
169	PM_GPIO_09	1.8V	PM6125_GPIO_09	B-PD	
170	GND				
171	GND				
172	VREG_L20A_UIM2	1.8/2.95 V			
173	GND				

174	UIM2_DATA	1.8/2.95 V	GPIO_72	B-PD	
175	GND				
176	UIM2_CLK	1.8/2.95 V	GPIO_73	B-PD	
177	GND				
178	UIM2_RESET	1.8/2.95 V	GPIO_74	B-PD	
179	GND				
180	UIM2_DETECT	1.8V	GPIO_75	B-PD	√
181	GND				
182	GPIO_24_UART_TX	1.8V	GPIO_24	B-PD	
183	GPIO_25_UART_RX	1.8V	GPIO_25	B-PD	√
184	GND				
185	GNSS_LNA_CTRL	1.8V		B-PD	
186	GPIO_83	1.8V	GPIO_83	B-PD	√
187	GPIO_100	1.8V	GPIO_100	B-PD	√
188	GPIO_89	1.8V	GPIO_89	B-PD	√
189	GND				
190	USB_CC2				
191	USB_CC1				
192	GND				
193	USB0_SS_RX0_P				
194	USB0_SS_RX0_M				
195	GND				
196	USB0_SS_TX0_P				
197	USB0_SS_TX0_M				
198	GND				
199	GND				
200	USB_IN_MID				
201	GND				
202	AUDIO_AUX_P				
203	AUDIO_AUX_M				
204	GND				
205	UIM1_DETECT	1.8V	GPIO_79	B-PD	√
206	GND				
207	UIM1_RESET	1.8 /2.95 V	GPIO_78	B-PD	
208	UIM1_CLK	1.8 /2.95 V	GPIO_77	B-PD	
209	GND				
210	UIM1_DATA	1.8 /2.95 V	GPIO_76	B-PD	
211	VREG_L19A_UIM1	1.8 /2.95 V			

212	GND				
213	GND				
214	GND				
215	GND				
216	GND				
217	GND				
218	GND				
219	GND				
220	GND				
221	GND				
222	GND				
223	GND				
224	GND				
225	GND				
226	GND				
227	GND				
228	GND				
229	GND				
230	GND				
231	GND				
232	GND				
233	NC				
234	GND				
235	MIC_BIAS3	1.6~2.85V			
236	MIC3_N				
237	GND				
238	MIPI_CS11_CLK_P				
239	MIPI_CS11_CLK_N				
240	MIPI_CS11_LANE1_P				
241	MIPI_CS11_LANE1_N				
242	MIPI_CS11_LANE0_P				
243	MIPI_CS11_LANE0_N				
244	MIPI_CS11_LANE2_P				
245	MIPI_CS11_LANE2_N				
246	MIPI_CS11_LANE3_P				
247	MIPI_CS11_LANE3_N				
248	GND				
249	LCD_VSN	-6.0~-4.0V			
250	LCD_VSP	4.0~6.0V			
251	APPS_I2C_SDA	1.8V	GPIO_4	B-PD	√
252	APPS_I2C_SCL	1.8V	GPIO_5	B-PD	

253	GRFC_8	1.8V	GPIO_58	B-PD	
254	PMI_GPIO_01	1.8V	PMI632_GPIO_01	B-PD	
255	GND				
256	CAM_MCLK2	1.8V	GPIO_36	B-PD	√
257	GND				
258	CAM_MCLK3	1.8V	GPIO_44	B-PD	√
259	GND				
260	CAM2_RST_N	1.8V	GPIO_42	B-PD	√
261	GPIO_123	1.8V	GPIO_123	B-PD	√
262	GPIO_21	1.8V	GPIO_21	B-PD	√
263	PMI_GPIO_03_SKIN_T HERM		PMI632_GPIO_03		
264	PMI_GPIO_05		PMI632_GPIO_05		
265	RFFE3_DATA	1.8V	GPIO_64	B-PD	
266	RFFE3_CLK	1.8V	GPIO_65	B-PD	
267	CPU_USB_PHY_PS	1.8V	GPIO_102	B-PD	√
268	GRFC_9	1.8V	GPIO_59	B-PD	√
269	GPIO_124	1.8V	GPIO_124	B-PD	
270	TP_B				
271	GPIO_45	1.8V	GPIO_45	B-PD	√
272	GND				
273	GND				
274	GND				
275	ACCL_GYRO_DRDY_I NT	1.8V	GPIO_80	B-PD	√
276	GND				
277	MIPI_CSI2_LANE3_N				
278	MIPI_CSI2_LANE3_P				
279	MIPI_CSI2_LANE2_N				
280	MIPI_CSI2_LANE2_P				
281	GND				
282	USB_PHY_PS	1.8V			
283	NC	1.8V			
284	GPIO_92	1.8V	GPIO_92	B-PD	√
285	VPH_PWR	0-4.75V			
286	VPH_PWR	0-4.75V			
287	VPH_PWR	0-4.75V			
288	USB_VBUS_IN	5V~9V			
289	USB_VBUS_IN	5V~9V			
290	GND				

291	PMI_GPIO_06	1.8V	PMI632_GPIO_06	B-PD	
292	PMI_GPIO_02	1.8V	PMI632_GPIO_02	B-PD	
293	GPIO_130	1.8V	GPIO_130	B-PD	√
294	GPIO_86	1.8V	GPIO_86	B-PD	√
295	RED_LED				
296	GREEN_LED				
297	BLUE_LED				
298	GND				
299	GND				
300	NC				
301	RESERVED				
302	MIC4_N				
303	MIC4_P				
304	TP_A				
305	FLASH_LED1				
306	FLASH_LED2				
307	NC				
308	GND				
309	DMIC1_CLK	1.8V	GPIO_125	B	
310	DMIC1_DATA	1.8V	GPIO_126	DI	√
311	DMIC2_CLK	1.8V	GPIO_127	B	
312	DMIC2_DATA	1.8V	GPIO_128	DI	√
313	GND				
314	GPIO_131_CAM_AVDD 1_2_2P85_EN	1.8V	GPIO_131	B-PD	√
315	CAM3_RST_N	1.8V	GPIO_41	B-PD	
316	GRFC_4				
317	GPIO_118	1.8V	GPIO_118	B-PD	√
318	GPIO_93	1.8V	GPIO_93	B-PD	√
319	GND				
320	USB0_DP_AUX_M				
321	USB0_DP_AUX_P				
322	GND				
323	USB0_SS_RX1_M				
324	USB0_SS_RX1_P				
325	USB0_SS_TX1_P				
326	USB0_SS_TX1_M				
327	GND				
328	PM_GPIO_04		PM6125_GPIO_04	B-PD	

329	RESERVED				
330	CBL_PWR_N				
331	VREG_L14A_1P8	1.8V			
332	BATT_ID				
333	BATT_THERM				
334	NC				
335	GND				
336	GND				
337	VIB_DRV_P				
338	GND				
339	VBATT_SNS_P				
340	VBATT_SNS_M				
341	GND				
342	RESERVED				
343	RESERVED				
344	GND				
345	VREG_L15A_3P128				
346	NC				
347	GND				
348	GND				

NOTE

In the column of the QCM6125 PIN, all the GPIO_XX are configurable GPIOs except the UIM Cards signals. But pulling up the following GPIOs would affect the module's boot-up. These GPIOs are including GPIO_32, GPIO_56, GPIO_86, GPIO_87, GPIO_99, GPIO_100, GPIO_101, and GPIO_118.

Table 5: Pin Description

PIN Name	PIN Num	I/O	Description	Note
Power Supply				
VREG_L21A_2P704	5, 6	PO	Power Supply of the TP AVDD and the LCD AVDD 2.8V	External Power Supply, Highly recommend a capacitor of 2.2-4.7uF parallel connection, suspend if no connection.
VREG_L9A_1P8	10, 12	PO	Mainly for external GPIO pull up and the 1.8V power level conversion, the TP_IOVDD 1.8V,	External Power Supply, Highly recommend a capacitor of 2.2-4.7uF

			etc.	parallel connection, suspend if no connection.
VREG_L14A_1P8	331	PO	Mainly for the Audio Codec Power Supply	External Power Supply, Highly recommend a capacitor of 2.2-4.7uF parallel connection, suspend if no connection.
VRTC	79	PI/PO	3V Secondary Power Supply Input and Charging Output	Suspend if no connection.
VBAT	83 84 85	PI/PO	Primary Power Supply, Single Lithium Battery Input	Maximum Current 3A, Highly recommend increasing the power of the diode to prevent the surge and the static electricity
VPH_PWR	285 286 287	PO	Power Output, provide by battery or charging	Maximum Current 2A, External circuit needs this Pin for precision electric quantity detection

Ground

GND	1,3,15,18,27,29,32,40,42,48,50,59,61,70,81,82,86,88,96,103,114,123,134,145,148,157,160,162,164,166,168,170,171,173,175,177,179,181,184,189,192,195,198,199,201,204,206,209,212,213,214,215,216,217,218,219,220,221,222,223,224,225,226,227,228,229,230,231,232,234,237,248,255,257,259,272,273,274,276,281,290,298,299,308,313,319,322,327,335,336,338,341,344,347,348			
-----	--	--	--	--

Micro-USB/Type-C/DP Interface

USB_VBUS_IN	87 288 289	PI/P O	VBUS Power Input, USB1 OTG Mode 5V Power Output	Highly recommend increasing the power of the diode to prevent the surge and the static electricity
USB_DP	146	AI/A O	USB_HS Differential Signal	Require 90+-10% impedance control
USB_DM	147	AI/A O		
USB_CC2	190	AI/A O	USB Type-C Connector Direction Detection Pin2	
USB_CC1	191	AI/A O	USB Type-C Connector Direction Detection Pin1, OTG Mode ID Pin	
USB0_SS_RX0_P	193	AI	USB Super-Speed Receiver P, or DP_LANE3_P for DP	

USB0_SS_RX0_M	194	AI	USB Super-Speed Receiver M, or DP_LANE3_M for DP
USB0_SS_TX0_P	196	AO	USB Super-Speed Transmitter P, or DP_LANE2_P for DP
USB0_SS_TX0_M	197	AO	USB Super-Speed Transmitter M, or DP_LANE2_M for DP
USB0_SS_RX1_M	323	AI	USB Super-Speed Receiver M, or DP_LANE0_M for DP
USB0_SS_RX1_P	324	AI	USB Super-Speed Receiver P, or DP_LANE0_P for DP
USB0_SS_TX1_P	325	AO	USB Super-Speed Transmitter P, or DP_LANE1_P for DP
USB0_SS_TX1_M	326	AO	USB Super-Speed Transmitter M, or DP_LANE1_M for DP
USB0_DP_AUX_M	320	AI/A O	Auxiliary Channel Differential Signal for DP LCD M
USB0_DP_AUX_P	321	AI/A O	Auxiliary Channel Differential Signal for DP LCD P
VREG_L15A_3P128	345	PO	DP Switch VDD Power Supply
CPU_USB_PHY_PS	267	DI	Connect to Ground for Micro-USB, Connect to Pin 282 for Type-C
USB_PHY_PS	282	DO	Connect to Pin 267 for Type-C

UIM Card Interface

VREG_L20A_UIM 2	172	PO	LDO L20A Output for SIM Card2 Power Supply, 1.8V/2.95V Dual Voltage	Highly recommend an external capacitor of 220nF parallel connection
UIM2_DATA	174	DI/DO	SIM Card2 Data Signal	Do not use these signals as configurable GPIO
UIM2_CLK	176	DO	SIM Card2 Clock Signal	
UIM2_RESET	178	DO	SIM Card2 Reset Signal	
UIM2_DETCET	180	DI	SIM Card2 insert detecting signal, Active Low when inserting the SIM Card	1.8V Voltage Range, SIM Card detect pin is low active by default, Highly recommend connecting to the ground if the SIM Card does not support the hot-join detect.
UIM1_DETCET	205	DI	SIM Card1 insert detecting signal, Active Low when inserting the SIM Card	1.8V Voltage Range, SIM Card detect pin is low active by default, Highly recommend connecting to the ground if the SIM Card does not support the hot-join detect.

UIM1_RESET	207	DO	SIM Card1 Reset Signal	Do not use these signals as configurable GPIO
UIM1_CLK	208	DO	SIM Card1 Clock Signal	
UIM1_DATA	210	DI/DO	SIM Card1 Data Signal	
VREG_L19A_UIM1	211	PO	LDO L19A Output for SIM Card1 Power Supply, 1.8V/2.95V Dual Voltage	Highly recommend an external capacitor of 220nF parallel connection

SDIO/SD Card Interface

VREG_L5A_SDC2	80	PO	LDO L5A Power Output, 1.8V/2.95V	Only for pulling up the SD Card Data Signal
VREG_L22A_2P96	149	PO	LDO L5B Power Output for SD VDD, Typical Voltage 2.95V, Maximum Output Current 800mA	Routing lines in PCB requires an 800mA standard if supporting the SD3.0, Highly recommend an external capacitor of 2.2uF parallel connection
SDCARD_DET_N	150	DI	SD Card insert detecting signal, Active Low when inserting the SD Card	1.8V Voltage Range, Highly recommend an external pull up resistor, suspend if no connection.
SDC2_DATA3	151	DI/DO	SDIO Data3	The SDIO signal line needs to go through the impedance lines with the value at 50 ohm \pm 10%.
SDC2_DATA2	152	DI/DO	SDIO Data2	
SDC2_DATA1	153	DI/DO	SDIO Data1	
SDC2_DATA0	154	DI/DO	SDIO Data0	
SDC2_CMD	155	DI/DO	SDIO Command	
SDC2_CLK	156	DO	SDIO Clock	

Touching Screen Interface

TP_I2C_SDA	167	DI/DO	TP I2C Data Signal	Highly recommend an external 2.2KR resistor pulling up to the VREG_L9A_1P8.
TP_I2C_SCL	117	DO	TP I2C Clock Signal	
TP_INT_N	119	DI	TP Interruption Signal	Highly recommend an external 10KR resistor pulling up to the VREG_L9A_1P8.
TP_RST_N	118	DO	TP Reset Signal	With Boot function, avoid an external pull up.

Displaying Screen Interface

MIPI_DSI0_CLK_P	135	AO	LCD0 MIPI Signals	Require the value at 85 Ω \pm 15% for the differential impedance on the MIPI signal routings.
MIPI_DSI0_CLK_N	136	AO		
MIPI_DSI0_LANE0_P	137	AI/AO		
MIPI_DSI0_LANE0_N	138	AI/AO		
MIPI_DSI0_LANE1_P	139	AI/AO		

MIPI_DSI0_LANE1_N	140	AI/AO		
MIPI_DSI0_LANE2_P	141	AI/AO		
MIPI_DSI0_LANE2_N	142	AI/AO		
MIPI_DSI0_LANE3_P	143	AI/AO		
MIPI_DSI0_LANE3_N	144	AI/AO		
MIPI_DSI1_CLK_P	124	AO		
MIPI_DSI1_CLK_N	125	AO	LCD1 MIPI Signals	Require the value at 85 Ω ±15% for the differential impedance on the MIPI signal routings.
LCD0_RST_N	121	DO	LCD0 Reset Signal	
GPIO_89	188	DO	LCD0 TE Signal	
GPIO_83	186	DI	LCD0 ID PIN	
LCD_VSN	249	PO	Integrated LCM Bias Voltage -5.4V	Voltage Range: -6V ~ -4V Typ. : -5.4V
LCD_VSP	250	PO	Integrated LCM Bias Voltage +5.5V	Voltage Range :4V ~ 6V Typ. : +5.5V
PWM1	33	DO	Output PWM1 Control for Backlight	

Camera Interface

MIPI_CSI0_LANE3_N	104	AI/AO	MIPI CSI0 Data3 Negative	Default Rear Camera, Require the value at 85 Ω ±15% for the differential impedance on the High-Speed MIPI signal routings.
MIPI_CSI0_LANE3_P	105	AI/AO	MIPI CSI0 Data3 Positive	
MIPI_CSI0_LANE2_N	106	AI/AO	MIPI CSI0 Data2 Negative	
MIPI_CSI0_LANE2_P	107	AI/AO	MIPI CSI0 Data2 Positive	
MIPI_CSI0_LANE1_N	108	AI/AO	MIPI CSI0 Data1 Negative	
MIPI_CSI0_LANE1_P	109	AI/AO	MIPI CSI0 Data1 Positive	
MIPI_CSI0_LANE0_N	110	AI/AO	MIPI CSI0 Data0 Negative	
MIPI_CSI0_LANE0_P	111	AI/AO	MIPI CSI0 Data0 Positive	
MIPI_CSI0_CLK_N	112	AI	MIPI CSI0 Clock Negative	
MIPI_CSI0_CLK_P	113	AI	MIPI CSI0 Clock Positive	
MIPI_CSI2_LANE3_N	277	AI/AO	MIPI CSI2 Data3 Negative	Default Front Camera, Require the value at 85 Ω ±15% for the differential impedance on the High-Speed MIPI signal routings.
MIPI_CSI2_LANE3_P	278	AI/AO	MIPI CSI2 Data3 Positive	
MIPI_CSI2_LANE2_N	279	AI/AO	MIPI CSI2 Data2 Negative	
MIPI_CSI2_LANE2_P	280	AI/AO	MIPI CSI2 Data2 Positive	
MIPI_CSI2_LANE1_N	97	AI/AO	MIPI CSI2 Data1 Negative	
MIPI_CSI2_LANE1_P	98	AI/AO	MIPI CSI2 Data1 Positive	
MIPI_CSI2_LANE0_N	99	AI/AO	MIPI CSI2 Data0 Negative	Divide into two cameras with a 2-Lane and an 1-Lane.
MIPI_CSI2_LANE0_P	100	AI/AO	MIPI CSI2 Data0 Positive	
MIPI_CSI2_CLK_N	101	AI	MIPI CSI2 Clock Negative	
MIPI_CSI2_CLK_P	102	AI	MIPI CSI2 Clock Positive	
MIPI_CSI1_LANE3_N	247	AI/AO	MIPI CSI1 Data3 Negative	

MIPI_CSI1_LANE3_P	246	AI/AO	MIPI CSI1 Data3 Positive	Default 2 nd Rear Camera, Require the value at 85 Ω ±15% for the differential impedance on the High-Speed MIPI signal routings.
MIPI_CSI1_LANE2_N	245	AI/AO	MIPI CSI1 Data2 Negative	
MIPI_CSI1_LANE2_P	244	AI/AO	MIPI CSI1 Data2 Positive	
MIPI_CSI1_LANE1_N	241	AI/AO	MIPI CSI1 Data1 Negative	
MIPI_CSI1_LANE1_P	240	AI/AO	MIPI CSI1 Data1 Positive	
MIPI_CSI1_LANE0_N	243	AI/AO	MIPI CSI1 Data0 Negative	
MIPI_CSI1_LANE0_P	242	AI/AO	MIPI CSI1 Data0 Positive	
MIPI_CSI1_CLK_N	239	AI	MIPI CSI1 Clock Negative	
MIPI_CSI1_CLK_P	238	AI	MIPI CSI1 Clock Positive	
CAM1_PWD_N	90	DO	Camera1 Power Down Signal	Default 2 nd Rear Camera Power Down Signal
CAM1_RST_N	91	DO	Camera1 Reset Signal	Default 2 nd Rear Camera Reset Signal
CAM0_RST_N	92	DO	Camera0 Reset Signal	Default Primary Rear Camera Reset Signal
CAM0_PWD_N	93	DO	Camera0 Power Down Signal	Default Primary Rear Camera Power Down Signal
CAM2_RST_N	260	DO	Camera2 Reset Signal	Default Primary Front Camera Reset Signal
CAM3_RST_N	315	DO	Camera3 Reset Signal, Camera AVDD LDO Enable Pin	Default 2 nd Front Camera Reset Signal
CAM_I2C0_SDA	94	DI/DO	Camera I2C0 Data	I2C0 applies for Primary Rear Camera, I2C1 applies for Front Camera or 2 nd Rear Camera, Notice that distinguish I2C register address when applying for multiple cameras. Highly recommend an external 2.2KR resistor pulling up to the VREG_L12A_1P8.
CAM_I2C0_SCL	95	DO	Camera I2C0 Clock	
CAM_I2C1_SDA	54	DI/DO	Camera I2C1 Data	
CAM_I2C1_SCL	55	DO	Camera I2C1 Clock	
CAM_MCLK0	116	DO	Camera0 Primary Clock	Default Primary Rear Camera Clock Signal
CAM_MCLK1	115	DO	Camera1 Primary Clock	Default 2 nd Rear Camera Clock Signal
CAM_MCLK2	256	DO	Camera2 Primary Clock	Default Primary Front Camera Clock Signal
CAM_MCLK3	258	DO	Camera3 Primary Clock, Camera DVDD LDO Enable Pin	Default 2 nd Front Camera Clock Signal

GPIO_21	262	DO	Camera DVDD LDO Enable Pin	
GPIO_45	271	DO	Camera AFVDD LDO Enable Pin	
GPIO_131_CAM_AVD D1_2_2P85_EN	314	DO	Camera AVDD LDO Enable Pin	
VPH_OUT	4	PO	Camera AVDD/AFVDD LDO Power Supply, Highly recommend an external capacitor of 2.2-4.7nF parallel connection.	Voltage Range: 3.0 ~ 4.4V
VREG_S6A_1P352	8	PO	Camera DVDD(1.1V/1.2V) LDO Power Supply, Highly recommend an external capacitor of 2.2-4.7nF parallel connection.	Typical value: 1.352V
VREG_L12A_1P8	11	PO	Camera IOVDD(1.8V) Power Supply, Highly recommend an external capacitor of 2.2-4.7nF parallel connection.	Typical value: 1.8V

Key Interface

KEY_VOL_UP_N	44	DI	Volume Up Key	Avoid an external pull up, suspend if no connection.
KEY_VOL_DOWN_N	43	DI	Volume Down Key	Suspend if no connection.
KPD_PWR_N	14	DI	Power Key	

Sensor Interface

SENSOR_I2C_SCL	38	DO	Sensor I2C Clock Signal	Highly recommend an external 2.2KR resistor pulling up to the VREG_L9A_1P8
SENSOR_I2C_SDA	39	DI/DO	Sensor I2C Data Signal	
GPIO_94	53	DI	Hal Sensor Interruption Pin	
GPIO_82	58	DO	Magnetic Sensor Interruption Pin	
ACCEL_INT	56	DI	Accelerate Sensor Interruption Pin	
ALSP_INT	57	DI	Light Sensor Interruption Pin	
ACCL_GYRO_DRDY_I NT	275	DI	Gyroscope Sensor Interruption Pin	
SNSR_I3C_SDA	72	DI/DO	Sensor I3C Clock Signal	Highly recommend an external 2.2KR resistor pulling up to the VREG_L9A_1P8
SNSR_I3C_SCL	73	DO	Sensor I3C Data Signal	

Audio Interface

SPKR_OUT_P	16	AO	Speaker	Lineout	Differential Pair Routing, Stereo
------------	----	----	---------	---------	-----------------------------------

			Positive		ground plane
SPKR_OUT_N	17	AO	Speaker Negative	Lineout	
EAR_P	19	AO	Headphone Positive	Output	Differential Pair Routing, Stereo ground plane
EAR_N	20	AO	Headphone Negative	Output	
HPH_L	21	AO	Headphone Left-Channel		Isolate the Left- and the Right-Channel by the Main HPH_REF Ground, Stereo ground plane
HPH_REF	22	AI	Headphone Reference Ground	Main	
HPH_R	23	AO	Headphone Right-Channel		
HS_DET	24	AI	Headphone Detect	Push-in	
MIC2_P	28	AI	Headphone Microphone Positive	Input	Pseudo Differential Pair Routing, Stereo ground plane
MIC1_N	30	AI	Primary Input Negative	Microphone	Differential Pair Routing, Stereo ground plane
MIC1_P	31	AI	Primary Input Positive	Microphone	
MIC3_P	9	AI	Denoise Input Positive	Microphone	Differential Pair Routing, Stereo ground plane
MIC3_N	236	AI	Denoise Input Negative	Microphone	
MIC_BIAS1	7	PO	Microphone Voltage	Bias	Apply Bias Voltage for Digital Microphone and Silicon Microphone, Suspend on Electret Microphone
MIC_BIAS3	235	PO	Headphone Microphone Voltage	Bias	Headphone Bias Voltage
DMIC1_CLK	309	DO	Digital Clock Signal	Microphone	
DMIC1_DATA	310	DI	Digital Data Signal	Microphone	
DMIC2_CLK	311	DO	Digital Clock Signal	Microphone	
DMIC2_DATA	312	DI	Digital Data Signal	Microphone	
AUDIO_AUX_P	202	AO	Audio Lineout Positive		
AUDIO_AUX_M	203	AO	Audio Lineout Negative		

Radio Frequency Antenna Interface

ANT_TRX	60	AI/AO	2G/3G/4G	Main	Antenna	SIM8970x: ANT_TRX
---------	----	-------	----------	------	---------	-------------------

			Interface	SIM8070: NC
ANT_DRX	41	AI	4G DRX Antenna Interface	SIM8970x: ANT_DRX SIM8070: NC
ANT_GNSS	49	AI	GNSS Antenna Interface	SIM8970x: ANT_GNSS SIM8070: NC
ANT_WIFI/BT	2	AI/AO	WIFI/BT Antenna Interface	
UART Interface				
DEBUG_UART_RX	36	DI	Debug UART Data Receiver	Mainly for the module's Debugging
DEBUG_UART_TX	37	DO	Debug UART Data Transmitter	
ADC Interface				
ADC1	34	AI	ADC Detection 1	Input Voltage Range: 0 ~ 1.875V
ADC2	159	AI	ADC Detection 2	Input Voltage Range: 0 ~ 1.875V
MOTOR Interface				
VIB_DRV_P	337	AO	Motor Drive Positive	Available for Linear Motor
Flash LED Interface				
FLASH_LED1	305	AO	Flash LED1 Channel	Maximum Current 1.5A
FLASH_LED2	306	AO	Flash LED2 Channel	Maximum Current 1.5A
LED Interface				
RED_LED	295	AO	Red Indicator	PWM1 Lighting Adjustment each Channel
GREEN_LED	296	AO	Green Indicator	
BLUE_LED	297	AO	Blue Indicator	Maximum Current 12mA each Channel
Forced Download Interface				
FORCED_USB_BOOT	13	DI	USB Forced Boot Signal, Forced connect to the VREG_L9A_1P8 Pin when booting up the device	Avoid an external pull up, Reserved Testing Points
GPIO				
GPIO_0	51	DI/DO	GPIO_0	
GPIO_1	52	DI/DO	GPIO_1	
GPIO_2	26	DI/DO	GPIO_2	
GPIO_3	25	DI/DO	GPIO_3	
GPIO_31	45	DI/DO	GPIO_31	
GPIO_30	46	DI/DO	GPIO_30	
GPIO_32	47	DI/DO	GPIO_32	Avoid an external pull up due to the BOOT function
GPIO_113	62	DI/DO	GPIO_113	PRI_MI2S_SCK
GPIO_114	63	DI/DO	GPIO_114	PRI_MI2S_WS
GPIO_115	64	DI/DO	GPIO_115	PRI_MI2S_DATA0
GPIO_116	65	DI/DO	GPIO_116	PRI_MI2S_DATA1
GPIO_95	66	DI/DO	GPIO_95	

GPIO_26	67	DI/DO	GPIO_26	
GPIO_27	68	DI/DO	GPIO_27	
GPIO_8	69	DI/DO	GPIO_8	
GPIO_9	71	DI/DO	GPIO_9	
GPIO_85	74	DI/DO	GPIO_85	
GPIO_84	75	DI/DO	GPIO_84	
GPIO_43	76	DI/DO	GPIO_43	
GPIO_15	77	DI/DO	GPIO_15	
GPIO_14	78	DI/DO	GPIO_14	
GPIO_33	89	DI/DO	GPIO_33	
GPIO_101	120	DI/DO	GPIO_101	Avoid an external pull up due to the BOOT function
GPIO_49	122	DI/DO	GPIO_49	
GPIO_24	182	DI/DO	GPIO_24	UART_TX
GPIO_25	183	DI/DO	GPIO_25	UART_RX
GPIO_100	187	DI/DO	GPIO_100	Avoid an external pull up due to the BOOT function
APPS_I2C_SDA	251	DI/DO	GPIO_4	APPS_I2C_SDA
APPS_I2C_SCL	252	DI/DO	GPIO_5	APPS_I2C_SCL
GRFC_8	253	DI/DO	GPIO_58	Default Antenna Tuner
GPIO_123	261	DI/DO	GPIO_123	
RFFE3_DATA	265	DI/DO	GPIO_64	Default Antenna Tuner, Avoid an external pull up due to the BOOT function
RFFE3_CLK	266	DI/DO	GPIO_65	Default Antenna Tuner
GRFC_9	268	DI/DO	GPIO_59	Default Antenna Tuner
GPIO_124	269	DI/DO	GPIO_124	
GPIO_92	284	DI/DO	GPIO_92	
GPIO_130	293	DI/DO	GPIO_130	
GPIO_86	294	DI/DO	GPIO_86	Avoid an external pull up due to the BOOT function
GRFC_4	316	DI/DO	GPIO_56	Default Antenna Tuner, Avoid an external pull up due to the BOOT function
GPIO_118	317	DI/DO	GPIO_118	Avoid an external pull up due to the BOOT function
GPIO_93	318	DI/DO	GPIO_93	
PM_GPIO_01	158	DI/DO	PM_GPIO_01	PM6125 GPIO_01
PM_GPIO_09	169	DI/DO	PM_GPIO_09	PM6125 GPIO_09
PM_GPIO_04	328	DI/DO	PM_GPIO_04	PM6125 GPIO_04, Avoid an external pull up due to the BOOT function
PMI_GPIO_01	254	DI/DO	PMI_GPIO_01	PMI632 GPIO_01

PMI_GPIO_03	263	AI	PMI_GPIO_03	SKIN_THERM Detection ADC Input, Highly recommend an external 47KR resistor pulling down to the ground when no connection.
PMI_GPIO_05	264	DI/DO	PMI_GPIO_05	PMI632 GPIO_05
PMI_GPIO_06	291	DI/DO	PMI_GPIO_06	PMI632 GPIO_06
PMI_GPIO_02	292	DI/DO	PMI_GPIO_02	PMI632 GPIO_02

Other Interface

CBL_PWR_N	330	DO	Pull down for power on	
GNSS_LNA_CTRL	185	DO	Internal GNSS LNA Control Signal Output	Suspend if no connection.
TP_B	270	-	Testing Pin, Connect to TP_A on the module for security design	Suspend if no connection.
TP_A	304	-	Testing Pin, Connect to TP_B on the module for security design	Suspend if no connection.
BATT_ID	332	AI	Battery ID Pin, Highly recommend an external 100KR resistor connecting to the ground.	Avoid suspend, An external 100KR resistor pulling down to the ground if no connection.
BATT_THERM	333	AI	Battery Thermal Detect Pin, Highly recommend an external 47KR NTC resistor connecting to the ground.	Avoid suspend, An external 47KR resistor pulling down to the ground if no connection.
VBATT_SNS_P	339	AI	Battery Voltage Detection Positive, Connect to the battery Positive Pin.	Avoid suspend
VBATT_SNS_M	340	AI	Battery Voltage Detection Negative, Connect to the battery Negative Pin.	Avoid suspend

NC Pins (NC)

NC	126-133,161,163,165,233,283,300,307,334,346	Suspend if no connection.
----	---	---------------------------

Reserved Pins

RESERVED	35,200,301,302,303,329,342,343	Suspend if no connection.
----------	--------------------------------	---------------------------

NOTE

- 1、 Highly recommend all the GND pins are connecting to the ground.
- 2、 Highly recommend all the RESERVED and the unused pins disconnected.
- 3、 Note that, for SIM8070, pin ANT_TRX, pin ANT_DRX, and pin ANT_GNSS should be disconnected.

3 Interface Applications

3.1 Power Supply

The VBAT Input power range of the SIM8970 module is 3.4V to 4.4V, and the typical voltage is 3.9V. The instantaneous peak current of the SIM8970 module could reach 3A. So, to enable the module is running smoothly, the power supply should be able to provide the peak current up to 3A. If the power supply is designed improperly, there would be a large voltage drop on the VBAT. The shutdown voltage of the SIM8970 module is 3.2V. If the voltage drop on the VBAT is lower than 3.2V, the module would power off.

3.1.1 Pin Overview

SIM8970x series module supports a single lithium battery power supply (4.2V or 4.35V battery cell). It also supports the other types of batteries. But the maximum voltage could not exceed the maximum allowance voltage of the module. Otherwise, the module would be burned. In terms of the non-battery power supply applications, the module would power by an LDO when the DC input is up to 5V. The reference design is showing in Figure 3.

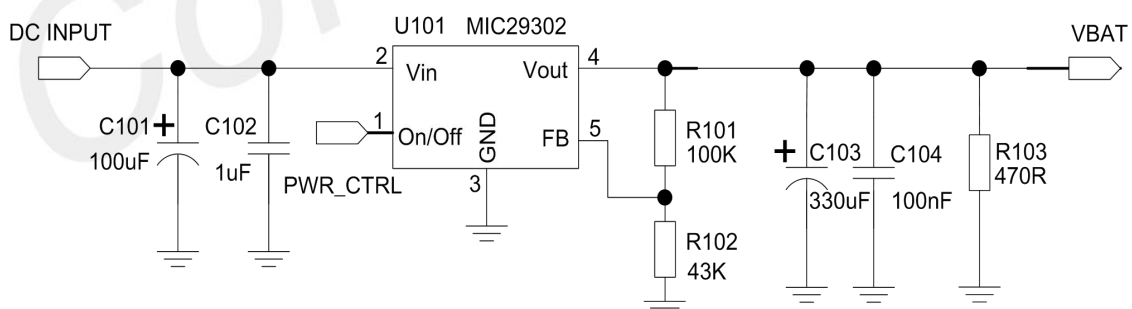

Figure 3: LDO Power Supply Reference Design

NOTE

Since the current consumption of the module is very small when powering off or sleeping. Highly recommend adding R103 as the minimum load to ensure the MIC29302 is working smoothly with the light load. Please refer to the MIC29302's specification for detailed information.

Highly recommend selecting a relative high efficiency switching power supply for hardware design when the difference between the input (DC Input) and the output (VBAT) is too large. The reference design is showing in Figure 4.

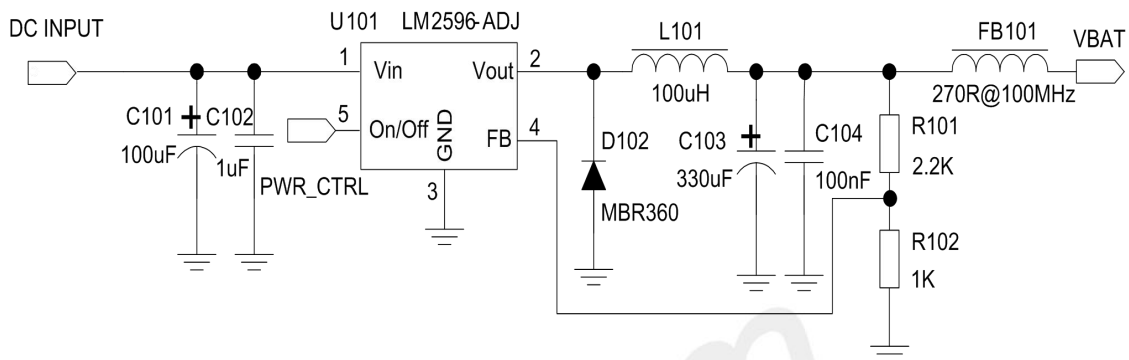

Figure 4: DC-DC Power Supply Reference Design

NOTE

1. Highly recommend disconnect the VBAT power supply to power off the module when the module is running abnormally. After that, restart the module by powering.
2. The module supports the charging function. There is a need to turn off the charging function in the software patch when the customers are using the power supply without the charging function. Or connect Schottky diodes in series on the VBAT channel to prevent the current anti-flowing into the chip.

3.1.2 Power Supply Stability Design

Highly recommend place bypass capacitors and voltage stabilizing components near the VBAT Pin to enhance the stability of the power supply. The reference design is showing in the Figure 5.

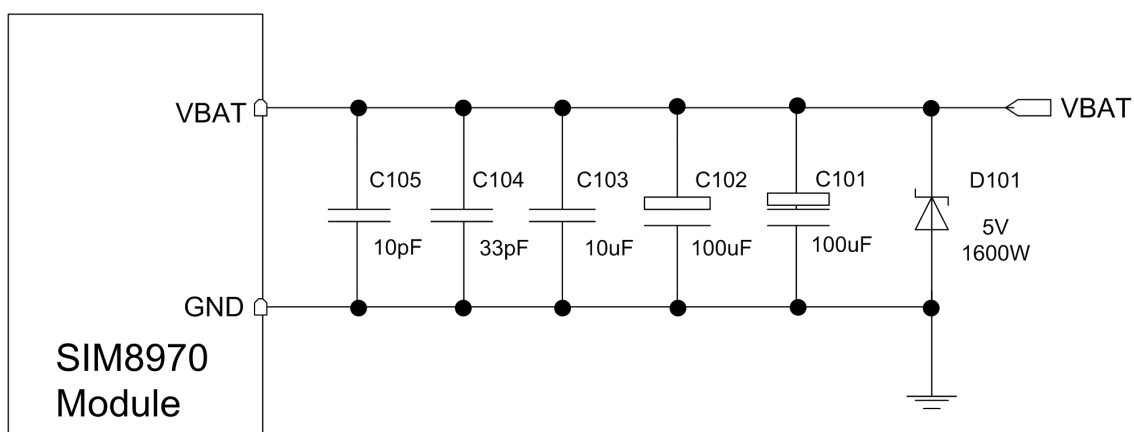

Figure 5: VBAT Input Reference Design

In Figure 5, C101 and C102 are two Low-ESR 100uF tantalum capacitors. C103 is a 1uF to 10uF ceramic capacitor. The function of C104 and C105 is to decrease the high frequency interference. D101 is a 5V/1600W transient voltage suppression diode, preventing the chip from being damaged by surge. For PCB wiring, the capacitors and the diodes should be close to the VBAT Pin as far as possible, and the VBAT wiring should be as short as possible with the width at least 3mm.

Table 6: Recommended TVS Diode

	Vendor	Manufacture Number	Power(Watts)	Package
1	Prisemi	PTVSHC3N4V8U	3200W	DFN2×2-3L
2	Prisemi	PTVSHC2EN5VU	1600W	DFN1610-2L

3.2 Power On & Power Off

The on-off of the SIM8970x series module has two status, including the normal on-off and the abnormal on-off. In terms of the high- and low-pressure, and the high- and low-temperature, it should be working within the maximum voltage range when running the module. Otherwise, exceeding the absolute maximum voltage range would cause permanent damage to the module.

3.2.1 Power On

KPD_PWR_N Pin defines as the boot-up key when the VBAT is powering on, and triggering KPD_PWR_N with at least 2s low-level pulse starts the module. KPD_PWR_N Pin has internal pull-up, and the typical high-level voltage is 1.8V. The reference design is showing as below.

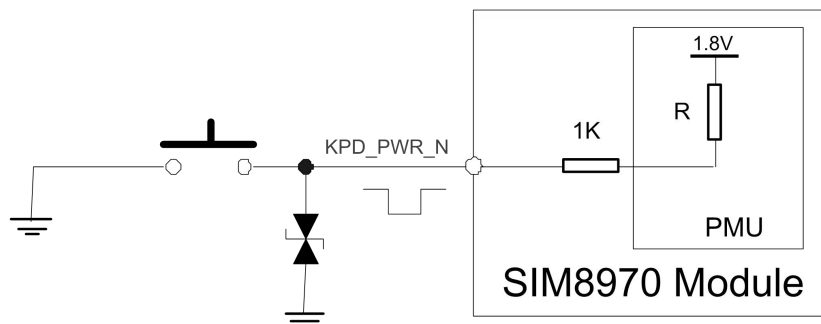

Figure 6: Power On/Off Design with a Key

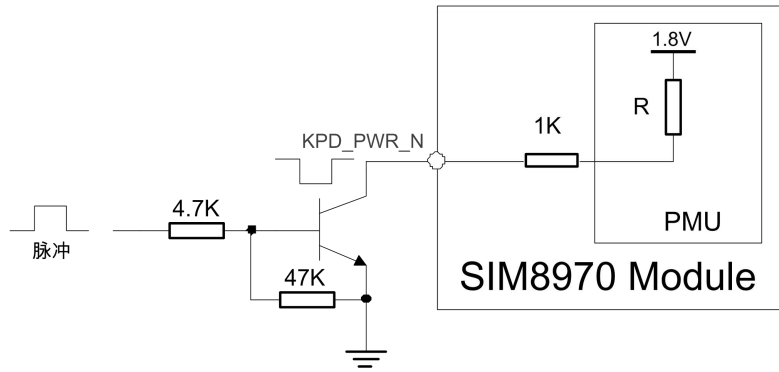

Figure 7: Power On/Off Design with an OC Gate

Highly recommend the customers consider the KPD_PWR_N Pin's electrical characteristics when designing. The electrical characteristics are showing in Table 7.

Table 7: KPD_PWR_N Features

Parameters	Description	Minimum	Typical	Maximum	Unit
V _{IH}	High-Level Input Voltage	1.4	-	-	V
V _{IL}	Low-Level Input Voltage	-	-	0.6	V

3.2.2 Power On Sequence

Figure 8 shows the power on sequence of the module.

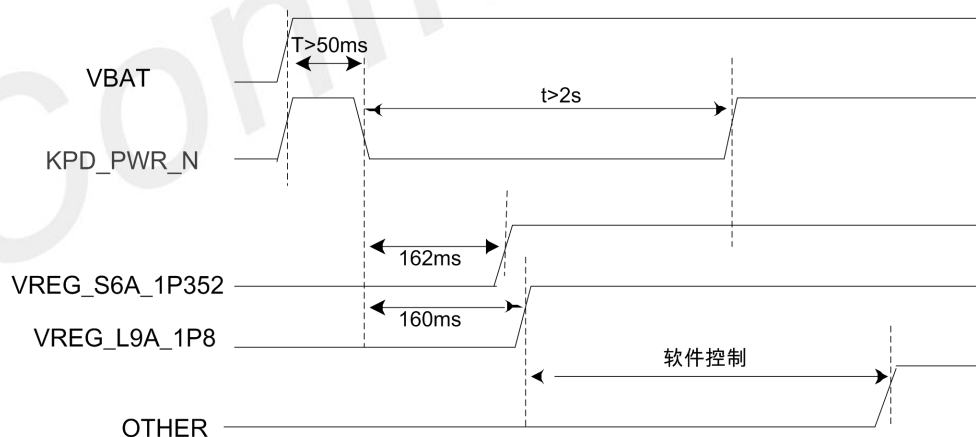

Figure 8: Power Sequence

NOTE

Highly recommend pulling down the KPD_PWR_N Pin when booting up the VBAT voltage at 3.8V stabilizing for at least 50ms. Do not pull down the KPD_PWR_N Pin all the time.

3.2.3 Power Off

Pull down the KPD_PWR_N Pin with at least 1s to power off the module. There is a pop up prompt window confirming the action of shutting down the device when the module detects the control instructions. Apart from that, pulling down the KPD_PWR_N Pin with over 8s would be forced restart the module.

Powering on and powering off are using the same pin, and they have the same reference design.

NOTE

1. The hardware design should cover the function of powering off the module. It is forbidden to run the module when powering off or restarting. Forced powering off the module adopts only when the module is running abnormally.
2. Highly recommend adding a low-cost microcontroller to control the KPD_PWR_N. Not only for the normal powering on and powering off but also for the watchdog function to protect the operation system.
3. Do not cut off the VBAT power supply directly when the module is running smoothly. It is to protect the internal flash memory.
4. Highly recommend to power off the module by the KPD_PWR_N Pin or the AT command before disconnecting the VBAT power supply.

3.3 Power On & Power Off

The VRTC is a standby power supply, connecting with a button battery or a large capacitor. VRTC would help to maintain the RTC timing when the VBAT is powering off. VRTC would also work as charging the button battery or a large capacitor when the VBAT is powering on.

- If the RTC fails, the RTC clock could be synchronized by connecting the data when the module is powering on.
- Please refer to the Table 8 for VRTC characteristics.
- The input voltage range for the VRTC voltage supply is 2.0V to 2.35V. The typical voltage is 3.0V. The average current consumption is 20uA when disconnecting the VBAT and connecting the RTC only.
- When powering on via the VBAT, the RTC working error is 50ppm. Switching the power supply mode of the VRTC Pin cause the RTC working error is 200ppm.
- Highly recommend the ESR of the button battery is less than 2K when connecting an external rechargeable button battery. Highly recommend to pick SEIKO's MS621FE FL11E.
- Highly recommend the ESR of the capacitor is 100uF when connecting an external large capacitor.

The reference designs for VRTC are showing below.

- **External Capacitor Power Supply for RTC**

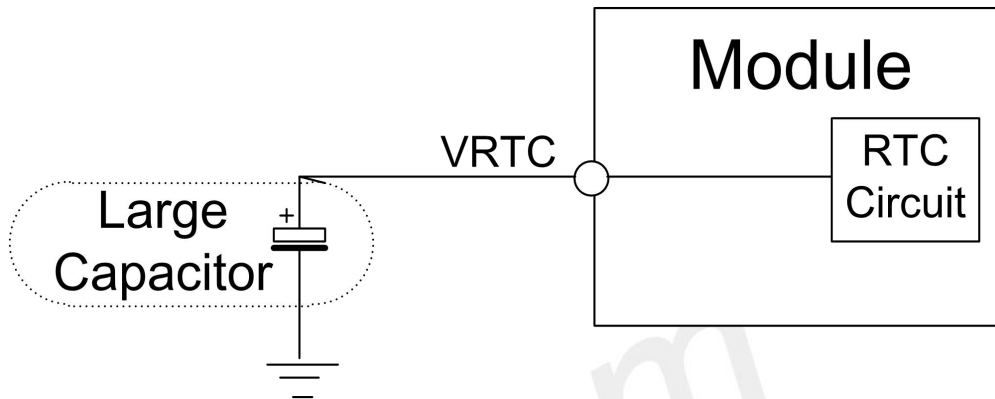

Figure 9: External Capacitor Power Supply for RTC

- **Non Rechargeable Battery Power Supply for RTC**

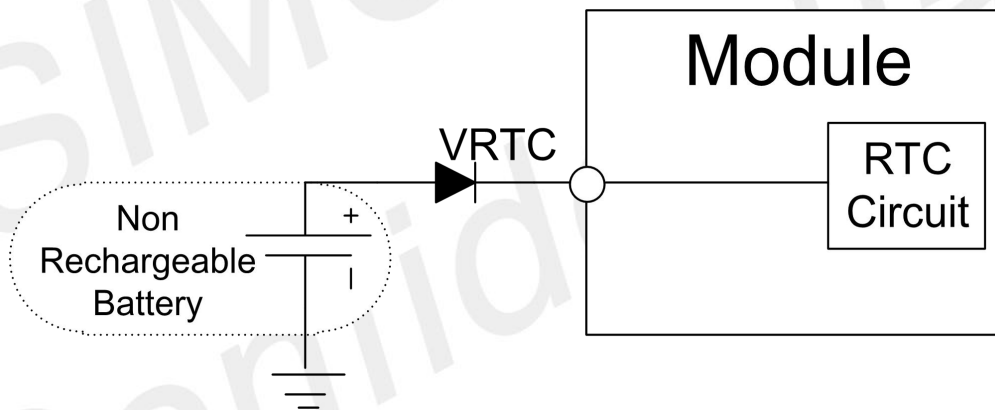

Figure 10: Non Rechargeable Battery Power Supply for RTC

- **Rechargeable Battery Power Supply for RTC**

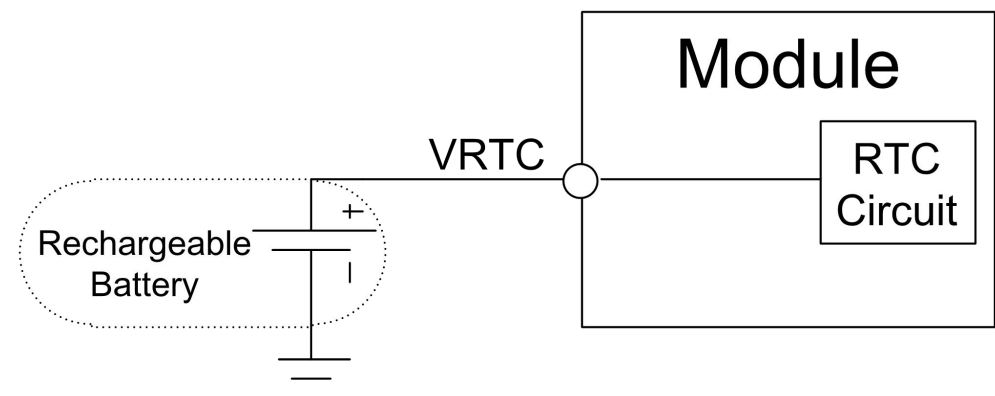

Figure 11: Rechargeable Battery Power Supply for RTC

The typical voltage of the VRTC is 3.0V. And the average current consumption is 20uA when disconnecting the VBAT and connecting the RTC only. The VRTC characteristics are showing in Table 8.

Table 8: VRTC Features

Parameters	Description	Minimum	Typical	Maximum	Unit
VRTC-IN	VRTC Input Voltage	2.0	3.0	3.25	V
T-series resistance	Standby Battery connecting in series resistor	800		2100	Ω
I _{RTC-IN}	VRTC Current Consumption (VBAT=0V)	-	20.0	-	μ A
VRTC-OUT	VRTC Output Voltage	2.5	3.1	3.2	V
I _{RTC-OUT}	VRTC Output Current	-		2	mA

NOTE

If the VBAT is connecting an external non-removable rechargeable battery, suspend the VRTC Pin. Also, the software should be modified to turn off the VRTC charging instructions.

3.4 Power Output

SIM8970x series module has 18 power outputs in total, which are suitable for a wide range of external interfaces and peripherals. Highly recommend a capacitor of 33pF and a capacitor of 10pF parallel connection to the ground, which could prevent high-frequency interference effectively.

Table 9: Power Definition

Power Name	PIN Num	Output Voltage (V)	Rated Current (mA)	Default On	Description
VPH_OUT	4	3.4-4.4	500	ON	Camera AVDD、AFVDD LDO, Connecting the VPH_OUT and the VPH_PWR internally
VREG_L12A_1P8	11	1.8	300	ON	Cameras and MIPI IOVDD(1.8V) Power
VREG_S6A_1P352	8	1.352	1200	ON	Camera DVDD LDO
VREG_L9A_1P8	10, 12	1.8	300	ON	External Power and External GPIO pull up and the 1.8V power

					level conversion
VREG_L14A_1P8	331	1.8	500	Off	Mainly for External Audio Codec Power
VREG_L19A_UIM1	211	1.8/2.95	150	Off	SIM Card1 Power
VREG_L20A_UIM2	172	1.8/2.95	150	Off	SIM Card2 Power
VREG_L5A_SDC2	80	1.8/2.95	50	Off	SDIO Pull up Power
VREG_L21A_2P704	5	2.704	500	Off	TP AVDD and LCD AVDD2.8V Power
VREG_L22A_2P96	149	2.96	600	Off	SD Card Power
VREG_L15A_3P128	345	3.128	150	ON	DP Switching Power
LCD_VSN	249	-5.4	80	Off	LCD VSN Power
LCD_VSP	250	+5.5	80	Off	LCD VSP Power
FLASH_LED1	305	-	1500	Off	FLASH 1 LED Power
FLASH_LED2	306	-	1500	Off	FLASH 2 LED Power
MIC_BIAS1	7	1.8	6	Off	Microphone Bias
MIC_BIAS3	235	1.8	6	Off	Headphone Microphone Bias
VPH_PWR	285 286 287	-	2000	Lowered	Output Power by the VBAT or the VBUS for external peripherals

3.5 Charging and Battery Management

SIM8970x series module supports the Qualcomm Quick Charge (QC) 2.0 and 3.0 fast charging protocol. The maximum current of the QC3.0 protocol is up to 3A, and the charging power is about 15W to 18W. The module integrates the internal charging temperature rising control function. Decreasing the charging voltage and the charging current happens automatically when the temperature is too high.

Table 10: Comparison of the Charge Protocol

Charge Protocol	DP Vol.	DM Vol.	Charge Voltage	Charge Current	Charge Power	Connector	Description
QC2.0	0.6V	0.6V	12V	1.5-2A	> 7.5 W	Type-C Micro-USB	Higher charging voltage, Lower charging efficiency, Higher charging heat, Charging over 9V works improperly.
	3.3V	0.6V	9V				
	0.6V	GND	Default 5V				
QC3.0	0.6V	3.3V	Continuo	3A	≥ 18 W	Type-C	Adopts INOV

		us Mode 3.6-12V		Micro-USB	Algorithm, Adjustable with 200mV for Charging, Higher charging efficiency, Higher charging speed, Lower charging heat.
--	--	--------------------	--	-----------	--

SIM8970x series module could charge the battery. It supports several charging modes, including the trickle charging mode, the pre-charging mode, the constant current charging mode, and the other charging modes.

- **The Trickle Charging Mode:**
The system is running into the trickle charging mode when the voltage of the battery is lower than 2.1V. In this case, the charging current is about 75mA.
- **The Pre-charging Mode:**
The system is running into the pre-charging mode when the voltage of the battery is between 2.1V and 3.0V (The cut-off voltage is programmable between 2.4V and 3.0V, Default 3.0V). The charging current is about 300mA (The current is programmable between 100mA and 450mA, Default 300mA).
- **The Constant Current Charging Mode:**
The system is running into the constant current charging mode when the voltage of the battery is between the cut-off voltage of the pre-charging mode and 4.2V (The voltage is programmable between 3.6V and 4.2V, Default 4.2V). The charging current is programmable between 300mA and 3000mA (The Default USB charging current is setting at 500mA in the software configuration).
- **The Constant Voltage Charging Mode:**
The system is running into the constant voltage charging mode when the voltage of the battery is reaching at 4.2V. In this case, the charging current is decreasing gradually. The charging status would stop when the charging current is reaching at 100mA.

Table 11: The Battery's Pin Definition

PIN Name	PIN Num	I/O	Description	Note
VBAT	83 84 85	PI/ PO	Module Power Input, Battery Charge Output	
BATT_ID	332	AI	Battery Detection	Highly recommend an external 100KR resistor connecting to the ground when no battery ID.
BATT_THERM	333	AI	Battery Thermal Detection	Connect to the battery NTC Resistor, Highly recommend an external 47KR resistor connecting to the ground when no battery.
VBATT_SNS_P	339	AI	Battery Voltage Detection +	Connect
VBATT_SNS_M	340	AI	Battery Voltage Detection -	Connect

SIM8970x series module has the function of battery detection. Generally, there is a BATT_ID Pin in the battery. Highly recommend an external 100KR resistor (R2) connecting to the ground when the battery has no BATT_ID. Avoid suspend.

SIM8970x series module has the function of battery temperature detection. This function requires an integrated thermistor in the battery (Recommend a 47KR \pm 1% NTC Resistor). And the NTC resistor needs to connect to the BATT_THERM Pin. The module would charge fail when suspending the BATT_THERM pin. Highly recommend the R2=100KR and the R3=47KR when there is no BATT_ID and BATT_THERM. In this case, the module would power on by the adapter.

SIM8970x series module has the function of battery's fuel gauge. It estimates the real-time power of the battery accurately. Not only protect the battery and prevent the over dis-charge but also help the users to estimate the entertainment time and save the important data. For different types of batteries, modifying the software settings enables the designated battery working properly.

The VBATT_SNS_P Pin and the VBATT_SNS_M Pin must be connected whether the module is powering on by a battery or a stable power supply. The module would not work well if suspending these two pins. These two pins are for battery voltage detection. Differential pair routing and stereo ground plane are needed.

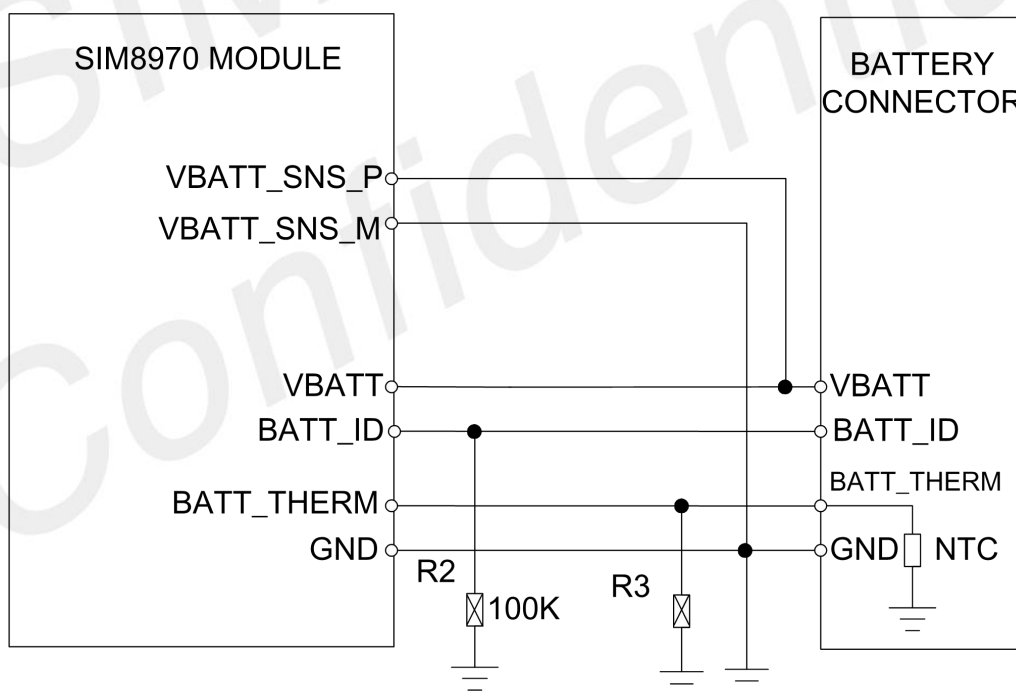

Figure 12: Battery Connection Reference Design

3.6 USB Interface

3.6.1 Micro-USB Interface and Type-C Interface

SIM8970x series module supports a USB interface, complying with USB 3.1/2.0 protocol and supporting USB OTG. The highest speed for the USB3.1 is up to 10Gbps, and for the USB 2.0 is up to 480Mbps. It is downward compatible with full speed (12Mbps) mode. USB_HS interface supports the function of the AT command transmission, of the data transmission, of the software debugging, and of the software upgrading.

SIM8970x series module only supports Micro-USB or Type-C at one time due to different protocols. If the hardware configuration is connecting with Type-C, but the physical channel is running through the Micro-USB interface, the USB identification would run timeout.

Table 12: The Interface Configuration of the Micro-USB or the Type-C

PIN Name	PIN Num	Micro-USB	Type-C
USB_PHY_PS	282	Float	Connect to PIN 267
CPU_USB_PHY_PS	267	10K Pull down to the Ground	Connect to PIN 282

- The Type-C Interface Reference Design

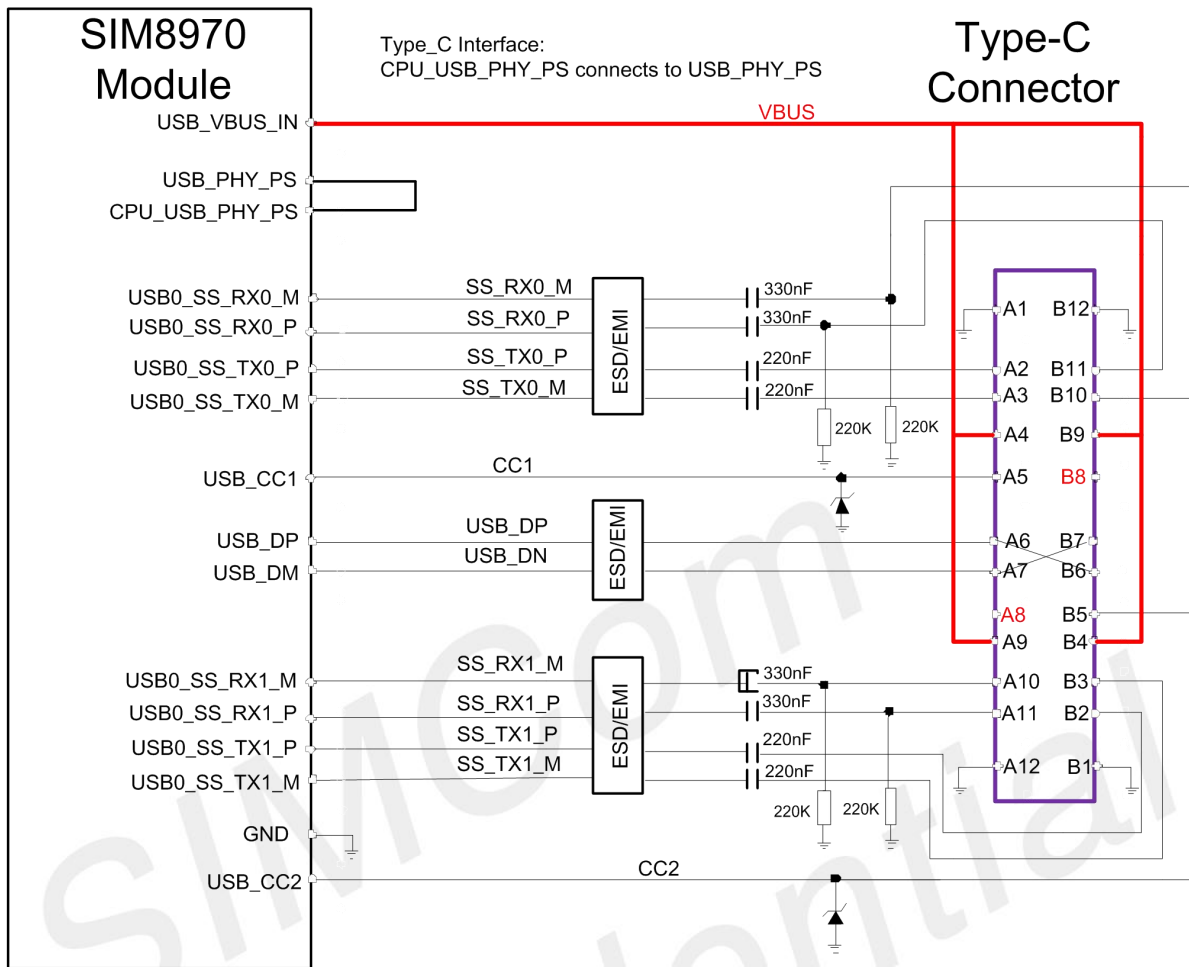

Figure 13: USB Type-C Connection Reference Design

- The Micro-USB Interface Reference Design

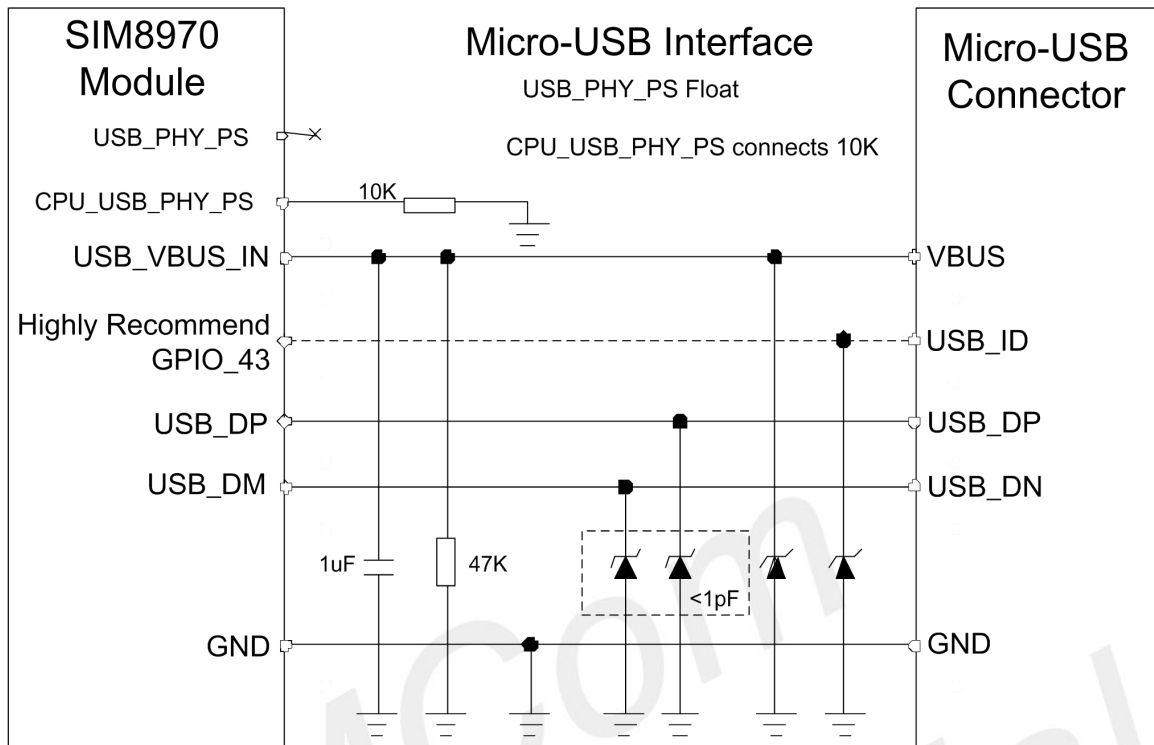

Figure 14: USB Micro-USB Connection Reference Design

3.6.2 Micro-USB Interface and Type-C Interface Feature

Table 13: DP and USB3.1 Type-C Compatible Pin Definition

PIN Name	PIN Num	USB Mode	Display Port Mode
USB0_SS_RX0_P/M	193/194	USB0_SS_RX0_P/M	DP_LANE3_P/M
USB0_SS_TX0_P/M	196/197	USB0_SS_TX0_P/M	DP_LANE2_P/M
USB0_SS_RX1_P/M	324/323	USB0_SS_RX1_P/M	DP_LANE0_P/M
USB0_SS_TX1_P/M	325/326	USB0_SS_TX1_P/M	DP_LANE1_P/M
USB0_DP_AUX_P/M	321/320	SBU1/2	USB0_DP_AUX_P/M
USB_DP/M	146/147	USB_DP/M	USB1_HS_DP/M
USB_CC1/USB_CC2	191/190	CC/VCONN	HOTPLUG_DET/ VCONN
USB_VBUS_IN	87/288/289	VBUS	VBUS

SIM8970x series module supports the 4-Lane DP interface, and it supports 1920X1200 displaying screen. Apart from that, it shares functional pins with the USB3.1 Type-C interface.

USB Mode: USB mode and DP mode could not work at the same time.

DP Mode: DP and USB2.0 could work properly at the same time. But not for the USB3.1. For the DP

interface, the USB0_DP_AUX_P pin and the USB0_DP_AUX_M pin are needed in addition to the USB3.1 compatible pins.

Highly recommend disconnect the Type-C interface and the DP_AUX_P/N signals when running with the USB function. A switch is needed in this case. The switch is closing by default. The DP_EN_N output is active low when switching into the DP interface. The USBC_ORIENTAION output is active high when switching into the MHL channel.

- **The Type-C Interface with DP Function Reference Design**

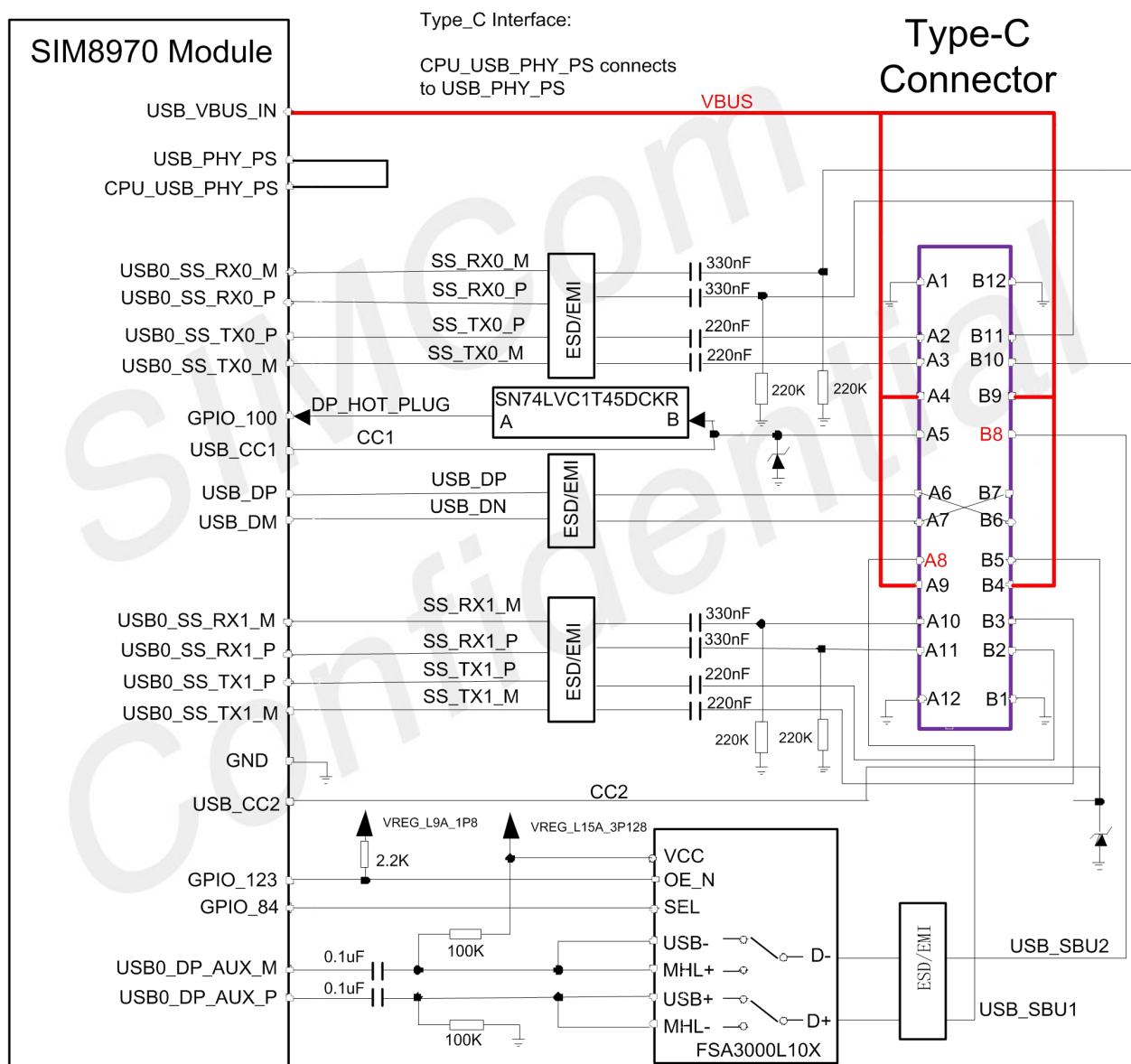

Figure 15: USB Type-C with DP Function Connection Reference Design

PCB wiring protocols and hardware design notices for USB signals are listing below.

- Differential pair routing, 90+-10% impedance control, and stereo ground plane are needed.
- Reserved ESD protection components close to the USB interface:
Highly recommend the TVS junction capacitance value on the USB2.0 signal lines less than 2pF.
Highly recommend the TVS junction capacitance value on the USB3.1 signal lines less than 0.5pF.

- Do not wiring the USB signals under the crystal oscillator, the oscillator, the magnetic devices, and the RF signals. Highly recommend routing in the inner layer and stereo ground plane.
- Highly recommend the USB2.0 signals, the USB3.1 TX signals, and the USB 3.1 RX signals are wiring as differential pairs separately. For DP displaying function, highly recommend the USB3.1 TX signals, the USB 3.1 RX signals, and the DP_AUX signals are wiring as differential pairs separately.

3.7 UART/SPI/I2C/I2S Interface

SIM8970x series module supports multiple sets of the UART, the I2C, the SPI, and the I2S. The combination of multiple interfaces is flexible and achievable by the configuration of GPIOs. The interface voltage is 1.8V.

3.7.1 UART/SPI/I2C Interface Multiplexing

Table 14: UART/SPI/I2C Interface Multiplexing Feature

Set	PIN Name	PIN Num	GPIO	Multiplex1 SPI	Multiplex2 UART	Multiplex3 I2C/I3C
1	GPIO_0	51	GPIO_0	SPI1_MISO	UART1_CTS	I2C1_SDA
	GPIO_1	52	GPIO_1	SPI1_MOSI	UART1_RTS	I2C1_SCL
	GPIO_2	26	GPIO_2	SPI1_CLK	UART1_TX	
	GPIO_3	25	GPIO_3	SPI1_CS_N	UART1_RX	
2	APPS_I2C_SDA	251	GPIO_4			APPS_I2C_SDA
	APPS_I2C_SCL	252	GPIO_5			APPS_I2C_SCL
3	TP_I2C_SDA	167	GPIO_6	SPI2_MISO	UART2_CTS	TP_I2C_SDA
	TP_I2C_SCL	117	GPIO_7	SPI2_MOSI	UART2_RTS	TP_I2C_SCL
	GPIO_8	69	GPIO_8	SPI2_CLK	UART2_TX	
	GPIO_9	71	GPIO_9	SPI2_CS_N	UART2_RX	
4	GPIO_14	78	GPIO_14		UART3_TX	I2C3_SDA
	GPIO_15	77	GPIO_15		UART3_RX	I2C3_SCL
5	DEBUG_UART_TX	37	GPIO_16		DEBUG_UART_TX	I2C4_SDA
	DEBUG_UART_RX	36	GPIO_17		DEBUG_UART_RX	I2C4_SCL
6	SNSR_I3C_SDA	72	GPIO_22	SPI3_MISO	UART4_CTS	SNSR_I3C_SDA
	SNSR_I3C_SCL	73	GPIO_23	SPI3_MOSI	UART4_RTS	SNSR_I3C_SCL
	GPIO_24	182	GPIO_24	SPI3_CLK	UART4_TX	
	GPIO_25	183	GPIO_25	SPI3_CS_N	UART4_RX	
7	SENSOR_I2C_SDA	39	GPIO_28			SENSOR_I2C_SDA

	SENSOR_I2C_SCL	38	GPIO_29			SENSOR_I2C_SCL
8	GPIO_30	46	GPIO_30	SPI4_MISO	UART5_CTS	I2C5_SDA
	GPIO_31	45	GPIO_31	SPI4_MOSI	UART5_RTS	I2C5_SCL
	GPIO_32	47	GPIO_32	SPI4_CLK	UART5_TX	
	GPIO_33	89	GPIO_33	SPI4_CS_N	UART5_RX	
	CAM_I2C0_SDA	94	GPIO_37			CCI_I2C_SDA0
	CAM_I2C0_SCL	95	GPIO_38			CCI_I2C_SCL0
	CAM_I2C1_SDA	54	GPIO_39			CCI_I2C_SDA1
	CAM_I2C1_SCL	55	GPIO_40			CCI_I2C_SCL1

- SIM8970x series module defines the default configuration for these pins highlighting in green. Please consult SIMCom staff to review the reference design and functions for these pins.
- SIM8970x series module supports 4 sets of SPI, 6 sets of UART, and 8 sets of I2C (excluding camera's I2C). Choosing only one function among the SPI, the UART, and the I2C in the same bus set. For example, the I2C5 and the UART5 (TX/RX) could not function well at the same time.
- Highly recommend an external 2.2K Ω resistor pulling up to the 1.8V power supply for I2C.
- Do not reuse the Debug GPIO16 and GPIO17.
- SPI interface could support the working frequency up to 50MHz.

3.7.2 UART Voltage Level Switch Circuit

SIM8970x series module supports up to 6 sets of the UART interfaces, including the 2 sets of the 2-Lane interface, and the Debug UART for debugging. The other 4 sets of the 4-Lane interface support the hardware flow control with the highest speed up to 4Mbps. The interface voltage for UART on the SIM8970x series module is 1.8V. Taking a voltage level switch chip for voltage switching if needed. Highly recommend pick TI's TXS0104EPWR, and the reference design is showing in the following Figures.

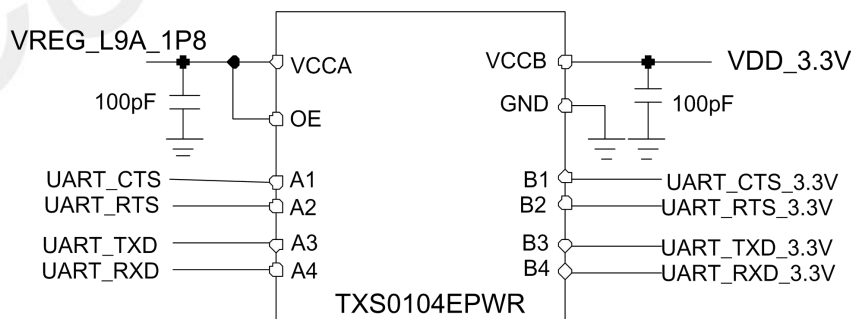

Figure 16: UART Voltage Level Switch Reference Design

The compatible reference design is showing below.

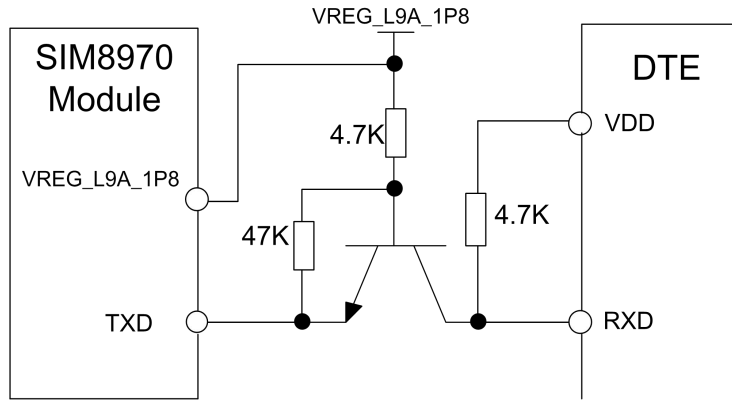

Figure 17: TX Voltage Level Switch Reference Design

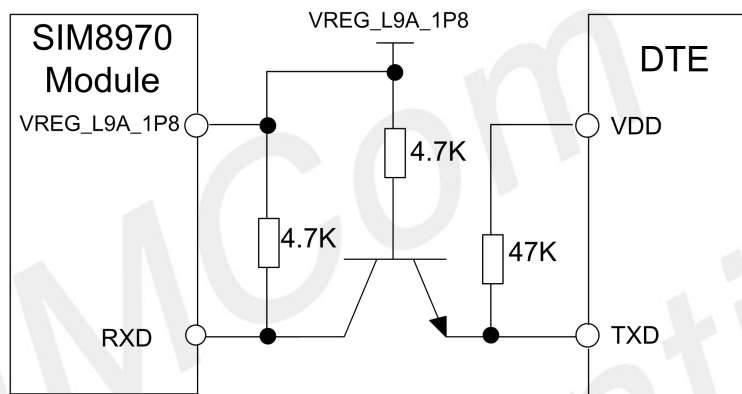

Figure 18: RX Voltage Level Switch Reference Design

3.7.3 SPI Interface

SIM8970x series module supports up to 4 sets of the SPI interfaces. They only support the host mode, and the highest working frequency is 50MHz.

Table 15: Recommend SPI Interface

PIN Name	PIN Num	I/O	Description	Notes
GPIO_0	51	DI	SPI Data Input Signal	
GPIO_1	52	DO	SPI Data Output Signal	
GPIO_2	26	DO	SPI Chip Select Signal	
GPIO_3	25	DO	SPI Clock Signal	
GPIO_30	46	DI	SPI Data Input Signal	
GPIO_31	45	DO	SPI Data Output Signal	
GPIO_32	47	DO	SPI Clock Signal	
GPIO_33	89	DO	SPI Chip Select Signal	

3.7.4 I2C Interface

SIM8970x series module supports up to 8 sets of the I2C interfaces, but only open the following 6 sets of the I2C interfaces by default. They only support the host mode, and the highest speed is 400Kbps. Highly recommend an external 2.2K Ω resistor pulling up to the 1.8V power supply for I2C.

Table 16: Recommend I2C Interface

PIN Name	PIN Num	I/O	Pull Up Voltage	Description	Notes
APPS_I2C_SDA	251	DI/DO	VREG_L9A_1P8	Default External I2C Data Signal	For External PD Interface
APPS_I2C_SCL	252	DO	VREG_L9A_1P8	Default External I2C Clock Signal	
TP_I2C_SDA	167	DI/DO	VREG_L9A_1P8	TP1 I2C Data Signal	For TP
TP_I2C_SCL	117	DO	VREG_L9A_1P8	TP1 I2C Clock Signal	
SNSR_I3C_SDA	72	DI/DO	VREG_L9A_1P8	Sensor I3C Data	For Sensors
SNSR_I3C_SCL	73	DO	VREG_L9A_1P8	Sensor I3C Clock	
CAM_I2C0_SDA	94	DI/DO	VREG_L12A_1P8	Camera I2C Data	For Cameras
CAM_I2C0_SCL	95	DO	VREG_L12A_1P8	Camera I2C Clock	
CAM_I2C1_SDA	54	DI/DO	VREG_L12A_1P8	Camera I2C Data	For Cameras
CAM_I2C1_SCL	55	DO	VREG_L12A_1P8	Camera I2C Clock	
SENSOR_I2C_SDA	39	DI/DO	VREG_L9A_1P8	External Sensor I2C Data	For External Sensors
SENSOR_I2C_SCL	38	DO	VREG_L9A_1P8	External Sensor I2C Clock	

3.7.5 I2S Interface

SIM8970x series module supports 2 sets of the I2S interfaces. It supports the input- mode, the output-mode, and the host-/device-mode. The definition is showing in Table 17.

Table 17: Recommend I2S Interface

PIN Name	PIN Num	Multiplex I2S	I/O	Description	Notes
DMIC1_CLK	309	MI2S1_SCK	DI/DO	I2S2 Clock	Occupy when select 2
DMIC1_DATA	310	MI2S1_WS	DI/DO	I2S2 Word Select	
DMIC2_CLK	311	MI2S1_DATA0	DI/DO	I2S2 Data0	LCDs
DMIC2_DATA	312	MI2S1_DATA1	DI/DO	I2S2 Data1	

GPIO_113_PRI_MI2S_SCK	62	PRI_MI2S_SCK	DI/DO	PRI_MI2S Clock
GPIO_114_PRI_MI2S_WS	63	PRI_MI2S_WS	DI/DO	PRI_MI2S Word Select
GPIO_115_PRI_MI2S_DATA0	64	PRI_MI2S_DATA0	DI/DO	PRI_MI2S Data0
GPIO_116_PRI_MI2S_DATA1	65	PRI_MI2S_DATA1	DI/DO	PRI_MI2S Data1

3.8 SD Card Interface

SIM8970x series module supports SD 3.0/MMC cards with 4-Bit data interface or SDIO 3.0 devices. The SD cards comply with the following protocols.

- SD Specifications Part 1 Physical Layer Specification Version 3.00
- Part A2 SD Host Controller Standard Specification Version 3.00
- Part E1 SDIO Specification Version 3.00

The reference design for SD card is showing in the Figure 19.

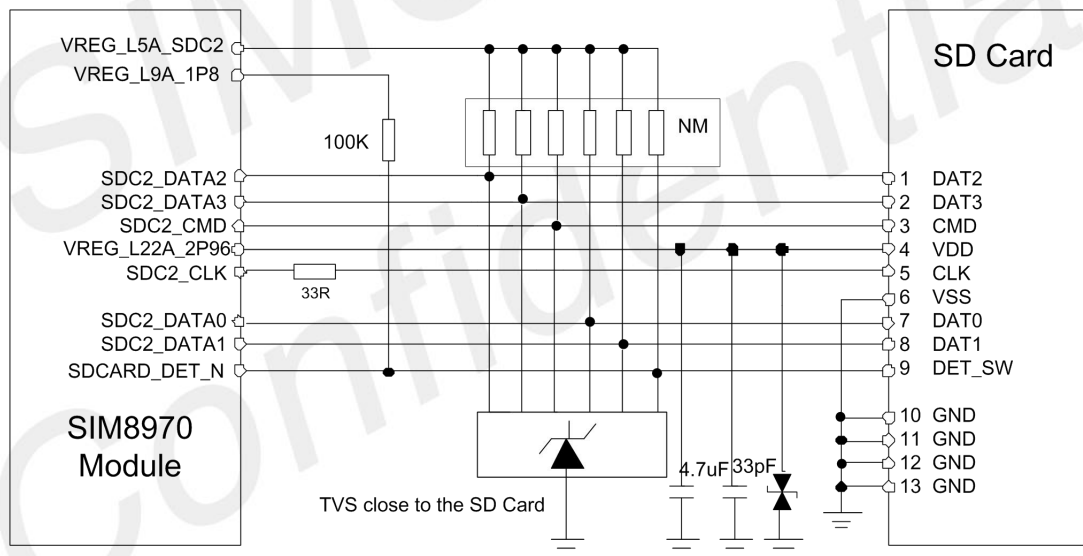

Figure 19: SD Card Reference Design

NOTE

VREG_L22A_2P96 is a fixed 2.96V power output.
Highly recommend avoiding pull up the SDC2 signal lines to the VREG_L22A_2P96.
Refer to chapter 4 for PCB design rules.

3.9 TP Interface

SIM8970x series module provides an I2C interface, an interruption function pin, and a reset pin, connecting the touching panel to operate.

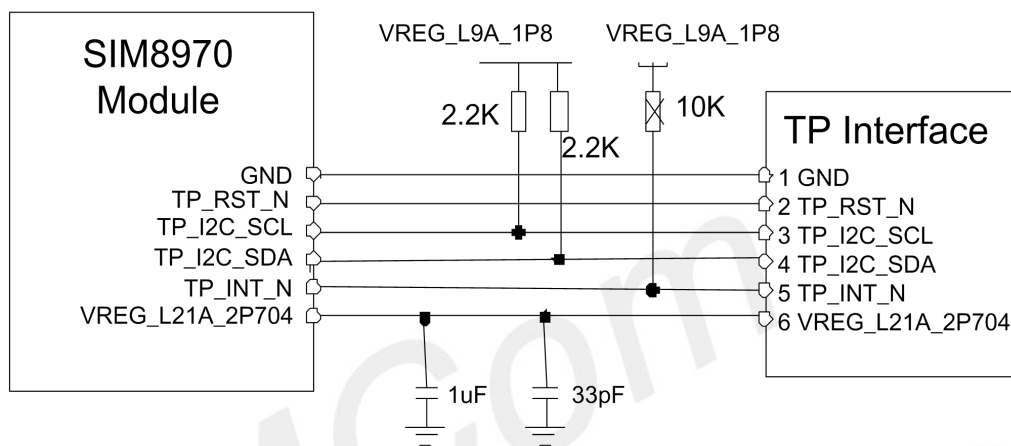

Figure 20: TP Interface Reference Design

NOTE

Highly recommend an external 2.2KR resister pulling up to the 1.8V power supply for TP I2C.

3.10 LCD Interface

SIM8970x series module's video output interface meets the requirements of MIPI_DSI standard. It has a 4-Lane DSI DPHY 1.2 interface with the speed up to 1.5Gbps. It also supports dual screen display with the maximum resolution of 2520*1080 (FHD+). Apart from that, the SIM8970x series module supports displaying screen with display port protocol via the USB Type-C interface.

The PWM1 pin of the module could control the backlight brightness by software configuration.

The MIPI signal lines are high-speed signal lines. Highly recommend place a common mode inductor close to the LCM to avoiding EMI interference. Suspend the MIPI_Lane2 and the MIPI_Lane3 when the LCM only has 2-Lane differential pair data signals. Highly recommend adopting the module's integrated reference circuits if the LCD interface has no bias voltage hardware design. Notice that the positive bias voltage and the negative bias voltage of the LCD are between the LCD_VSN and the LCD_VSP of the module. The reference design is showing in the Figure 21.

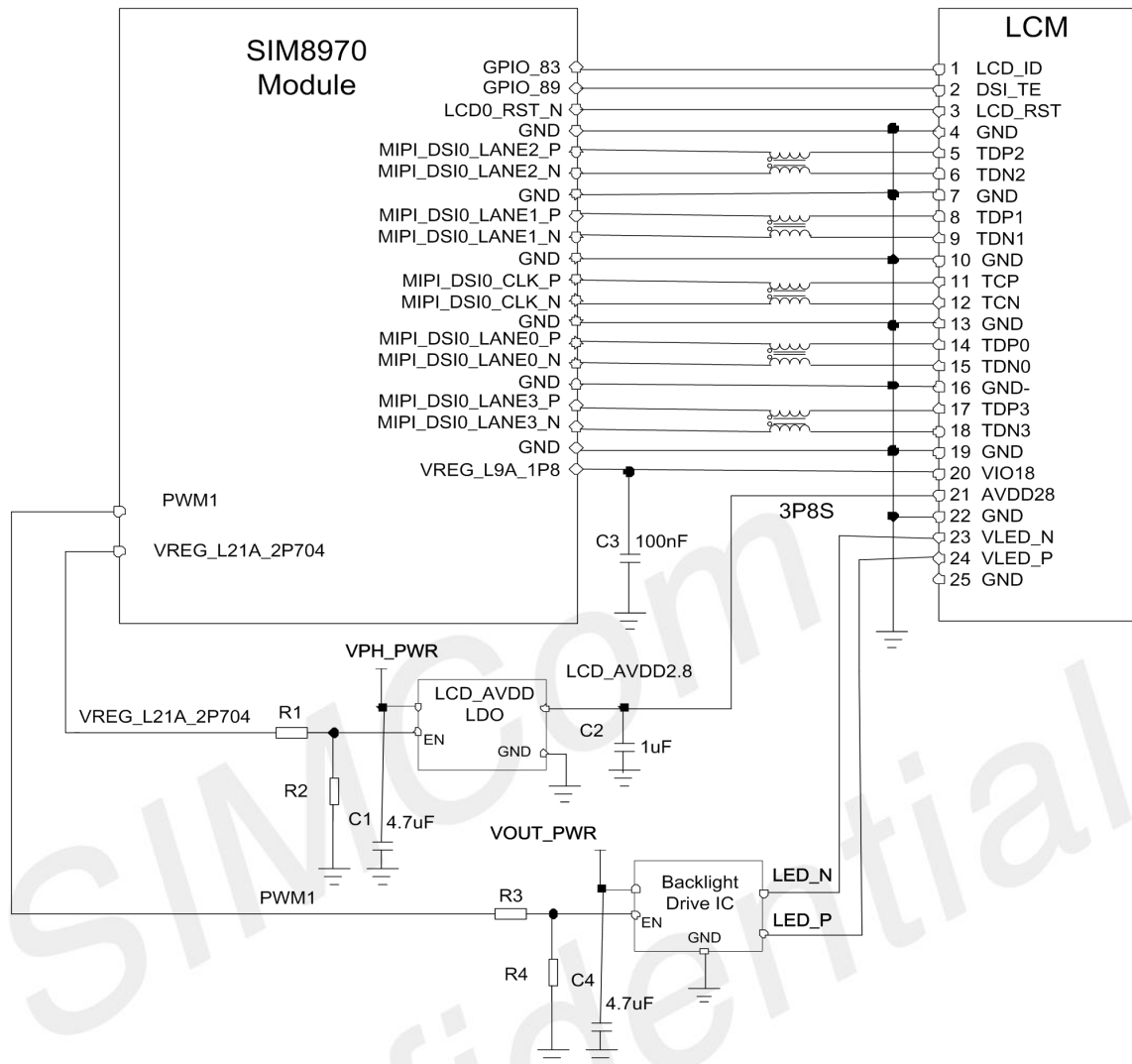

Figure 21: LCD Interface & the Backlight Reference Design

3.11 Camera Interface

SIM8970x series module's video input interface meets the requirements of MIPI_CSI standard.

- 3 sets of 4-Lane CSI interfaces.
Support 3 (4-Lane + 4-Lane + 4-Lane) cameras or
Support 4 (4-Lane + 4-Lane + 2-Lane + 1-Lane) cameras.
- Selectable on in the following two settings.
Support DPHY 1.2 with the speed up to 1.5Gbps/Lane or
Support CPHY 1.0 with the speed up to 10.26Gbps(total).
- Support dual image signal processing (ISP) with the largest resolution up to 25M pixels (dual ISP).
The maximum capacity of each ISP is 16M pixels. Only support one when the ISP is over 16M pixels.
- Support 4-Lane MCLKs, 2-Lane CCI I2C interfaces, and the GPIOs with different functions.

3.11.1 CPHY & DPHY Interface of the Cameras

SIM8970x series module supports CPHY 1.0. The difference between the CPHY and the DPHY are the different effective transmission mode. CPHY enables the data transmission speed faster through the following technical improvements. Firstly, CPHY converts the original 2-Lane group transmission of DPHY into 3-Lane group transmission. Then, CPHY does not need the Clock lane. The two are compatible in pin definitions. Detailed information is showing in Table 18.

Figure 22 shows the application diagram of the CSI interface. It is a combination configuration, including 4 DPHY sensors, 3 CPHY sensors, a DPHY sensor, and a CPHY sensor. Note that CSI2 could be split into two cameras (2-Lane + 1-Lane or 1-Lane + 1-Lane). The following applications are flexible.

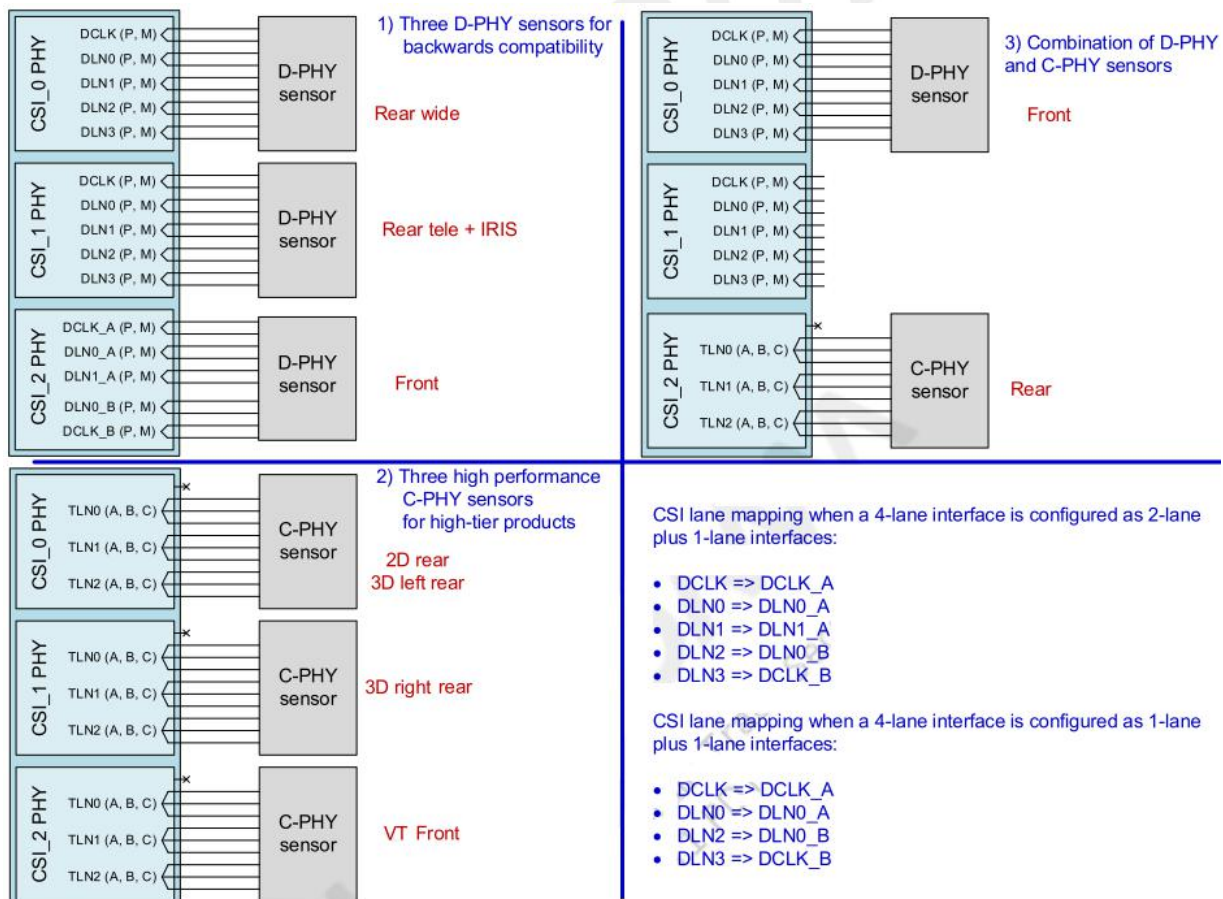

Figure 22: CPHY & DPHY Interface Applications

Table 18: DPHY & CPHY PIN Definition

CSIx PHY (1 of 3)	DPHY	CPHY
Lane0	MIPI_CSIX_DCLK_P	/
	MIPI_CSIX_DCLK_N	MIPI_CSIX_TLN0_A
Lane1	MIPI_CSIX_DLN0_P	MIPI_CSIX_TLN0_B

	MIPI_CSIX_DLN0_N	MIPI_CSIX_TLN0_C
Lane2	MIPI_CSIX_DLN1_P	MIPI_CSIX_TLN1_A
	MIPI_CSIX_DLN1_N	MIPI_CSIX_TLN1_B
Lane3	MIPI_CSIX_DLN2_P	MIPI_CSIX_TLN1_C
	MIPI_CSIX_DLN2_N	MIPI_CSIX_TLN2_A
Lane4	MIPI_CSIX_DLN3_P	MIPI_CSIX_TLN2_B
	MIPI_CSIX_DLN3_N	MIPI_CSIX_TLN2_C

3.11.2 DPHY Applications

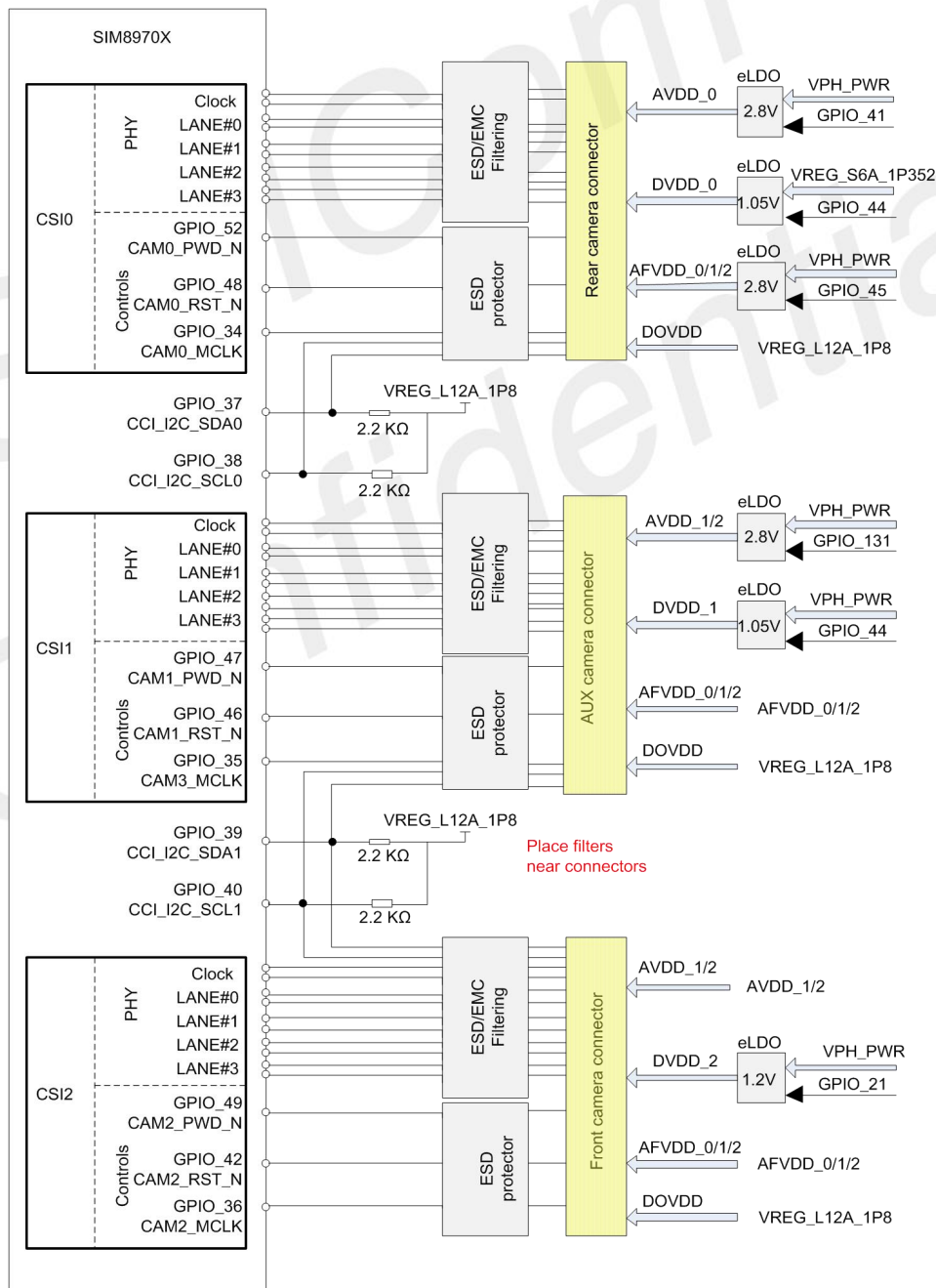

Figure 23: Three sets of MIPI-CSI Interface Applications

3.12 Audio Interface

SIM8970x series module supports three analog audio inputs, including the MIC1 differential pair interface for the master microphone, the MIC3 differential pair interface for the denoising microphone, and the MIC2 single ended interface for the audio jack.

- Three-Channel analog audio output interface.
Handset.
Speaker.
Stereo Headphone and LINEOUT.
- Two-Channel digital microphone interface.
Support 4 digital microphones.

3.12.1 Microphone Interface

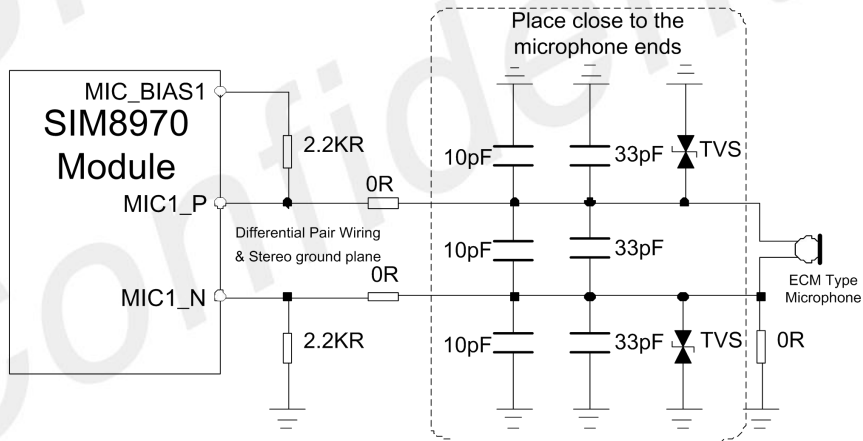

Figure 24: ECM Type Microphone Reference Design

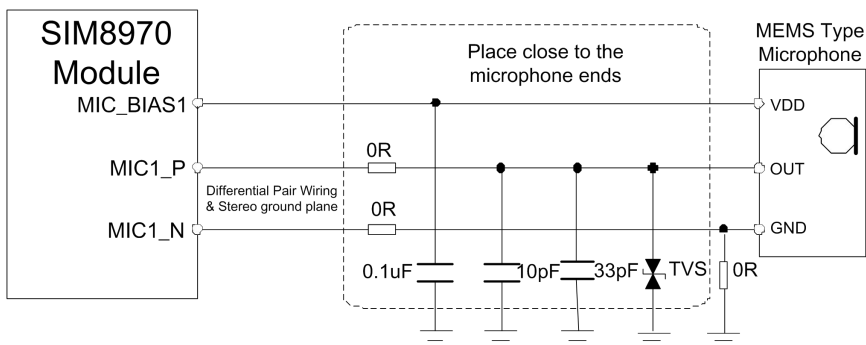

Figure 25: MEMS Type Microphone Reference Design

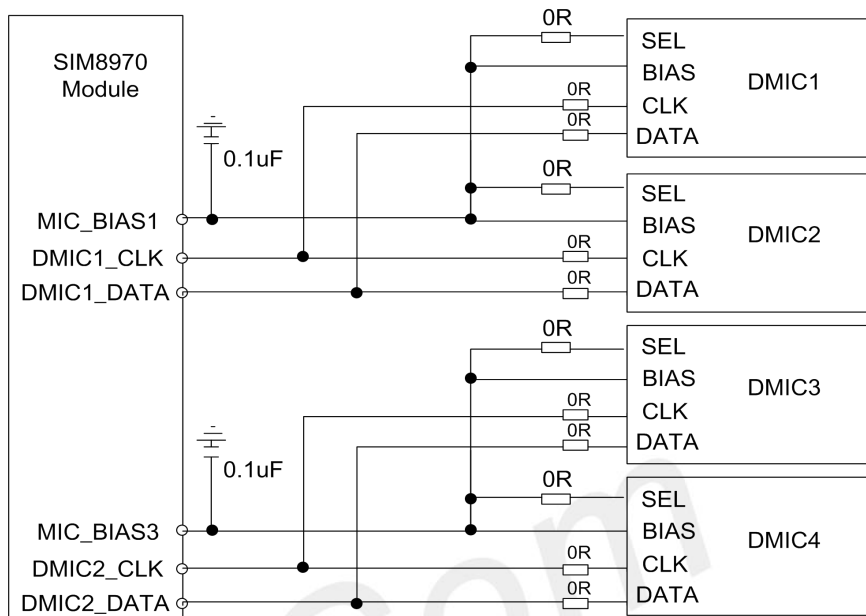

Figure 26: Digital Microphone Reference Design

3.12.2 Headphone Interface

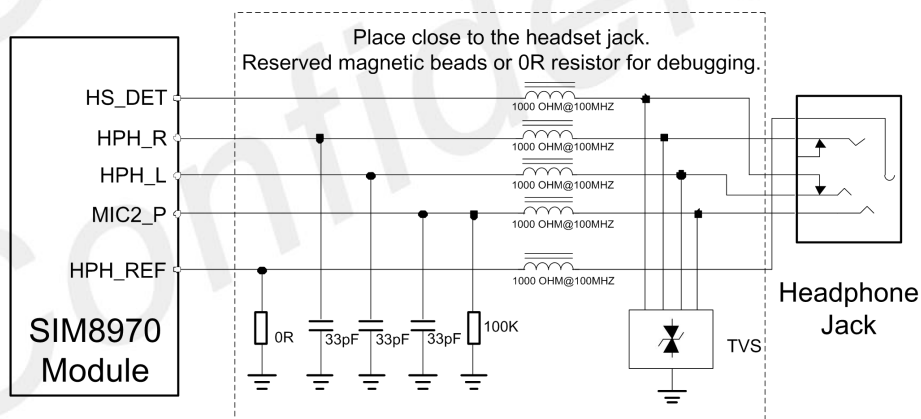

Figure 27: Headphone Reference Design

NOTE

1. The reference design for headphone in the Figure 27 is working actively high. The software detection mode configuration changes if the customers are picking an audio working actively low.
2. Highly recommend the HS_DET and the HPH_L form a detection loop, and the HPH_L has an internal 100KR resistor pulling down to the ground. The HS_DET is connecting to the HPH_L presenting actively low when disconnecting the headphone. The HS_DET and the HPH_L are disconnecting presenting actively high when inserting the headphone.
3. Picking a bidirectional TVS on the network due to the negative voltage on the HPH signal.

Table 19: Headphone Output Feature

Parameter	Testing Condition	Minimum	Typical	Maximum	Unit
Output Power	Input = 0 dBFS	27	30	-	mW
Output Voltage	Input = 0 dBFS	0.94	0.99	-	Vrms
Loads		4	32	-	Ω
Off Impedance		-	20	-	Ω

3.12.3 Speaker Interface

SIM8970x series module integrates a Class-D Type audio power amplifier (PA) internally. The PA integrates an internal SPKR_BOOST (Maximum Output Voltage 5.5V) circuit. The audio PA feature is listing in Table 20, and the reference design for the speaker interface is showing in the Figure 28.

Table 20: Audio PA Feature

Parameter	Testing Condition	Minimum	Typical	Maximum	Unit
Power (f = 1 kHz, THD+N \leq 1%)	15 μ H + 4 Ω + 15 μ H, VDD_SPKR = 7.5V	-	4000	-	mW
	15 μ H + 8 Ω + 15 μ H, VDD_SPKR = 9 V	-	4000	-	mW
SNR	A-weighted, DRE on, 15 dB gain, 0 dBFS input, 300 kHz carrier frequency, VBAT \geq 3.6 V	109	112		dB
	A-weighted, DRE on, 15 dB gain, 0 dBFS input, 600 kHz carrier frequency, VBAT \geq 3.6 V	111	114	-	dB
Efficiency	4W Pout, 15 μ H + 8 Ω + 15 μ H	87.0	87.0	-	%
	4W Pout, 15 μ H + 4 Ω + 15 μ H	83.5.0	84.5	-	%
Off Impedance		25	-	-	k Ω
Loads		3.2	-	-	Ω

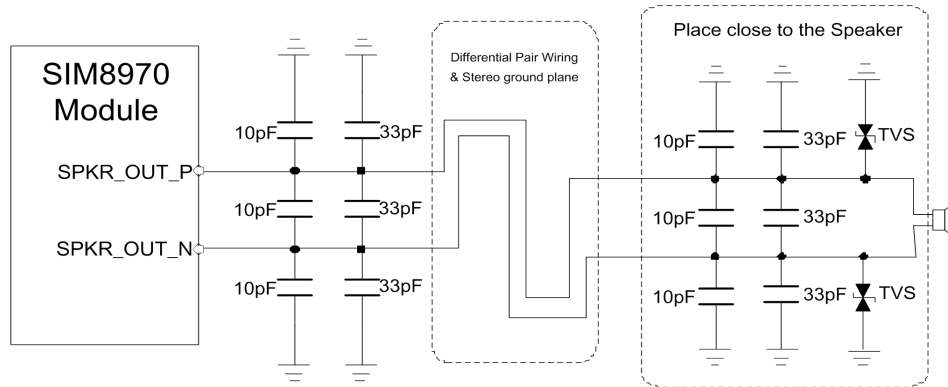

Figure 28: Speaker Reference Design

3.12.4 Handset Interface

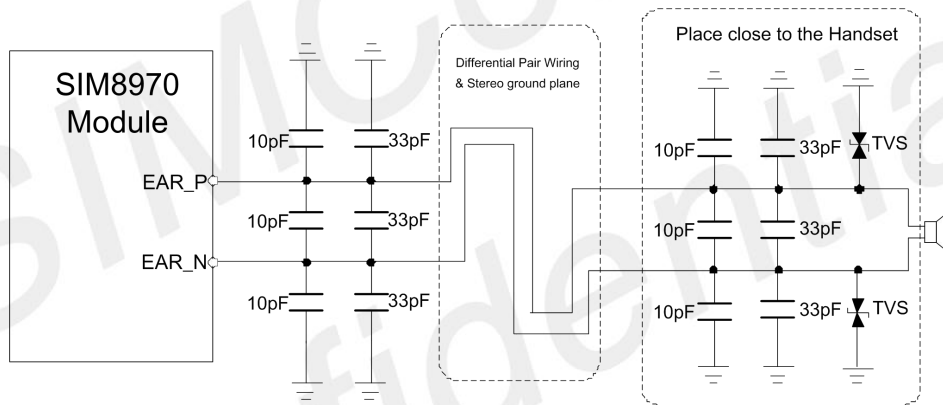

Figure 29: Handset Reference Design

Table 21: Handset Output Feature

Parameter	Testing Condition	Minimum	Typical	Maximum	Unit
Output Power	PA gain = 6 dB, 32 Ω , THD+N \leq 1%	115	123	-	mW
	PA gain = 6 dB, 10.67 Ω , THD+N \leq 1%	150	-	-	mW
Output Voltage	Input = 0 dBFS, PA gain = 6 dB	1.93	1.97	-	Vrms
Loads		10.67	32	-	Ω

3.13 UIM Card Interface

SIM8970x series module offers two UIM Cards interface, supporting dual card dual standby. The UIM Cards

interface also supports the 1.8V/2.95V dual voltage and the hot-join detect function.

NOTE

The standard software version supports dual cards, and the single card function needs to be supported by the special software version.

The reference design for the UIM Card is showing in the Figure 30.

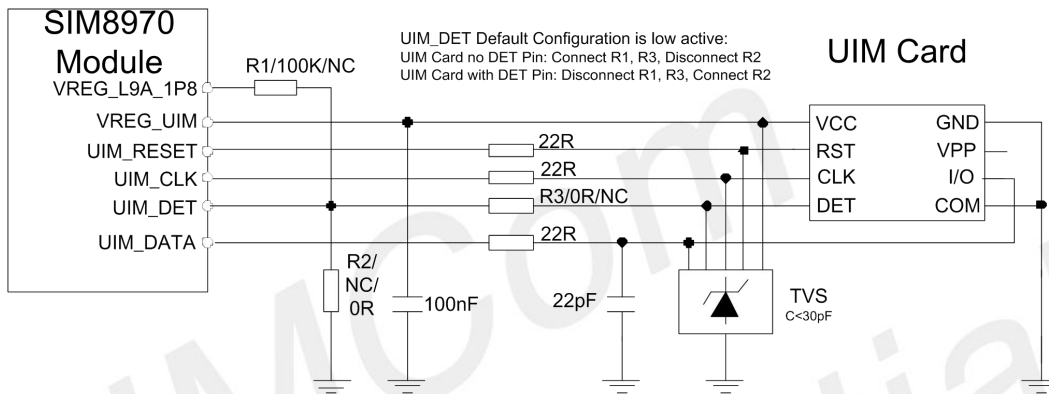

Figure 30: UIM Card Interface Reference Design

NOTE

1. The UIM_DATA Pin of the module pulls up to the VREG_UIM internally. Avoid external pull up.
2. Place the TVS close to the UIM Card receptacle interface.
3. Highly recommend the parasitic capacitance of the TVS on the UIM_CLK should be less than 30pF.
4. Highly recommend the 22R resistor in series on the signal lines to enhance the ESD protection.
5. Highly recommend reserved 22pF capacitor pulling down to the ground on the UIM_DATA line preventing the radio frequency interference.

3.14 ADC

SIM8970x series module offers two 16-Bit resolution ADC providing by the power management IC. The feature is showing in Table 22.

Table 22: ADC Interface Feature

Parameter	Description	Minimum	Typical	Maximum	Unit
Input voltage range	Programmable	0	-	1.875	V

Resolution		-	16	-	bits
Analog input bandwidth		-	500	-	kHz
Sample rate		-	4.8	-	MHz
ADC resolution (LSB)		-	64.879	-	uV
1/1 channel end-to-end accuracy	Calibrated data result	-11	6	11	mV
1/1 channel end-to-end accuracy with internal pull-up	Calibrated data result	-12.5	7	12.5	mV
1/3 channel end-to-end accuracy	Calibrated data result	-20	10	20	mV
100 K pull-up	Trimmed value	99.5	100	100.5	kΩ
400 K pull-up	Trimmed value	398	100	402	kΩ
30 K pull-up	Trimmed value	29.7	30	30.3	kΩ
1/1 channel AMUX input resistance		10	-	-	MΩ
1/3 channel AMUX input resistance		1	-	-	MΩ

NOTE

Highly recommend connecting the ADC with a resistance voltage division circuit preventing the module from burning due to the high power supply voltage ADC detection.

3.15 Sensor Interface

SIM8970x series module communicates with sensors via I2C or I3C. It supports various sensors, including the hall sensor, the acceleration sensor, the geomagnetism sensor, the gyroscope sensor, the temperature sensor, the light sensor, and the pressure sensor.

The sensors interface's pins in the module are showing in Table 23.

Table 23: Sensor Interface Feature

PIN Name	PIN Num	I/O	Description	Notes
SENSOR_I2C_CLK	38	DO	External Sensor I2C Clock	Need an external 2.2KR pull up resistor
SENSOR_I2C_SDA	39	DI/DO	External Sensor I2C Data	
SNSR_I3C_SDA	72	DI/DO	Sensor I3C Clock	Default for external

SNSR_I3C_SCL	73	DO	Sensor I3C Data	sensors
GPIO_94	53	DI	Hall Interruption	
ACCEL_INT	56	DI	Gyroscope Interruption	
ALSP_INT	57	DI	Light Sensor Interruption	
ACCL_GYRO_DRDY_INT	275	DI	Acceleration Interruption	
GPIO_82	58	DI	Geomagnetism Interruption	
VREG_L9A_1P8	10,12	PO	Sensor I2C Pull Up VDD or VDDIO Power Supply	
VREG_L21A_2P704	5,6	PO	AVDD3.0V Power Supply	

3.16 Motor Interface

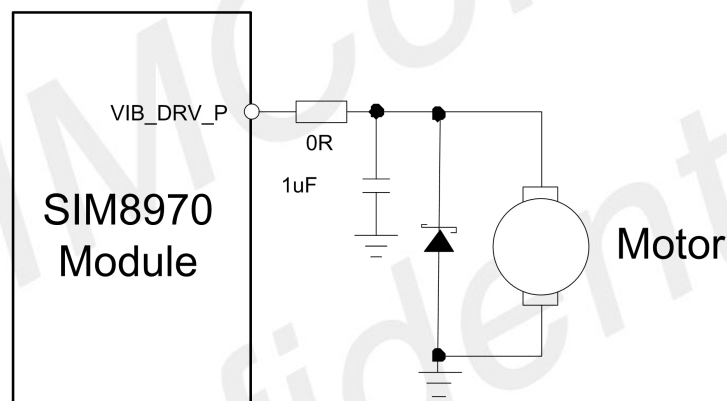

Figure 31: Motor Interface Reference Design

3.17 LED Interface

SIM8970x series module supports RGB tri-color indicator. Selecting a LED chip with the common cathode is needed. The maximum current on each channel is 12mA, and it supports PWM debugging.

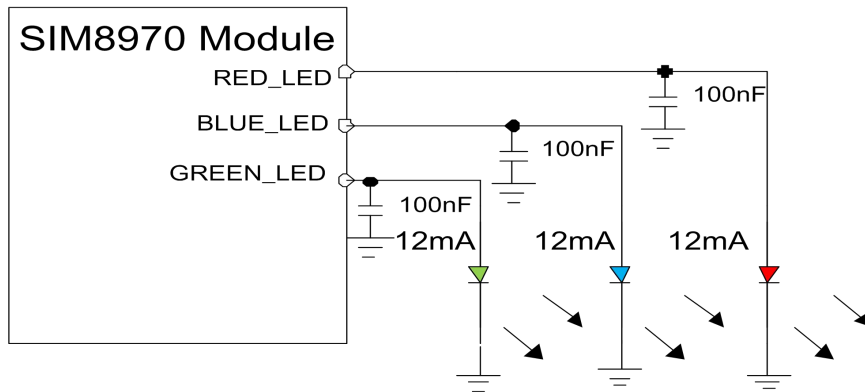

Figure 32: RGB Interface Reference Design

3.18 Flash LED Interface

SIM8970x series module offers two channels of efficient FLASH_LED interface. The maximum current on each channel is 1.5A.

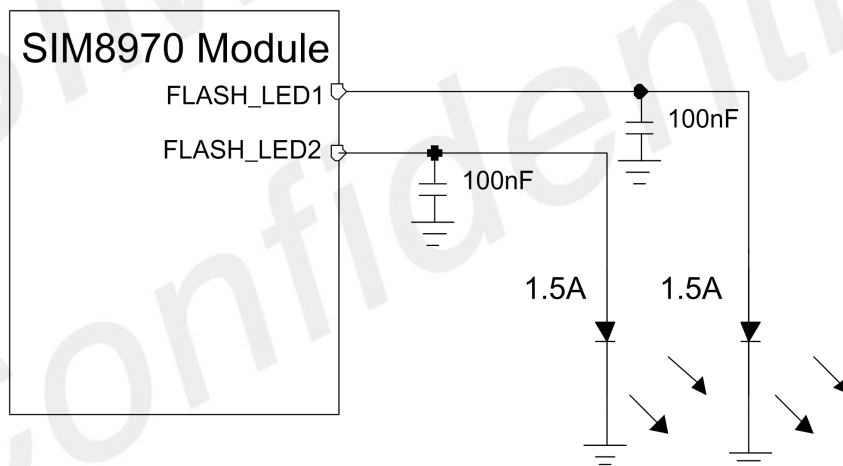

Figure 33: Flash LED Interface Reference Design

3.19 Forced Emergency Download Interface

SIM8970x series module offers a FORCED_USB_BOOT Pin, which is an emergency download interface. Pulling up the FORCED_USB_BOOT to the VREG_L9A_1P8 before powering on enables the module to run into the emergency download mode, which is also applying for the treatment when the product starts abnormally. Highly recommend reserved the testing points for software upgrading and debugging.

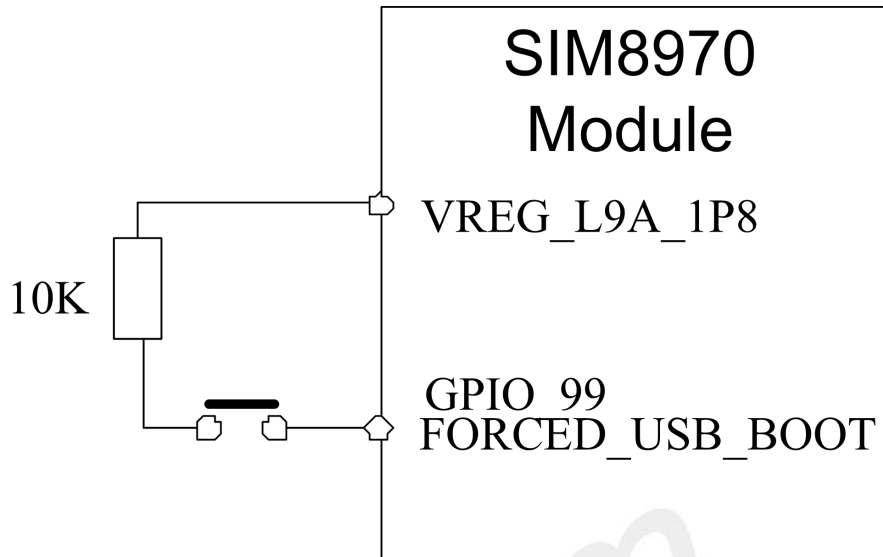

Figure 34: Emergency Download Interface Reference Design

SIMCom
Confidential

4 WIFI & BT

SIM8970x series module offers a common antenna interface combining the WIFI and the BT function. The customers could connect the external WIFI and BT two in one antenna via this interface. In the TDD mode, the WIFI and the BT coexist.

4.1 WIFI Outline

SIM8970x series module supports the 2.4GHz and the 5GHz dual bands WLAN wireless communication. It supports multiple modes, including the 802.11a, the 802.11b, the 802.11g, the 802.11n, and the 802.11ac. The highest rate is 433Mbps. The characteristics are as follows.

- Support the 2.4GHz and the 5GHz dual frequency bands, with the frequencies of 2402MHz~2482MHz and 5180MHz~5825MHz respectively.
- Support the Wake-on-WLAN.
- Support the WAPI SMS4 hardware encryption.
- Support the AP mode and the STATION mode.
- Support the WIFI Direct.
- Support the 2.4G MCS 0~7 for HT20 and VHT20.
- Support the 2.4G MCS 0~8 for HT40 and HT80.
- Support the 5G MCS 0~7 for HT20, HT40 and HT80.
- Support the 5G MCS 0~8 for VHT20.
- Support the 5G MCS 0~9 for VHT40 and VHT80.

4.1.1 WIFI Feature

Table 24: WIFI Emitter Feature

	Standard	Speed	Bandwidth	Output Power ^[1]
2.4GHz	802.11b	CCK 1Mbps	--	17dBm±2dB
	802.11b	CCK 11Mbps	--	17dBm±2dB
	802.11g	6Mbps	20M	16dBm±2dB
	802.11g	54Mbps	20M	14dBm±2dB
	802.11n HT20	MCS0	20M	16dBm±2dB

	802.11n HT20	MCS7	20M	14dBm±2dB
	802.11n HT40	MCS0	40M	15dBm±2dB
	802.11n HT40	MCS7	40M	14dBm±2dB
	802.11ac VHT20	MCS0	20M	15dBm±2dB
	802.11ac VHT20	MCS8	20M	13dBm±2dB
	802.11ac VHT40	MCS0	40M	15dBm±2dB
	802.11ac VHT40	MCS9	40M	10dBm±2dB
5GHz	802.11a	OFDM 6Mbps	20M	16dBm±2dB
	802.11a	OFDM 54Mbps	20M	13dBm±2dB
	802.11n HT20	MCS0	20M	16dBm±2dB
	802.11n HT20	MCS7	20M	12dBm±2dB
	802.11n HT40	MCS0	40M	13dBm±2dB
	802.11n HT40	MCS7	40M	11dBm±2dB
	802.11n HT80	MCS0	80M	13dBm±2dB
	802.11n HT80	MCS7	80M	11dBm±2dB
	802.11ac VHT20	MCS0	20M	16dBm±2dB
	802.11ac VHT20	MCS8	20M	11dBm±2dB
	802.11ac VHT40	MCS0	40M	13dBm±2dB
	802.11ac VHT40	MCS9	40M	9dBm±2dB
	802.11ac VHT80	MCS0	80M	12dBm±2dB
	802.11ac VHT80	MCS9	80M	9dBm±2dB

NOTE

The output power value is testing based on the standards of Mask and EVM.

Table 25: WIFI Receiver Feature

	Standard	Speed	Bandwidth	Receiving Sensitivity
2.4GHz	802.11b	CCK 1Mbps	--	< -89dBm
	802.11b	CCK 11Mbps	--	< -79dBm
	802.11g	6Mbps	20M	< -85dBm
	802.11g	54Mbps	20M	< -68dBm
	802.11n HT20	MCS0	20M	< -85dBm
	802.11n HT20	MCS7	20M	< -67dBm
	802.11n HT40	MCS0	40M	< -82dBm
	802.11n HT40	MCS7	40M	< -64dBm
	802.11ac VHT20	MCS0	20M	< -85dBm
	802.11ac VHT20	MCS8	20M	< -62dBm
	802.11ac VHT40	MCS0	40M	< -82dBm
	802.11ac VHT40	MCS9	40M	< -57dBm

5GHz	802.11a	OFDM 6Mbps	20M	< -85dBm
	802.11a	OFDM 54Mbps	20M	< -68dBm
	802.11n HT20	MCS0	20M	< -85dBm
	802.11n HT20	MCS7	20M	< -67dBm
	802.11n HT40	MCS0	40M	< -82dBm
	802.11n HT40	MCS7	40M	< -64dBm
	802.11n HT80	MCS0	80M	< -79dBm
	802.11n HT80	MCS7	80M	< -54dBm
	802.11ac VHT20	MCS0	20M	< -85dBm
	802.11ac VHT20	MCS8	20M	< -62dBm
	802.11ac VHT40	MCS0	40M	< -82dBm
	802.11ac VHT40	MCS9	40M	< -57dBm
	802.11ac VHT80	MCS0	80M	< -79dBm
	802.11ac VHT80	MCS9	80M	< -54dBm

4.2 BT Outline

SIM8970x series module supports the BT5.0. It supports multiple modes, including the GFSK, the 8-DPSK, and the $\pi/4$ -DQPSK. The performance indexes are showing as follows.

Table 26: BT RF Feature

Emission Feature			
Mode	DH5	2DH5	3DH5
Emission Power	11dBm \pm 2dB	10dBm \pm 2dB	10dBm \pm 2dB
Receiving Feature			
Mode	DH5	2DH5	3DH5
Receiving Sensitivity	< -90dBm	< -90dBm	< -80dBm

5 GNSS

SIM8970x series module supports multiple positioning systems, including the GPS, the GLONSS, and the BeiDou. LNA is a built-in component in the module to effectively enhance the receiving sensitivity of GNSS.

5.1 GNSS Outline

Table 27: GNSS Feature

Parameter	Status	Typical	Unit
CN0	CN Value	40@-130dBm	dB/Hz
Static Drift	CEP-50	5	m
Sensitivity	Tracking	≤-160	dBm
	Recapturing	≤-158	dBm
	Cold Booting	≤-148	dBm
TTFF	Cold Booting	<35	s
	Warm Booting	<15	s
	Hot Booting	<5	s

5.2 GNSS RF & Antenna Design Guideline

The GNSS signal is a weak signal. If the antennas and the routings are not designed properly, it is easy to interfere with the GNSS signal, resulting in the decline of the GNSS receiving sensitivity, and even the GNSS positioning time. To avoid the negative effects, the following principles shall be observed in GNSS RF Design.

- The isolation between the GNSS antenna and other antennas shall be at least 15dB.
- The GNSS RF signal lines and RF related components must be away from the high-speed signals, the power switch signals, and other clock signals.
- The GNSS antenna must be away from the LCD screen, the camera, and other peripherals.
- The GNSS antenna shall be placed close to the top of the equipment as far as possible.
- Refer to chapter 6.4 for the GNSS antenna reference design.

6 Antenna Interface

SIM8970x series module has four antenna interfaces, including the MAIN antenna, the DRX antenna, the GNSS antenna, and the WIFI/BT antenna. To ensure the well RF performance of the products, the RF lines wiring through the antenna pin to the antenna interfaces must meet the following requirements.

- Ensure the RF lines are wiring with the 50Ω impedance.
- The RF lines must have a complete stereo ground plane.
- The RF lines must away from the other interference sources, including the high-speed signals, the clock signals, the sound sensing devices, and the motor, etc.
- The RF lines shall be as short as possible to avoid loss and interference.

6.1 MAIN Antenna & DRX Antenna

The MAIN antenna interface and the DRX antenna interface feature are showing as follows.

Table 28: MAIN Antenna & DRX Antenna Feature

PIN Name	PIN Num	I/O	Description	Feature
ANT_TRX	60	AI/AO	2G/3G/4G Main Antenna Interface	50Ω Impedance
ANT_DRX	41	AI	4G DRX Antenna Interface	50Ω Impedance

6.1.1 Operating Frequency Band

SIM8970x series module's operating frequency bands are showing as follows.

Table 29: Operating Frequency Band

Frequency Band	Receiver	Emitter	Channel
GSM850	869-894MHz	824-849MHz	128-251
EGSM900	925-960MHz	880-915MHz	0-124, 975-1023
DCS1800	1805-1880MHz	1710-1785MHz	512-885
PCS1900	1930-1990MHz	1850-1910MHz	512-810
WCDMA B1	2110-2170 MHz	1920-1980 MHz	TX: 9612-9888 ; RX: 10562-10838

WCDMA B2	1930-1990MHz	1850-1910MHz	TX: 9262-9538 ; RX: 9662-9938
WCDMA B4	2110-2155MHz	1710-1755MHz	TX: 1312-1862 ; RX: 1537-2087
WCDMA B5	869-894MHz	824-849MHz	TX: 4132-4233 ; RX: 4357-4458
WCDMA B8	925-960MHz	880-915 MHz	TX: 2712-2863 ; RX: 2937-3088
LTE B1	2110-2170 MHz	1920-1980 MHz	TX: 18000-18599 RX: 0-599
LTE B2	1930-1990MHz	1850-1910MHz	TX: 18600-19199 RX: 600-1199
LTE B3	1805-1880 MHz	1710-1785 MHz	TX: 19200-19949 RX: 1200-1949
LTE B4	2110-2155MHz	1710-1755MHz	TX: 19950-20399 RX: 1950-2399
LTE B5	869-894 MHz	824-849MHz	TX: 20400-20649 RX: 2400-2649
LTE B7	2620-2690MHz	2500-2570MHz	TX: 20750-21449 RX: 2750-3449
LTE B8	925-960 MHz	880-915 MHz	TX: 21450-21799 RX: 3450-3799
LTE B12	729-746MHz	699-716MHz	TX: 23010-23179 RX: 5010-5179
LTE B13	746-756MHz	777-787MHz	TX: 23180-23279 RX: 5180-5279
LTE B17	734-746MHz	704-716MHz	TX: 23730-23849 RX: 5730-5849
LTE B20	791-821MHz	832-862MHz	TX: 24150-24449 RX: 6150-6449
LTE B25	1850-1915MHz	1930-1995MHz	TX: 26040-26689 RX: 8040-8689
LTE B26	859-894MHz	814-849MHz	TX: 26690-27039 RX: 8690-9039
LTE B28	758-803MHz	703-748MHz	TX: 27210-27259 RX: 9210-9659
LTE B34	2010-2025 MHz	2010-2025 MHz	36200-36349
LTE B38	2570-2620 MHz	2570-2620 MHz	37750-38249
LTE B39	1880-1920 MHz	1880-1920 MHz	38250-38649
LTE B40	2300-2400 MHz	2300-2400 MHz	38650-39649
LTE B41	2555-2655 MHz	2555-2655MHz	40240-41240

NOTE

The bandwidth of LTE TDD B41 band of SIM8970x series module is 100MHz (2555~2655 MHz), and the channel is 40240~41240.

6.1.2 RF Reference Design

SIM8970x series module's MAIN antenna reference design is showing as follows.

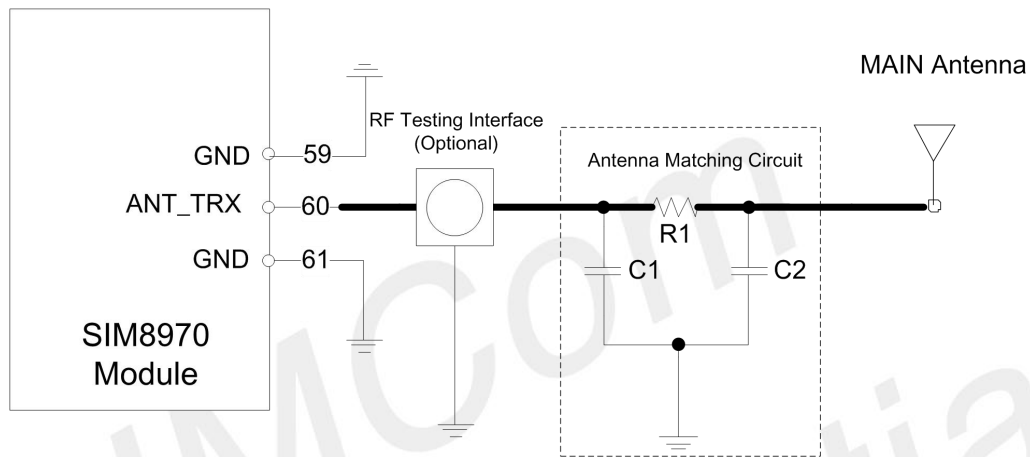

Figure 35: MAIN Antenna Reference Design

In Figure 35, R1, C1, and C2 are the antenna matching components. All these three components are adjustable to match the efficient and effective communication quality based on the interface debugging result. Selecting R1 with 0R resistor by default, and reserved C1 and C2 with disconnection by default. Highly recommend reserved an RF testing interface to modify accurately and conveniently. Considering the low cost, recommend ensure 50Ω impedance for the RF lines and cancel the RF testing interface.

SIM8970x series module's DRX antenna reference design is showing as follows.

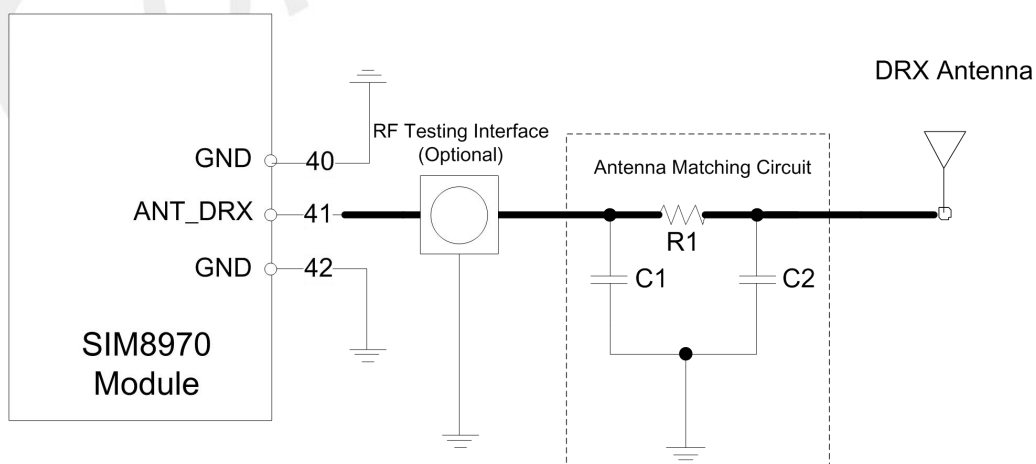

Figure 36: DRX Antenna Reference Design

In Figure 36, R1, C1 and C2 are the antenna matching components. All these three components are

adjustable to match the efficient and effective communication quality based on the interface debugging result. Selecting R1 with 0R resistor by default, and reserved C1 and C2 with disconnection by default. Highly recommend reserved an RF testing interface to modify accurately and conveniently. Considering the low cost, recommend ensure 50Ω impedance for the RF lines and cancel the RF testing interface.

6.2 WIFI/BT Antenna Interface

SIM8970x series module's WIFI/BT antenna interface feature is showing as follows.

Table 30: WIFI/BT Antenna Feature

PIN Name	PIN Num	I/O	Description	Feature
ANT_WIFI/BT	2	AI/AO	WIFI/BT Antenna Interface	50Ω Impedance

SIM8970x series module's WIFI/BT operating frequency bands are showing as follows.

Table 31: WIFI/BT Operating Frequency Band

Type	Frequency Band	Unit
802.11a/b/g/n/ac	2402~2482	MHz
	5180~5825	
BT 5.0	2402~2482	MHz

SIM8970x series module's WIFI/BT antenna reference design is showing as follows.

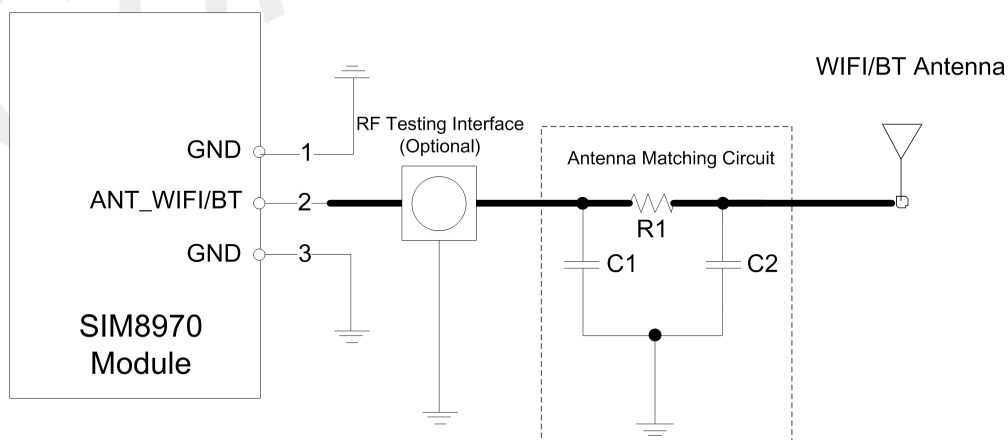

Figure 37: WIFI/BT Antenna Reference Design

In Figure 37, R1, C1 and C2 are the antenna matching components. All these three components are adjustable to match the efficient and effective communication quality based on the interface debugging

result. Selecting R1 with 0R resistor by default, and reserved C1 and C2 with disconnection by default. Highly recommend reserved an RF testing interface to modify accurately and conveniently. Considering the low cost, recommend ensure 50Ω impedance for the RF lines and cancel the RF testing interface.

6.3 GNSS Antenna Interface

SIM8970x series module's GNSS antenna interface feature is showing as follows.

Table 32: GNSS Antenna Feature

PIN Name	PIN Num	I/O	Description	Feature
ANT_GNSS	49	AI	GNSS Antenna Interface	50Ω Impedance
GNSS_LNA_CTRL	185	DO	External GNSS LNA Control Signal	Suspend if no connection

SIM8970x series module's GNSS operating frequency bands are showing as follows.

Table 33: GNSS Operating Frequency Band

Type	Frequency Band	Unit
GPS	1575.42±1.023	MHz
GLONASS	1597.5~1605.8	MHz
BeiDou	1559.05 – 1563.14	MHz

6.3.1 GNSS Passive Antenna Reference Design

SIM8970x series module's GNSS passive antenna reference design is showing as follows.

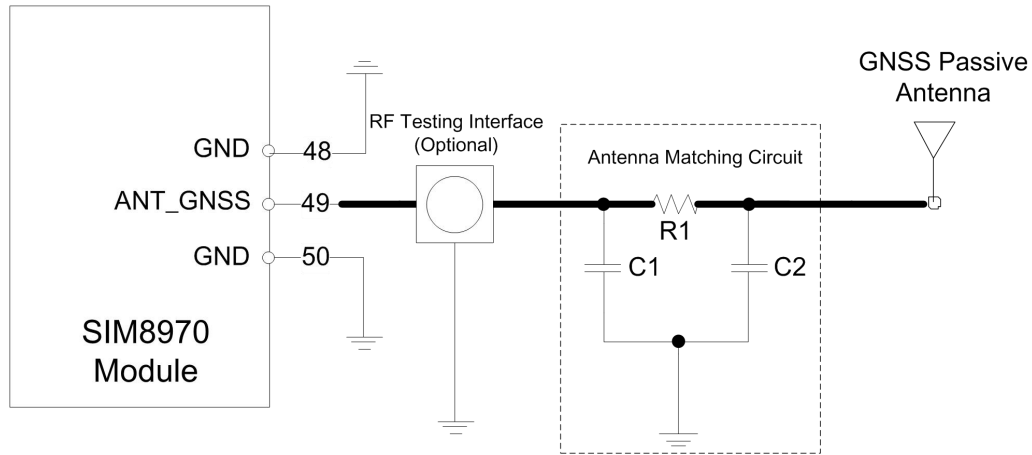

Figure 38: GNSS Passive Antenna Reference Design

In Figure 38, R1, C1 and C2 are the antenna matching components. All these three components are adjustable to match the efficient and effective communication quality based on the interface debugging result. Selecting R1 with 0R resistor by default, and reserved C1 and C2 with disconnection by default. Highly recommend reserved an RF testing interface to modify accurately and conveniently. Considering the low cost, recommend ensure 50Ω impedance for the RF lines and cancel the RF testing interface.

6.3.2 GNSS Active Antenna Reference Design

SIM8970x series module's GNSS active antenna reference design is showing as follows.

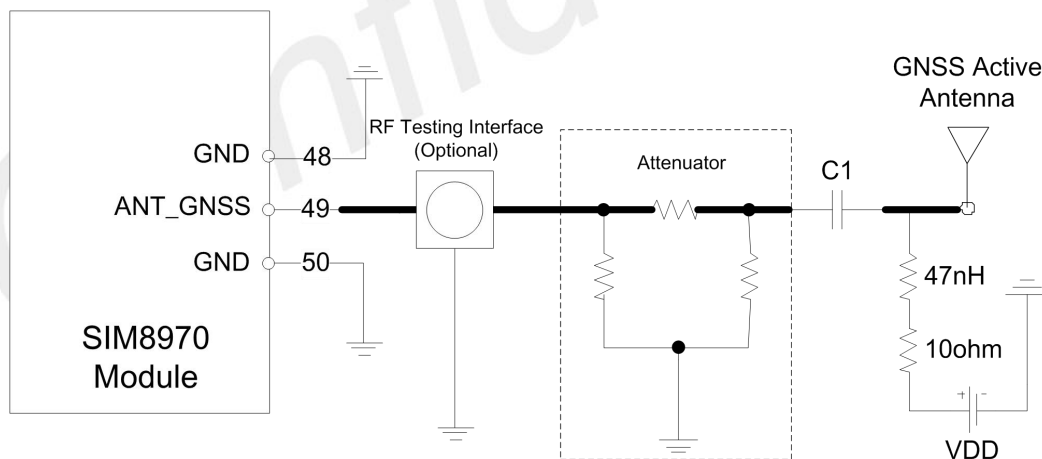

Figure 39: GNSS Active Antenna Reference Design

In Figure 39, highly recommend reserved the attenuator, and the attenuation value is determined by the gain of the external active antenna. Generally speaking, the attenuation value and antenna gain of the attenuator meet the following formula.

$$\text{Antenna Gain} = \text{Attenuation value} + \text{Cable Losses}$$

VDD is using to for the active antenna’s power supply. The voltage value is determined by the antenna’s feature. C1 is using to isolate straight, and the default value is 33pF. Highly recommend reserved an RF testing interface to modify accurately and conveniently. Considering the low cost, recommend ensure 50Ω impedance for the RF lines and cancel the RF testing interface.

6.4 RF Signals PCB Wiring Guideline

Highly recommend the characteristic impedance of all RF signal lines shall be controlled at 50Ω when the customers route their PCB. Generally, the impedance of RF signal lines is determined by the dielectric constant (ER), the wiring width (W), the ground clearance (S), the height of the reference ground plane (H), and other factors.

RF routing characteristic impedance control usually adopts the microstrip-slot line and the coplanar waveguide-slot line. The reference designs of 50Ω impedance are showing as follows.

- **Microstrip-slot Line Structure**

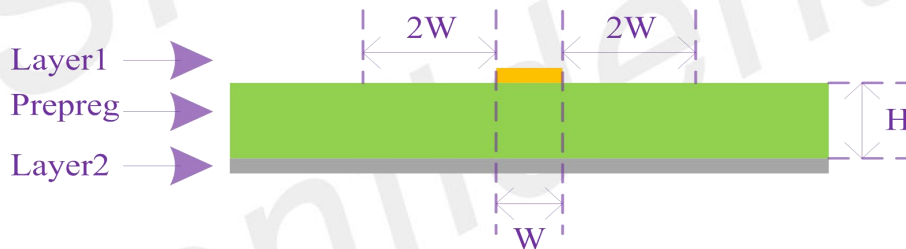

Figure 40: Two Layers PCB Microstrip-slot Line Structure

Table 34: Two Layers PCB Microstrip-slot Line Structure Impedance Control Feature

Thickness	Er	Signal Thickness	Signal Layer	Reference Layer	Impedance	Width
1mm	4.2	0.035mm	Layer1	Layer2	50 ohm	1.7mm (67 mil)
1.6mm	4.2	0.035mm	Layer1	Layer2	50 ohm	3mm (118 mil)

- **Coplanar Waveguide-slot Line**

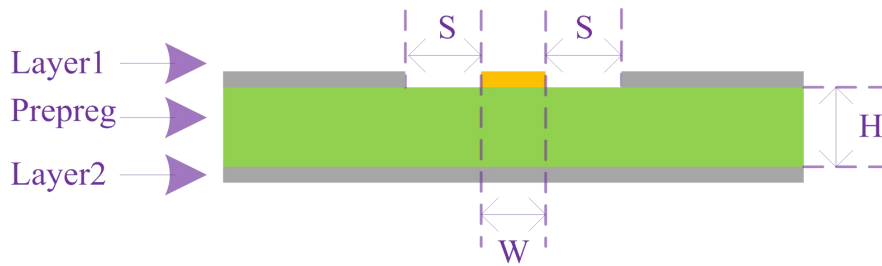

Figure 41: Two Layers PCB Coplanar Waveguide-slot Line Structure

Table 35: Two Layers PCB Coplanar Waveguide-slot Line Structure Impedance Control Feature

Thickness	Er	Signal Thickness	Signal	Reference	Impedance	S	W
1mm	4.2	0.035mm	Layer1	Layer2	50 ohm	0.65mm(25.6 mil)	0.2mm (7.8 mil)
1.6mm	4.2	0.035mm	Layer1	Layer2	50 ohm	0.65mm(25.6 mil)	0.15mm (5.9 mil)

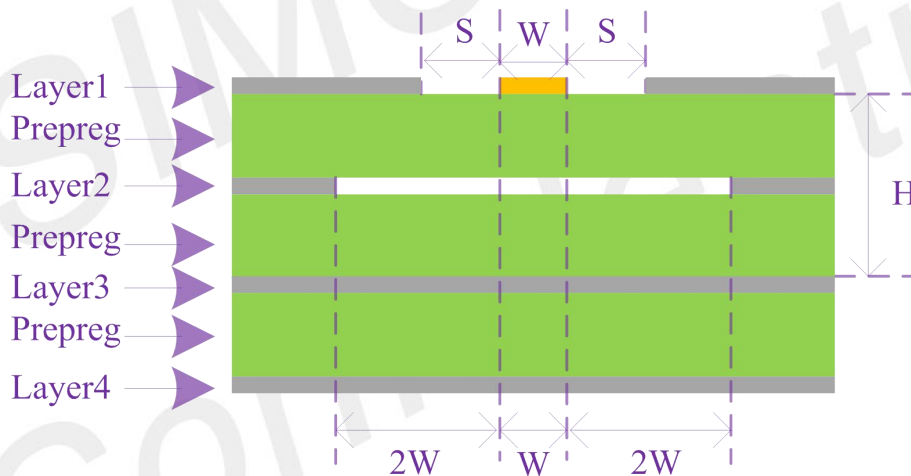

Figure 42: Four Layers PCB Coplanar Waveguide-slot Line Structure (Reference Layer Three)

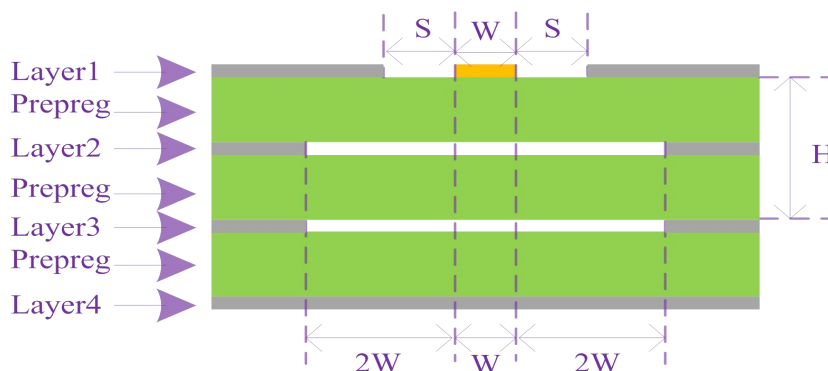

Figure 43: Four Layers PCB Coplanar Waveguide-slot Line Structure (Reference Layer Four)

To ensure the well RF performance of the products, the RF lines wiring through the antenna pin to the antenna interfaces must meet the following requirements.

- Ensure the RF lines are wiring with the 50Ω impedance.
- The RF lines must have a complete stereo ground plane.
- Add more ground holes around the RF signal lines and the reference ground to enhance the RF performance.
- The RF lines must away from the other interference sources, including the high-speed signals, the clock signals, the sound sensing devices, and the motor, etc.
- The RF lines shall be as short as possible to avoid loss and interference.
- The GND pin adjacent to the RF interface pin of the module is not subject to thermal pad treatment and is in full contact with the ground.
- Avoid wiring crossing the whole PCB. Avoid the right-angle routing. Highly recommend wiring with a circular arc or a 135-degree routing.
- Be aware of the distance between the components and the lower PCB ground, especially for the RF connecting device package.
- Digging out the GND copper foil on the surface of the PCB below the connector if necessary.
- The distance between the ground hole and the signal line shall be at least 2 times the line width(2*W).

6.5 Antenna Installation

6.5.1 GNSS Passive Antenna Reference Design

SIM8970x series module's antenna interface installation requirements are showing as follows.

Table 36: Antenna Installation Requirements

Antenna	Parameters' Requirements
GSM/WCDMA/LTE	Standing wave ratio: ≤ 2 Gain (dBi): >1 Maximum Input Power (W): 50 Input Impedance (Ω): 50 Polarization Type: Vertical Insertion Loss: $< 1\text{dB}$ (GSM850/EGSM900, WCDMA B5/B8, LTE B5/B8/B12/B17/ B20) Insertion Loss: $< 1.5\text{dB}$ (DCS1800/PCS1900, WCDMA B1/B2/B3/B4, LTE

	<p>B1/B2/B3/B4/B39) Insertion Loss: < 2dB (B7/B38/B40/B41)</p>
Wi-Fi/BT	<p>Standing wave ratio: ≤ 2 Gain (dBi): > 1 Maximum Input Power (W): 50 Input Impedance (Ω): 50 Polarization Type: Vertical Insertion Loss: < 1dB</p>
GNSS	<p>Frequency Range: 1559 - 1607MHz Polarization Type: Right-Handed Circular or Linear Polarization Standing wave ratio: < 2 (Typical) Passive Antenna Gain: > 0dBi Active Antenna Noise Coefficient: < 1.5dB (Typical) Active Antenna Gain: > -2dBi Active Antenna Integrated LNA Gain: <17dB (Typical) Active Antenna Total Gain: <17dBi (Typical)</p>

6.5.2 RF Connector

Highly recommend pick the Hirose U.FL-R-SMT's RF connector.

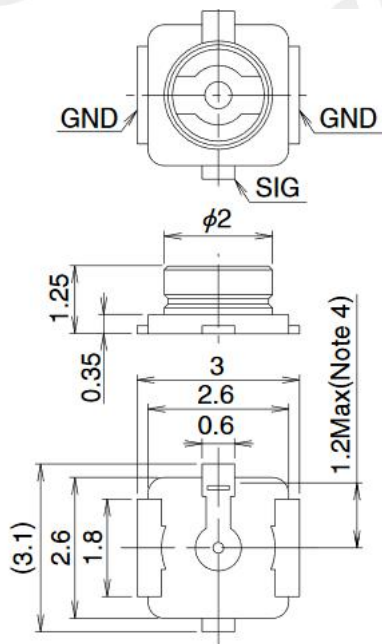

U.FL-R-SMT-1

Figure 44: Hirose U.FL-R-SMT Connector's Size and Package

Recommended PCB Mounting Pattern

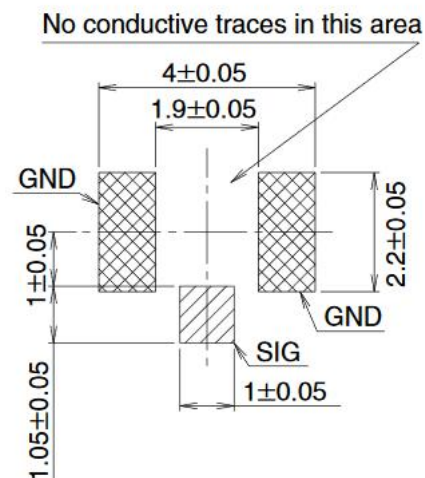

7 PCB Wiring

This chapter mainly introduces the requirements in PCB layout wiring. The purpose is to minimize the interference issue, to optimize the product performance, and to shorten the Research and Development (R&D) cycle.

7.1 Stack Selection

Highly recommend at least a four-layer through holes PCB layout design to facilitate impedance control and signal line shielding.

7.2 PCB Routing Guidelines

Highly recommend considering the following aspects in PCB layout design.

7.2.1 Antenna

SIM8970x series modules has four antenna interfaces in total, including the ANT_TRX, the ANT_DRX, the ANT_GNSS, and the ANT_WIFI/BT. The requirements for the RF components are showing as follows.

- Ensure the RF lines are wiring with the 50Ω impedance.
- The RF lines must have a complete stereo ground plane.
- Add more ground holes around the RF signal lines and the reference ground to enhance the RF performance.
- The RF lines must away from the other interference sources, including the high-speed signals, the clock signals, the sound sensing devices, and the motor, etc.
- The RF lines shall be as short as possible to avoid loss and interference.
- Avoid wiring crossing the whole PCB. Avoid the right-angle routing. Highly recommend wiring with a circular arc or a 135-degree routing.
- Be aware of the distance between the components and the lower PCB ground, especially for the RF connecting device package.

7.2.2 Power Supply & Ground

Highly recommend wiring the VBAT positive electrode as short and thick as possible. Highly recommend wiring through large capacitors and zener diodes before connecting to the power supply pin of the module. Considering the backflow ground of the power supply is necessary when routing. Wiring the VBAT to the ground path as short as possible to ensure the lower impedance.

7.2.3 UIM Card

The requirements for the UIM card are showing as follows.

- Highly recommend the UIM card receptacle interface is away from the RF antennas.
- Highly recommend wiring the UIM card signals away from the RF signal lines, the VBAT, and the high-speed signal lines as far as possible.
- Highly recommend the ground of the UIM card is well connecting to the main ground of the module.
- Notice that well protect the UIM_CLK signal to prevent the interference from other signals.
- Highly recommend wiring the UIM card signals away from the return path of the VBAT because there is a large current passing through the return path on VBAT.

7.2.4 MIPI

The requirements for the MIPI signal are showing as follows.

- Two-phase differential pair routings with 85Ω differential impedance and the error at $\pm 15\Omega$.
- Three-phase differential pair routings with 44Ω single ended and the error at $\pm 15\Omega$.
- Highly recommend a complete stereo ground plane and the full reference ground.
- Highly recommend minimizing the number of vias.
- Highly recommend the total length of wiring is less than 305mm.
- Highly recommend the length difference in the group is less than 0.7mm.
- Highly recommend the length difference between groups is less than 1.4mm.

Table 37: MIPI Lane Wiring Difference

PIN Num	PIN Name	Length (mm)	Difference (mm)
135	MIPI_DSIO_CLK_P	21.97547	-0.05407
136	MIPI_DSIO_CLK_N	22.02954	-0.02353
137	MIPI_DSIO_LANE0_P	22.60134	-0.02353

138	MIPI_DSI0_LANE0_N	22.62487	
139	MIPI_DSI0_LANE1_P	24.74884	0.25135
140	MIPI_DSI0_LANE1_N	24.49749	
141	MIPI_DSI0_LANE2_P	23.92674	-0.00926
142	MIPI_DSI0_LANE2_N	23.936	
143	MIPI_DSI0_LANE3_P	26.10372	-0.08474
144	MIPI_DSI0_LANE3_N	26.18846	
124	MIPI_DSI1_CLK_P	38.09878	-0.19021
125	MIPI_DSI1_CLK_N	38.28899	
113	MIPI_CSI0_CLK_P	43.49691	0.03754
112	MIPI_CSI0_CLK_N	43.45937	
111	MIPI_CSI0_LANE0_P	43.19501	-0.02627
110	MIPI_CSI0_LANE0_N	43.22128	
109	MIPI_CSI0_LANE1_P	41.43217	-0.07165
108	MIPI_CSI0_LANE1_N	41.50382	
107	MIPI_CSI0_LANE2_P	40.80432	0.23645
106	MIPI_CSI0_LANE2_N	40.56787	
105	MIPI_CSI0_LANE3_P	41.49281	0.02449
104	MIPI_CSI0_LANE3_N	41.46832	
238	MIPI_CSI1_CLK_P	15.48576	0.23666
239	MIPI_CSI1_CLK_N	15.2491	
242	MIPI_CSI1_LANE0_P	10.15489	0.04806
243	MIPI_CSI1_LANE0_N	10.10683	
240	MIPI_CSI1_LANE1_P	12.392	-0.23669
241	MIPI_CSI1_LANE1_N	12.62869	
244	MIPI_CSI1_LANE2_P	10.98103	0.03586
245	MIPI_CSI1_LANE2_N	10.94517	
246	MIPI_CSI1_LANE3_P	16.96772	-0.0759
247	MIPI_CSI1_LANE3_N	17.04362	
102	MIPI_CSI2_CLK_P	37.03927	-0.02341
101	MIPI_CSI2_CLK_N	37.06268	
100	MIPI_CSI2_LANE0_P	37.67666	0.21704
99	MIPI_CSI2_LANE0_N	37.45962	
98	MIPI_CSI2_LANE1_P	35.15474	0.00189
97	MIPI_CSI2_LANE1_N	35.15285	
280	MIPI_CSI2_LANE2_P	38.18135	-0.52305
279	MIPI_CSI2_LANE2_N	38.7044	
278	MIPI_CSI2_LANE3_P	36.65766	0.02855
277	MIPI_CSI2_LANE3_N	36.62911	

7.2.5 USB

The requirements for the USB signal are showing as follows.

- Highly recommend place the common mode inductance close to the USB connector.
- Differential pair routings with 90Ω differential impedance and the error at ±10%.
- Highly recommend the length difference of HS differential pair is less than 2.0mm.
- Highly recommend the length difference of SS differential pair is less than 0.7mm.
- If SS lanes need to be compatible with DP function, the spacing between the groups of the USB0_SS_RX0_M/P, the USB0_SS_TX0_M/P, the USB0_DP_AUX_M/P, the USB0_SS_RX1_M/P, and the USB0_SS_TX1_M/P is less than 9mm.
- If no DP function, it is unnecessary to consider the equal length of the USB0_SS_TX and the USB0_SS_RX.
- Highly recommend wiring the VBUS as wide as possible if the USB integrates the charging function.
- Highly recommend placing the testing points on the routing path to minimize the branch length.
- Place the data line of the USB signal away from sensitive circuits or signals because they are high-frequency signals. The sensitive signals include the RF signals, the audio signals, and the 38.4MHZ XO signals.
- Highly recommend reserved the RX and the TX at least 3 times the linewidth, and other signals 4 times the linewidth.

Table 38: SIM8970CE USB Wiring Length

PIN Num	PIN Name	Length (mm)	Difference (mm)
146	USB_DP	49.62281	-0.16363
147	USB_DM	49.78644	-0.16363
193	USB0_SS_RX0_P	18.93389	0.03285
194	USB0_SS_RX0_M	18.90104	0.03285
196	USB0_SS_TX0_P	22.4484	-0.03913
197	USB0_SS_TX0_M	22.48753	-0.03913
324	USB0_SS_RX1_P	13.38855	-0.08575
323	USB0_SS_RX1_M	13.4743	-0.08575
325	USB0_SS_TX1_P	17.4537	-0.04574
326	USB0_SS_TX1_M	17.49944	-0.04574
321	USB0_DP_AUX_P	9.32287	0.35698
320	USB0_DP_AUX_M	8.96589	0.35698

Notice that the SIM8970CE module and the SIM8970EU module has different USB wiring routes.

Table 39: SIM8970EU USB Wiring Length

PIN Num	PIN Name	Length (mm)	Difference (mm)
146	USB_DP	49.62281	-0.16363

147	USB_DM	49.78644	
193	USB0_SS_RX0_P	19.64355	0.41783
194	USB0_SS_RX0_M	19.22572	
196	USB0_SS_TX0_P	22.37591	-0.11162
197	USB0_SS_TX0_M	22.48753	
324	USB0_SS_RX1_P	13.86048	0.29023
323	USB0_SS_RX1_M	13.57025	
325	USB0_SS_TX1_P	17.62767	-0.05816
326	USB0_SS_TX1_M	17.68583	
321	USB0_DP_AUX_P	9.20959	0.2437
320	USB0_DP_AUX_M	8.96589	

7.2.6 SD Card

The requirements for the SD card signal are showing as follows.

- Highly recommend a complete stereo ground plane and the full reference ground.
- Differential pair routings with 50Ω differential impedance and the error at ±10%.
- Highly recommend the length difference between the CLK and the DATA/CMD is less than 1mm.
- Highly recommend the line spacing at least 2 times the linewidth.
- Highly recommend the total capacitance on the 50MHz signal line shall be less than 22pF, and the wiring length is less than 40mm.
- Highly recommend the total capacitance on the 208MHz signal line shall be less than 5pF, and the wiring length is less than 20mm.

Table 40: SD Card Wiring Length

PIN Num	PIN Name	Length (mm)
150	SDCARD_DET_N	34.1315
151	SDC2_DAT3	59.08302
152	SDC2_DAT2	57.90951
153	SDC2_DAT1	57.74459
154	SDC2_DAT0	56.87189
155	SDC2_CMD	55.6423
156	SDC2_CLK	53.32648

7.2.7 Audio

The requirements for the audio signal are showing as follows.

- Highly recommend wiring the audio signal lines away from the antennas, the RF signal lines, and other high-speed signal lines.
- Highly recommend all the audio signal lines are wiring with a complete stereo ground plane and the full reference ground, and away from the return VBAT.
- Highly recommend wiring the MIC1_P/N, the EAR_P/ N, and the SPK_P/N as differential pairs.
- Highly recommend isolating the HPH_L and the HPH_R with the HPH_REF in the middle to decrease the crosstalk interference.
- Highly recommend wiring the 25mil line width for the SPKR signal when picking an 8Ω load.
- Highly recommend wiring the 30mil line width for the SPKR signal when picking a 4Ω load.

SIMCom
Confidential

8 Electrical & Reliability

8.1 Absolute Maximum Value

Table 41: Absolute Maximum Value

Parameter	Description	Minimum	Maximum	Unit
VBAT	DC Supply Voltage	-0.3	5	V
VBUS	USB 5V Supply Voltage	-0.3	12	V
VRTC	Backup Battery Supply Voltage	-	3.5	V

8.2 Temperature Range

Table 42: Temperature Range

Parameter	Minimum	Typical	Maximum	Unit
Operating Temperature	-35	25	+75	°C
Storage Temperature	-40		+90	°C

8.3 Operating Voltage

Table 43: Operating Voltage

Parameter	Minimum	Typical	Maximum	Unit
VBAT	3.4	3.8	4.7	V
VBUS	4.35	-	10	V
VRTC	2.1	3.0	3.25	V

8.4 Digital Interface Feature

Table 44: SDC2 Interface Electrical Feature (1.8V)

Parameter	Description	Minimum	Typical	Maximum	Unit
V _{IH}	High Level Input Voltage	1.27	-	2	V
V _{IL}	Low Level Input Voltage	-0.3	-	0.58	V
V _{OH}	High Level Output Voltage	1.4	-	-	V
V _{OL}	Low Level Output Voltage	0	-	0.45	V

Table 45: SDC2 Interface Electrical Feature (2.96V)

Parameter	Description	Minimum	Typical	Maximum	Unit
V _{IH}	High Level Input Voltage	1.85	-	3.25	V
V _{IL}	Low Level Input Voltage	-0.3	-	0.74	V
V _{OH}	High Level Output Voltage	2.21	-	2.96	V
V _{OL}	Low Level Output Voltage	0	-	0.37	V

Table 46: UIM Card Interface Electrical Feature (VREG_UIM = 1.8V or 2.95V)

Parameter	Description	Minimum	Typical	Maximum	Unit
V _{IH}	High Level Input Voltage	0.7* VREG_UIM	-	VREG_UIM+0.3	V
V _{IL}	Low Level Input Voltage	-0.3	-	0.2* VREG_UIM	V
V _{OH}	High Level Output Voltage	0.8*VREG_UIM	-	VREG_UIM	V
V _{OL}	Low Level Output Voltage	0	-	0.4	V

Table 47: GPIO Electrical Feature

Parameter	Description	Minimum	Typical	Maximum	Unit
V _{IH}	High Level Input Voltage	1.17	-	-	V
V _{IL}	Low Level Input Voltage	-	-	0.6	V
V _{OH}	High Level Output Voltage	1.3	-	-	V
V _{OL}	Low Level Output Voltage	-	-	0.45	V

8.5 Current Consumption (VBAT = 3.9V)

Table 48: Current Consumption

Parameter	Condition	Minimum	Typical	Maximum	Unit
Shutdown Leakage Current	Shutdown Leakage Current	-	121	150	uA
Flight Mode	Flight Mode	-	3.1	3.7	
Standby Current	GSM/GPRS				
	BS-PA-MFRMS=2	-	4.10	5	
	BS-PA-MFRMS=5	-	3.87	5	
	BS-PA-MFRMS=9	-	3.78	5	
	WCDMA, 2.56sec,DRX=8	-	3.305	5	
	LTE-FDD, standby 2.56s, DRX=8	-	3.56	5	
	LTETDD, standby 2.56s, DRX=8	-	3.598	5	
Call Current	GSM Talk				mA
	EGSM900 PCL= 5@ 32.2dB Channel=62	-	241	300	
	EGSM1800 PCL= 0@ 29.7dB Channel=698	-	173	250	
	WCDMA Talk				
	WCDMA TX=0dBm	-	235	250	
	WCDMA TX=10dBm	-	175	200	
	VoL LTE				
	FDD 20MHz TX=0 dBm	-	230	270	
TDD 20MHz TX=0 dBm	-	180	220		
Data Transmission Maximum Current	WCDMA Max power				mA
	WCDMA B1 Max power@ 23.7dBm	-	572	600	
	WCDMA B5 Max power@ 23.0dBm	-	542	570	
	WCDMA B8 Max power@ 23.1dBm	-	545	570	
	LTE FDD Max power				
	B1 power@ 23dBm BW=20MHZ Channel= 18300	-	598	700	
	B3 power@ 23dBm BW=20MHZ Channel= 19575	-	637	700	
	B5 power@ 23dBm BW=20MHZ Channel= 20525	-	542	600	
	B7 power@ 23dBm BW=10MHZ Channel= 21100	-	680	800	
	B8 power@ 23dBm BW=10MHZ Channel= 21625	-	579	600	
	B20 power@ 23dBm BW=20MHZ Channel= 24300	-	549	600	
		-	598	600	
		-	270	-	
		-	324	-	
		-	246	-	
	-	305	-		

	B28 power@ 23dBm BW=20MHZ Channel=27435 LTE TDD Max power B34 power@ 23dBm BW=20MHZ Channel= 36275 B38 power@ 23dBm BW=20MHZ Channel= 37800 B39 power@ 23dBm BW=10MHZ Channel= 38300 B40 power@ 23dBm BW=10MHZ Channel= 38700 B41 power@ 23dBm BW=10MHZ Channel= 40740	-	295	-	
Peak Current	RF Burst			3.0	A

8.6 Electrostatic Protection

Notice that the electrostatic protection is very important when producing, assembling and operating modules. The performance parameters of the module test results are as follows:

Table 49: ESD Feature (Temperature: 25°C, Humidity: 45%)

PIN Name	Contact Discharge	Air Discharge
VBAT	±5KV	±10KV
GND	±6KV	±12KV
Antenna Interface	±5KV	±10KV

8.7 RF Transmission Power

Table 50: Conducted Output Power

Frequency Band	Power	Minimum
GSM850	33dBm ±2dB	5dBm ± 5dB
E-GSM900	33dBm ±2dB	5dBm ± 5dB
DCS1800	30dBm ±2dB	0dBm ± 5dB
PCS1900	30dBm ±2dB	0dBm ± 5dB
GSM850(8-PSK)	27dBm ±3dB	5dBm ± 5dB

E-GSM900 (8-PSK)	27dBm ±3dB	5dBm ± 5dB
DCS1800 (8-PSK)	26dBm +3/-4dB	0dBm ±5dB
PCS1900(8-PSK)	26dBm +3/-4dB	0dBm ±5dB
WCDMA B1	24dBm +1/-3dB	<-50dBm
WCDMA B2	24dBm +1/-3dB	<-50dBm
WCDMA B4	24dBm +1/-3dB	<-50dBm
WCDMA B5	24dBm +1/-3dB	<-50dBm
WCDMA B8	24dBm +1/-3dB	<-50dBm
LTE-FDD B1	23dBm +/-2.7dB	<-40dBm
LTE-FDD B2	23dBm +/-2.7dB	<-40dBm
LTE-FDD B3	23dBm +/-2.7dB	<-40dBm
LTE-FDD B4	23dBm +/-2.7dB	<-40dBm
LTE-FDD B5	23dBm +/-2.7dB	<-40dBm
LTE-FDD B7	23dBm +/-2.7dB	<-40dBm
LTE-FDD B8	23dBm +/-2.7dB	<-40dBm
LTE-FDD B12	23dBm +/-2.7dB	<-40dBm
LTE-FDD B13	23dBm +/-2.7dB	<-40dBm
LTE-FDD B17	23dBm +/-2.7dB	<-40dBm
LTE-FDD B20	23dBm +/-2.7dB	<-40dBm
LTE-FDD B25	23dBm +/-2.7dB	<-40dBm
LTE-FDD B26	23dBm +/-2.7dB	<-40dBm
LTE-FDD B28	23dBm +/-2.7dB	<-40dBm
LTE-TDD B34	23dBm +/-2.7dB	<-40dBm
LTE-TDD B38	23dBm +/-2.7dB	<-40dBm
LTE-TDD B39	23dBm +/-2.7dB	<-40dBm
LTE-TDD B40	23dBm +/-2.7dB	<-40dBm
LTE-TDD B41	23dBm +/-2.7dB	<-40dBm

8.8 Conducted Receiving Sensitivity

Table 51: Conducted Receiving Sensitivity

Frequency Band	Receiving Sensitivity (Typical)	Receiving Sensitivity (Maximum)
GSM850	< -108dBm	3GPP standard
EGSM900	< -108dBm	3GPP standard
DCS1800	< -108dBm	3GPP standard
PCS1900	< -108dBm	3GPP standard
WCDMA B1	<-109dBm	3GPP standard
WCDMA B2	<-109dBm	3GPP standard

WCDMA B4	<-109dBm	3GPP standard
WCDMA B5	<-109dBm	3GPP standard
WCDMA B8	<-109dBm	3GPP standard
LTE FDD/TDD	See Table 51	3GPP standard

Table 52: LTE Reference Sensitivity 3GPP Standard (QPSK)

E-UTRA Frequency Band Code	1.4 MHz	3 MHz	5 MHz	10 MHz	15 MHz	20 MHz	Duplex Mode
1	-	-	-100	-97	-95.2	-94	FDD
2	-102.7	-99.7	-98	-95	-93.2	-92	FDD
3	-101.7	-98.7	-97	-94	-92.2	-91	FDD
4	-104.7	-101.7	-100	-97	-95.2	-94	FDD
5	-103.2	-100.2	-98	-95	-	-	FDD
6	-	-	-100	-97	-	-	FDD
7	-	-	-98	-95	-93.2	-92	FDD
8	-102.2	-99.2	-97	-94	-	-	FDD
9	-	-	-99	-96	-94.2	-93	FDD
10	-	-	-100	-97	-95.2	-94	FDD
11	-	-	-100	-97	-	-	FDD
12	-101.7	-98.7	-97	-94	-	-	FDD
13	-	-	-97	-94	-	-	FDD
14	-	-	-97	-94	-	-	FDD
17	-	-	-97	-94	-	-	FDD
18	-	-	-100	-97	-95.2	-	FDD
19	-	-	-100	-97	-95.2	-	FDD
20	-	-	-97	-94	-91.2	-90	FDD
21	-	-	-100	-97	-95.2	-	FDD
22	-	-	-97	-94	-92.2	-91	FDD
23	-104.7	-101.7	-100	-97	-95.2	-94	FDD
24	-	-	-100	-97	-	-	FDD
25	-101.2	-98.2	-96.5	-93.5	-91.7	-90.5	FDD
26	-102.7	-99.7	-97.5	-94.5	-92.7	-	FDD
28	-	-100.2	-98.5	-95.5	-93.7	-91	FDD
33	-	-	-100	-97	-95.2	-94	TDD
34	-	-	-100	-97	-95.2	-	TDD
35	-106.2	-102.2	-100	-97	-95.2	-94	TDD
36	-106.2	-102.2	-100	-97	-95.2	-94	TDD
37	-	-	-100	-97	-95.2	-94	TDD
38	-	-	-100	-97	-95.2	-94	TDD

39	-	-	-100	-97	-95.2	-94	TDD
40	-	-	-100	-97	-95.2	-94	TDD
41	-	-	-99	-96	-94.2	-93	TDD
42	-	-	-99	-96	-94.2	-93	TDD
43	-	-	-99	-96	-94.2	-93	TDD

SIMCom
Confidential

9 Manufacture & Production

9.1 Top- and Bottom-View of the Module

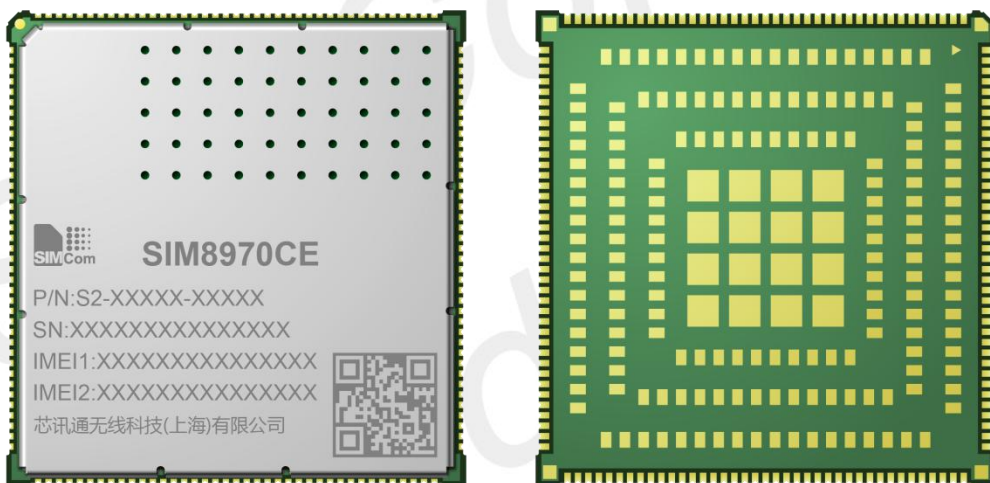

Figure 45: Top- and Bottom-View of the Module

NOTE

This picture is the effect drawing of the module design.

9.5 Recommend Temperature Curve of Reflow Furnace

Setpoints (摄氏)										
温区	1	2	3	4	5	6	7	8	9	10
上温区	100	120	140	160	180	200	215	230	260	220
下温区	100	120	140	160	180	200	215	230	255	220

Conveyor Speed (公分/分): 85.00

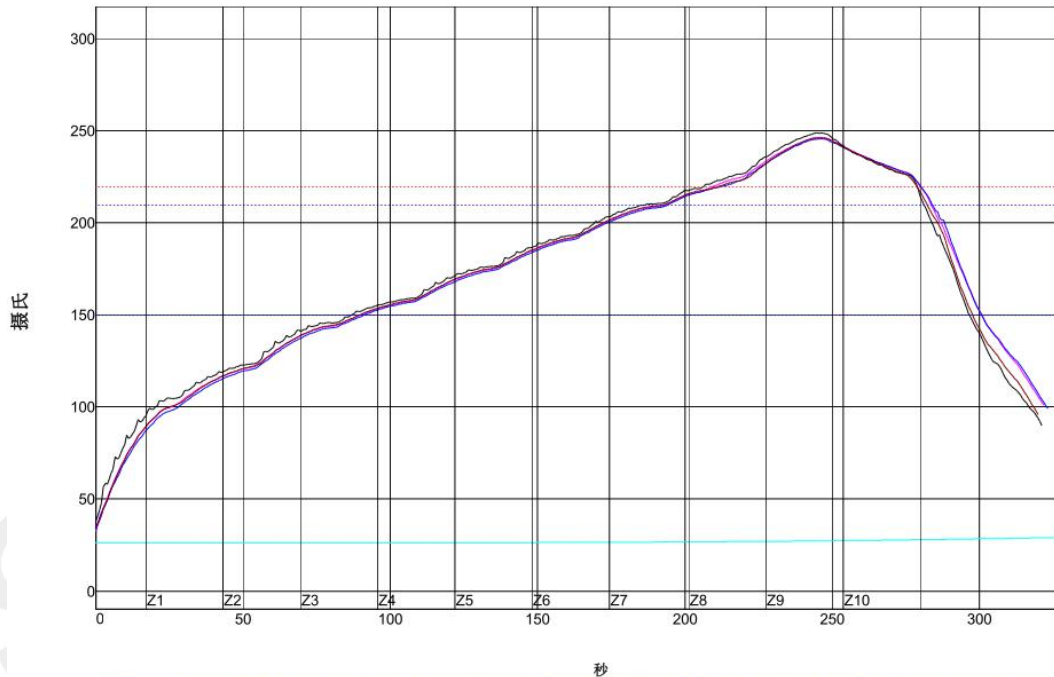

PWI= 80%	最高上升斜率	最高下降斜率	恒温时间150至210C	回流时间 /220C	最高温度
2	2.62 62%	-3.23 18%	103.87	70.54 -8%	246.56 31%
3	2.55 55%	-3.22 19%	103.42	67.24 -42%	245.83 17%
5	2.65 65%	-3.73 -15%	100.02	72.24 -2%	249.01 80%
6	2.56 56%	-3.50 0%	103.49	67.06 -43%	246.36 27%
温差	0.10	0.51	3.85	5.18	3.18

制程界限:

锡膏: M705-GRN360				
统计数名称	最低界限	最高界限	单位	
最高温度上升斜率 (目标=2.0) (计算斜率的时间距离= 25 秒)	1	3	度/秒	
最高温度下降斜率 (计算斜率的时间距离= 25 秒)	-5	-2	度/秒	
恒温时间150-210摄氏度	90	120	秒	
回流以上时间 - 220摄氏度	60	85	秒	
最高温度	240	250	度 摄氏	

Figure 49: Recommend Temperature Curve of Reflow Furnace

NOTE

Please review the “Module Secondary-SMT-UGD” for detailed information on the module transmission, manufacture, and production.

9.6 Moisture Sensitivity Level (MSL)

The SIM8970x module complies with the MSL Class 3. The dry packaging shall comply with J-STD-020C specification according to IPC/JEDEC standard when the environmental temperature is under 30 degree and the relative humidity is less than 60%. The shelf life of the unpacking products shall be at least 6 months in the area where the environmental temperature is under 40 degree and the relative humidity is less than 90%.

Table 53: Moisture Sensitivity Level Classification

Classification	Factory Environment $\leq +30^{\circ}\text{C}/60\%\text{RH}$
1	Indefinite Shelf Life Environment $\leq +30^{\circ}\text{C}/85\%\text{RH}$
2	1 Year
2a	4 Weeks
3	168 Hours
4	72 Hours
5	48 Hours
5a	24 Hours
6	Attaching after forced baking After baking, the module must be pasted within the time limit specified on the label

9.7 Baking Requirements

SIM8970 series module should be full baked before reflow welding due to the moisture sensitivity level. Otherwise, the module may be permanently damaged during reflow welding. SIM8970x series module shall be baked for 192 hours in a low-temperature container with the temperature at $40^{\circ}\text{C} \pm 5^{\circ}\text{C} / -0^{\circ}\text{C}$ and a relative humidity of less than 5%. Or the module shall be baked for 4 hours in a high-temperature container with a temperature of $120^{\circ}\text{C} \pm 5^{\circ}\text{C}$. Note that the tray could not resistant to high temperature. The user should take the module out of the tray for baking, otherwise the tray may be damaged by high temperature.

Table 54: Baking Requirements

Optional Baking Condition	Baking Period
$40^{\circ}\text{C} \pm 5^{\circ}\text{C}$, <5% RH	192 Hours
$120^{\circ}\text{C} \pm 5^{\circ}\text{C}$, <5% RH	4 Hours

9.8 Packaging

The SIM8970x module offers the following packaging size.

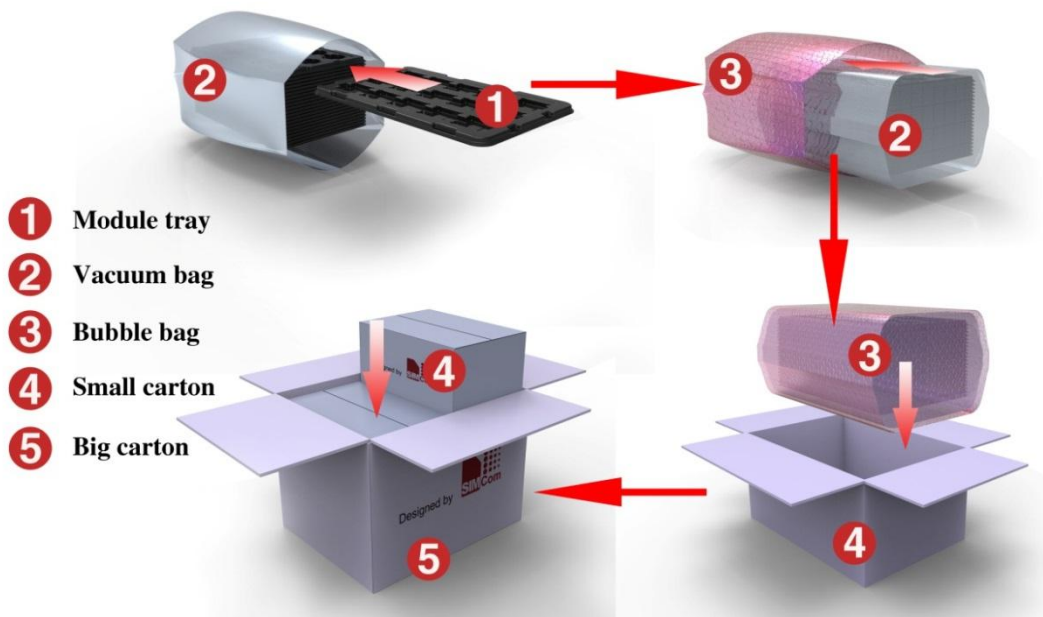

Figure 50: Packaging Diagram

The module tray of the SIM8970x series module is showing as follows.

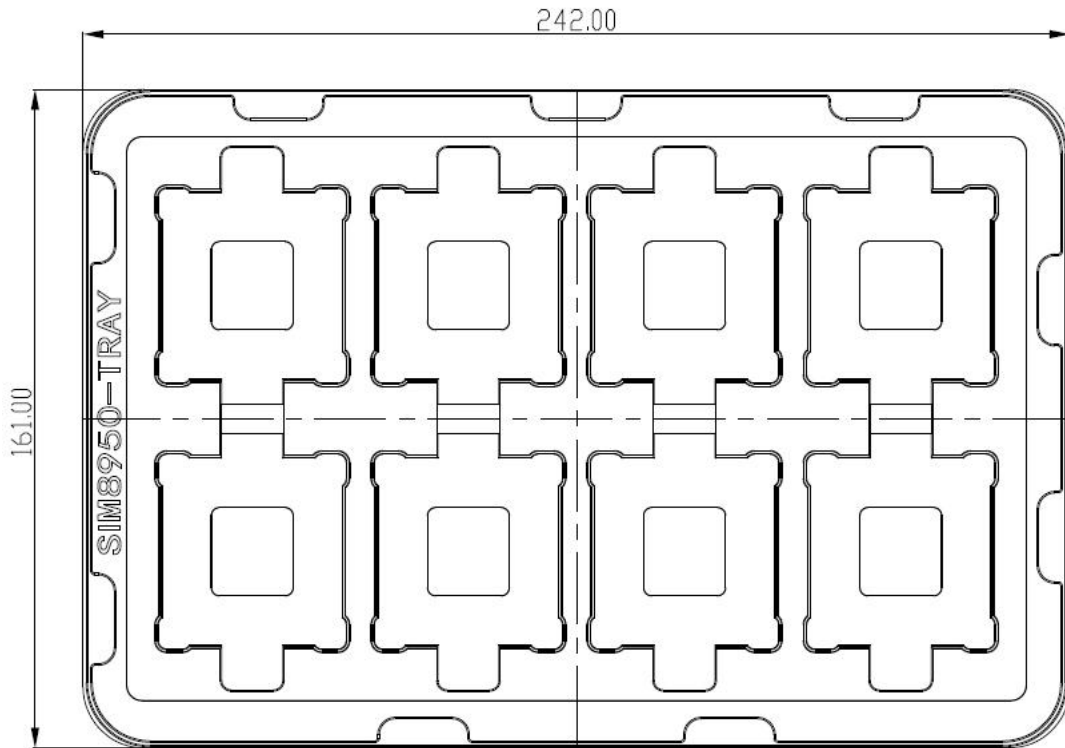

Figure 51: Module Tray Size

Table 55: Module Tray Size

Length ($\pm 3\text{mm}$)	Width ($\pm 3\text{mm}$)	Standard Packaging Num
242.0	161.0	8

The small carton size of the SIM8970x series module is showing as follows.

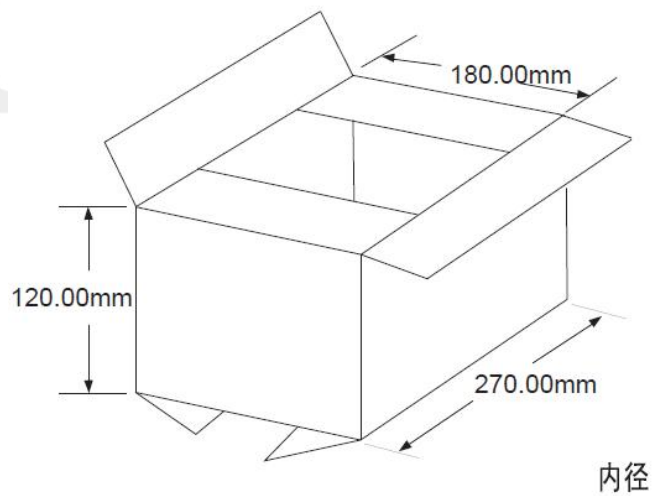

Figure 52: Small Carton Size

Table 56: Small Carton Size

Length ($\pm 10\text{mm}$)	Width ($\pm 10\text{mm}$)	Height ($\pm 10\text{mm}$)	Standard Packaging
270	180	120	8*19-2=150

The big carton size of the SIM8970x series module is showing as follows.

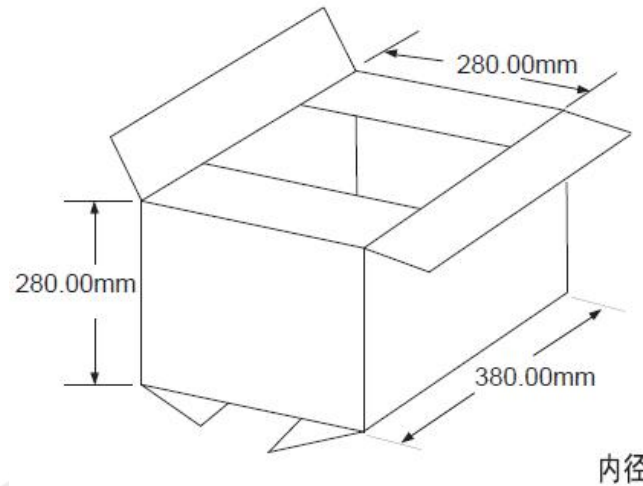

Figure 53: Big Carton Size

Table 57: Big Carton Size

Length ($\pm 10\text{mm}$)	Width ($\pm 10\text{mm}$)	Height ($\pm 10\text{mm}$)	Standard Packaging
380	280	280	150*4=600

10 Recommend Devices

Table 58: Recommend Cameras Lists

Direction	Resolution	Model	Vendor
Front/Back	2M	GC2145	GALAXYCORE
Front	5M	OV5675	OmniVision
		OV5695	OmniVision
		S5K5E9	SAMSUNG
	8M	OV8856	OmniVision
Back	12M	OV12A	OmniVision
		S5K2L7SA03	SAMSUNG
		IMX362	SONY
		MX486	SONY
	13M	AR1337	ON Semiconductor
		OV13855	OmniVision
		OV13880	OmniVision
		S5K3L6	SAMSUNG
		S5K3M3SM24	SAMSUNG
		IMX258(PDAF)	SONY
Front	16M	HR1630	Huai'an imaging equipment manufacturing Co., Ltd
		OV16B10	OmniVision
		OV16885	OmniVision
		OV16885-4C	OmniVision
		S5K3P8SP	SAMSUNG
Back		S5K3P8SX	SAMSUNG
Front	20M	OV20880-4C	OmniVision
		S5K2T7SP	SAMSUNG
Back		IMX350	SONY
		IMX376	SONY
	23M	IMX318	SONY

Table 59: Recommend Screen

Model	Vendor	Resolution	Glass	Size
ST7703 -TDO-0545F71958	Truly	FHD	TFT	5.45"

Table 60: Recommend Gyroscope Sensors Lists

No.	Part Number	Vendor	Accelerometer	Gyroscope
1	BMA222E	Bosch	√	√
2	BMA250E	Bosch	√	√
3	BMA253	Bosch	√	√
4	BMA255	Bosch	√	√
5	BMG160	Bosch		√
6	BMI120	Bosch	√	√
7	BMI160	Bosch	√	√
8	BMI260	Bosch	√	√
9	BMI27	Bosch	√	√
10	BMX160	Bosch	√	√
11	ICM-20600	InvenSense	√	√
12	ICM-20602	InvenSense	√	√
13	ICM-20607	InvenSense	√	√
14	ICM-20608-D	InvenSense	√	√
15	ICM-20609	InvenSense	√	√
16	ICM-20621	InvenSense	√	√
17	ICM-20622	InvenSense	√	√
18	ICM-20626	InvenSense	√	√
19	ICM-20690	InvenSense	√	√
20	ICM-40602	InvenSense	√	√
21	ICM-40604	InvenSense	√	√
22	ICM-40605	InvenSense	√	√
23	ICM-42602	InvenSense	√	√
24	ICM-42605	InvenSense	√	√
25	ICM-42605-M	InvenSense	√	√
26	ICM-42608	InvenSense	√	√
27	LSM6DS3TR	ST	√	√
28	LSM6DS3TR-C	ST	√	√
29	LSM6DSLTR	ST	√	√
30	LSM6DSM	ST	√	√
31	LSM6DSMTR	ST	√	√

Table 61: Recommend Geomagnetism Sensors Lists

No.	Part Number	Vendor
1	AK09911C	AKM
2	AK09915C	AKM

3	AK09915D	AKM
4	AK09916C	AKM
5	AK09918C	AKM
6	HSCDTD008A	Alps
7	BMM150	Bosch
8	BMM160	Bosch
9	GMC306	Globalmems
10	IST8305	iSentek
11	IST8306	iSentek
12	IST8307	iSentek
13	IST8310	iSentek
14	MXG4300	MagnaChip
15	MMC3530	MEMSIC
16	MMC3630	MEMSIC
17	MMC3630KJ	MEMSIC
18	MMC5603NJ	MEMSIC
19	STM350MC	Senodia
20	STM480MW	Senodia
21	LIS2MDL	ST
22	AF6133	Voltafield
23	AF6133E	Voltafield
24	AF8133J	Voltafield
25	AF9133	Voltafield
26	YAS539	Yamaha

Table 62: Recommend Light Sensors Lists

No.	Part Number	Vendor	Proximity	Ambient Light
1	TMD26203	ams	√	
2	TMG49033	ams	√	√
2	CM36686	Capella	√	√
3	AP3426	Dyna Image	√	√
4	EPL2590KTWJP	Elan	√	√
5	MN66213	Elan	√	√
6	LTR-578ALS	Lite-On	√	√
7	RPR-0521RS	ROHM	√	√
8	RPR-0531	ROHM	√	√
9	RPR-0531RS	ROHM	√	√
10	STK2232	Sensortek	√	√
11	STK3311	Sensortek	√	√
12	STK3321	Sensortek	√	√

13	STK3327	Sensortek	√	√
14	STK3328	Sensortek	√	√
15	STK3332	Sensortek	√	√
16	STK3335	Sensortek	√	√
17	STK3338	Sensortek	√	√
18	V2000	Sensortek	√	√
19	PA22401001	TXC	√	
20	PA22A00001	TXC	√	√

Table 63: Recommend Pressure Sensors Lists

No.	Part Number	Vendor
1	BME680	Bosch
2	BMP280	Bosch
3	BMP285	Bosch
4	BMP380	Bosch
5	ICP-10100	InvenSense
6	ICP-10101	InvenSense
7	ICP-10110	InvenSense
8	ICP-10111	InvenSense
9	2SMPB-02B	omron
10	2SMPB-02E	omron
11	BM1383AGLV	ROHM
12	LPS22HB	ROHM
13	LPS22HBTR	ROHM
14	LPS22HH	ROHM

11 Appendix

11.1 Relative Documents

Table 64: Relative Documents

No.	Document Name	Description
[1]	GSM 07.07 :	Digital cellular telecommunications (Phase 2+); AT command set for GSM Mobile Equipment (ME)
[2]	GSM 07.10 :	Support GSM 07.10 multiplexing protocol
[3]	GSM 07.05 :	Digital cellular telecommunications (Phase 2+); Use of Data Terminal Equipment – Data Circuit terminating Equipment (DTE – DCE) interface for Short Message Service (SMS) and Cell Broadcast Service (CBS)
[4]	GSM 11.14 :	Digital cellular telecommunications system (Phase 2+); Specification of the SIM Application Toolkit for the Subscriber Identity Module – Mobile Equipment (SIM – ME) interface
[5]	GSM 11.11 :	Digital cellular telecommunications system (Phase 2+); Specification of the Subscriber Identity Module – Mobile Equipment (SIM – ME) interface
[6]	GSM 03.38 :	Digital cellular telecommunications system (Phase 2+); Alphabets and language-specific information
[7]	GSM 11.10	Digital cellular telecommunications system (Phase 2); Mobile Station (MS) conformance specification; Part 1: Conformance specification
[8]	3GPP TS 51.010-1	Digital cellular telecommunications system (Release 5); Mobile Station (MS) conformance specification
[9]	3GPP TS 34.124	Electromagnetic Compatibility (EMC) for mobile terminals and ancillary equipment.
[10]	3GPP TS 34.121	Electromagnetic Compatibility (EMC) for mobile terminals and ancillary equipment.
[11]	3GPP TS 34.123-1	Technical Specification Group Radio Access Network; Terminal conformance specification; Radio transmission and reception (FDD)
[12]	3GPP TS 34.123-3	User Equipment (UE) conformance specification; Part 3:

		Abstract Test Suites.
[13]	EN 301 908-02 V2.2.1	Electromagnetic compatibility and Radio spectrum Matters (ERM); Base Stations (BS) and User Equipment (UE) for IMT-2000. Third Generation cellular networks; Part 2: Harmonized EN for IMT-2000, CDMA Direct Spread (UTRA FDD) (UE) covering essential requirements of article 3.2 of the R&TTE Directive
[14]	EN 301 489-24 V1.2.1	Electromagnetic compatibility and Radio Spectrum Matters (ERM); Electromagnetic Compatibility (EMC) standard for radio equipment and services; Part 24: Specific conditions for IMT-2000 CDMA Direct Spread (UTRA) for Mobile and portable (UE) radio and ancillary equipment
[15]	IEC/EN60950-1(2001)	Safety of information technology equipment (2000)
[16]	GCF-CC V3.23.1	Global Certification Forum - Certification Criteria
[17]	2002/95/EC	Directive of the European Parliament and of the Council of 27 January 2003 on the restriction of the use of certain hazardous substances in electrical and electronic equipment (RoHS)

11.2 Terms & Abbreviations

Table 65: Terms & Abbreviations





Terms	Description
ADC	Analog-to-Digital Converter
AMR	Adaptive Multi-Rate
BOM	Bill of materials
bps	Bits per second
BT	Bluetooth
CDMA	Code division multiple access
CS	Coding Scheme
CSD	Circuit Switched Data
CSI	Camera serial interface
CTS	Clear to Send
DAC	Digital-to-analog converter
DDR	Double data rate
DSDA	Dual SIM dual active
DSDS	Dual SIM dual standby
DSP	Digital signal processor
DTE	Data Terminal Equipment (typically computer, terminal, printer)

DTR	Data Terminal Ready
DTX	Discontinuous Transmission
EFR	Enhanced Full Rate
EGSM	Enhanced GSM
ESD	Electrostatic Discharge
ESR	Effective series resistance
ETS	European Telecommunication Standard
EVDO	Evolution data optimized
FDD	Frequency division duplex
FR	Full Rate
GNSS	Global navigation satellite system
GPIO	General-purpose input/output
GPRS	General Packet Radio Service
GPU	Graphics processing unit
GSM	Global Standard for Mobile Communications
HR	Half Rate
HSPA	High-speed packet access
I2C	Inter-integrated circuit
IMEI	International Mobile Equipment Identity
ISP	Image signal processing
Kbps	kilobits per second
LCD	Liquid crystal display
LDO	Low dropout (linear regulator)
LPDDR	Low-power DDR
MIC	Microphone
MIPI	Mobile industry processor interface
PA	Power amplifier
PBCCH	Packet Broadcast Control Channel
PCB	Printed Circuit Board
PCL	Power Control Level
PCS	Personal Communication System, also referred to as GSM 1900
PDU	Protocol Data Unit
RF	Radio Frequency
PM	Power management
RoHS	Restriction of hazardous substances
PPP	Point-to-point protocol
PWM1	Pulse-width modulator
RMS	Root Mean Square (value)
RTC	Real-time clock
RX	Receive Direction
SD	Secure digital

SDC	Secure digital controller
SIM	Subscriber Identification Module
SMS	Short Message Service
SMT	Surface mount technology
SPI	Serial peripheral interface
TDD	Time Division Distortion
TE	Terminal Equipment, also referred to as DTE
TX	Transmit Direction
UART	Universal Asynchronous Receiver & Transmitter
UIM	User identity module
URC	Unsolicited Result Code
USB	Universal serial bus
USSD	Unstructured Supplementary Service Data
WCDMA	Wideband code division multiple access
WCN	Wireless connectivity network
WLAN	Wireless local area network

11.3 Safety Caution

Table 66: Safety Caution

Marks	Requirements
	When in a hospital or other health care facility, observe the restrictions about the use of mobiles. Switch the cellular terminal or mobile off, medical equipment may be sensitive and not operate normally due to RF energy interference.
	Switch off the cellular terminal or mobile before boarding an aircraft. Make sure it is switched off. The operation of wireless appliances in an aircraft is forbidden to prevent interference with communication systems. Forgetting to think much of these instructions may impact the flight safety, or offend local legal action, or both.
	Do not operate the cellular terminal or mobile in the presence of flammable gases or fumes. Switch off the cellular terminal when you are near petrol stations, fuel depots, chemical plants or where blasting operations are in progress. Operation of any electrical equipment in potentially explosive atmospheres can constitute a safety hazard.
	Your cellular terminal or mobile receives and transmits radio frequency energy while switched on. RF interference can occur if it is used close to TV sets, radios, computers or other electric equipment.



Road safety comes first! Do not use a hand-held cellular terminal or mobile when driving a vehicle, unless it is securely mounted in a holder for hands free operation. Before making a call with a hand-held terminal or mobile, park the vehicle.



GSM cellular terminals or mobiles operate over radio frequency signals and cellular networks and cannot be guaranteed to connect in all conditions, especially with a mobile fee or an invalid SIM card. While you are in this condition and need emergent help, please remember to use emergency calls. In order to make or receive calls, the cellular terminal or mobile must be switched on and in a service area with adequate cellular signal strength.

Some networks do not allow for emergency call if certain network services or phone features are in use (e.g. lock functions, fixed dialing etc.). You may have to deactivate those features before you can make an emergency call.

Also, some networks require that a valid SIM card be properly inserted in the cellular terminal or mobile.

SIMCom
Confidential