

AHI-JS-DR-01-256

客户用图

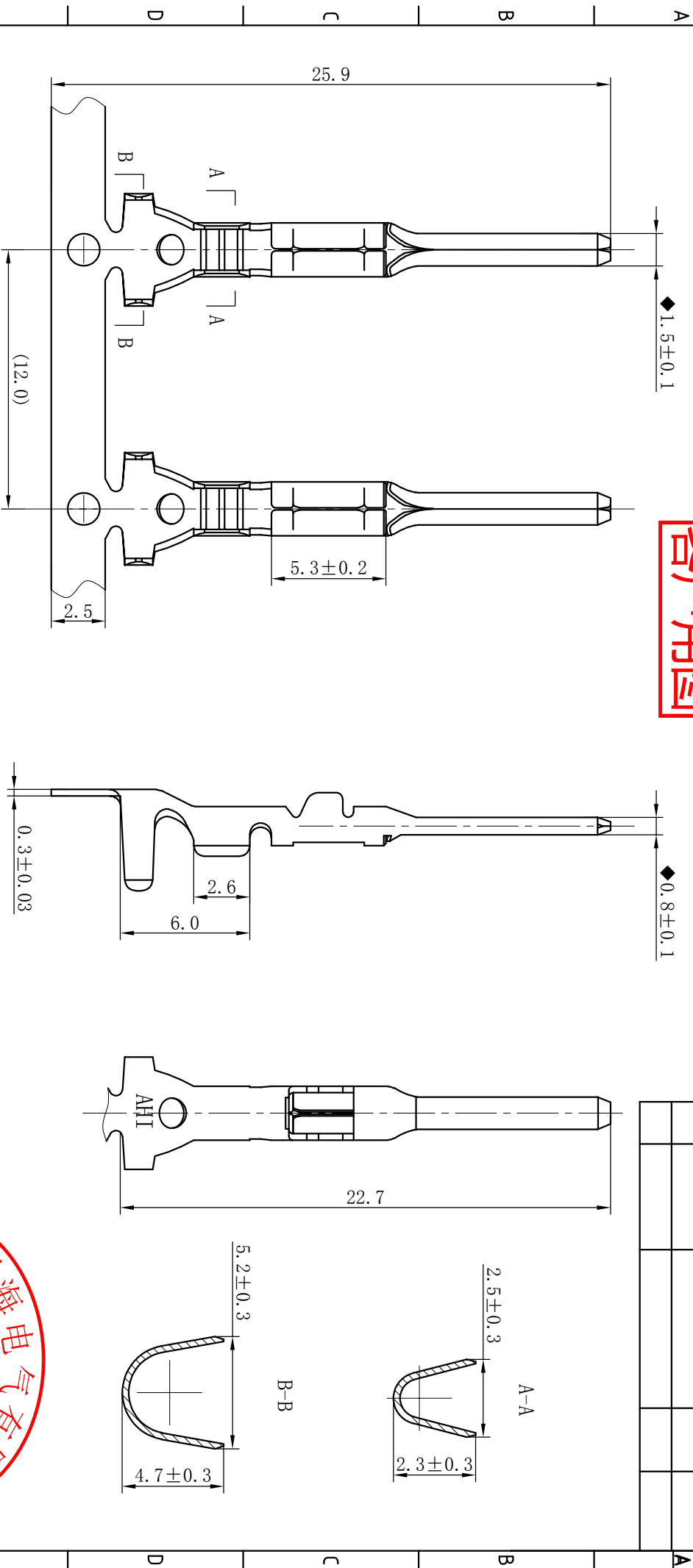

标记 MARK	ECN NO.	修订内容 DESCRIPTION	签名 DWN.	日期 DATE

技术要求:

Technical requirements:

1. 冲件表面不允许有明显划伤、裂痕、变形等冲压缺陷
The punching surface is not allowed to have obvious scratch, crack, deformation and other stamping defects
2. 表面处理: 镀锡 2~5 μm
Tin Plating thickness 2~5 μm
3. 适用导线: 0.35-0.5mm²
Wire range: 0.35-0.5mm²
4. "◆"为特殊特性
- ◆ "Special Characteristics
5. 未注公差按GB/T15055-2007-m
No Tolerances GB/T15055-2007-m

未注尺寸公差表

NO. TOLERANCES GB/T15055-2007-m

尺寸范围 DIM. RANGE	尺寸公差 DIM. TOLERANCES
0.5~3	±0.20
>3~6	±0.30
>6~30	±0.40
>30~120	±0.50

镀涂 Finish	镀锡 Tin-Plating
产品材料 Material	黄铜 BRASS t0.3
产品名称 Name	端子 Terminal
产品型号 Part No.	AH611-1.5X0.8A
客户型号 Article No.	
重量 Weight	

温州奥海电气有限公司
Wenzhou Aohai Electric Co., Ltd.

设计
DRAWN BY
2018.4.7

审核
CHECKED BY
2018.4.7

批准
APPROVED BY
2018.4.7

技术部

版次 REV.	第一视角 FIRST ANGLE PROJECTION	比例 SCALE	单位 UNIT	页数 PAGE
1.0		2:1	mm	1/1