



# Application Note

## SIM5320 TO SIM7600 Series MIGRATION GUIDE



FILE

U

<b>Document Title</b>	SIM5320 TO SIM7600 Series MIGRATION GUIDE
<b>Version</b>	1.00
<b>Date</b>	2019-08-13
<b>Status</b>	Released
<b>Document Control ID</b>	SIM5320 TO SIM7600 Series MIGRATION GUIDE_V1.00

### **General Notes**

SIMCom offers this information as a service to its customers, to support application and engineering efforts that use the products designed by SIMCom. The information provided is based upon requirements specifically provided to SIMCom by the customers. SIMCom has not undertaken any independent search for additional relevant information, including any information that may be in the customer's possession. Furthermore, system validation of this product designed by SIMCom within a larger electronic system remains the responsibility of the customer or the customer's system integrator. All specifications supplied herein are subject to change.

### **Copyright**

This document contains proprietary technical information which is the property of SIMCom Limited, copying of this document and giving it to others and the using or communication of the contents thereof, are forbidden without express authority. Offenders are liable to the payment of damages. All rights reserved in the event of grant of a patent or the registration of a utility model or design. All specification supplied herein are subject to change without notice at any time.

**Copyright © Shanghai SIMCom Wireless Solutions Ltd. 2019**

## Contents

<b>Revision History .....</b>	<b>6</b>
<b>1 Introduction .....</b>	<b>7</b>
<b>2 Pin Configuration .....</b>	<b>7</b>
<b>3 Recommended Footprint .....</b>	<b>9</b>
<b>4 Hardware Reference Design .....</b>	<b>11</b>
4.1 Power Supply .....	11
4.2 USB Interface .....	12
4.3 Network Status Indication.....	12
4.4 Power on/off circuit .....	13
4.5 USIM Interface .....	13
4.6 UART Interface.....	14
4.7 3G/4G RF Interface .....	15
4.8 SDIO Interface.....	16
4.9 SDC Interface .....	16
4.10 Dedicated Pins for SIM7600.....	17
<b>5 Appendix .....</b>	<b>18</b>
5.1 Related documents.....	18
5.2 Terms and Abbreviation .....	18

## Table Index

Table 1: The Differences of Pin Assignment in SIM7600 and SIM5320 .....	8
Table 2: Dedicated Pins Description for SIM7600.....	17
Table 3: Related documents .....	18
Table 4: Terms and Abbreviations.....	18

SIMCOM CONFIDENTIAL FILE

## Figure Index

Figure 1: SIM7600 and SIM5320 Pin Assignment .....	7
Figure 2: SIM5320 footprint recommendation (Unit: mm).....	9
Figure 3: SIM7600 footprint recommendation (Unit: mm).....	10
Figure 4: Power input Reference Circuit of SIM7600 and SIM5320.....	11
Figure 5: Reference circuit of the LDO power supply .....	11
Figure 6: USB interface .....	12
Figure 7: USB interface .....	12
Figure 8: Application circuit .....	13
Figure 9: Power on/off circuit .....	13
Figure 10: USIM interface reference circuit .....	14
Figure 11: Reference circuit of level shift.....	14
Figure 12: SIM5320 Antenna matching circuit.....	15
Figure 13: SIM7600 Antenna matching circuit.....	15
Figure 14: SIM7600 WIFI solution.....	16
Figure 15: SIM7600 SDC interface for SD card.....	16
Figure 16: SIM7600 SDC interface for eMMC .....	17

## Revision History

Data	Version	Description of change	Author
2019-07-31	1.00	Original	Honggang Ma

SIMCOM CONFIDENTIAL FILE

# 1 Introduction

This document is targeted for customers to understand the differences between the SIM7600 and SIM5320. Users can use SIM7600 or SIM5320 module to design and develop applications quickly.

# 2 Pin Configuration

The following figure shows the pin assignment of SIM7600 and SIM5320.

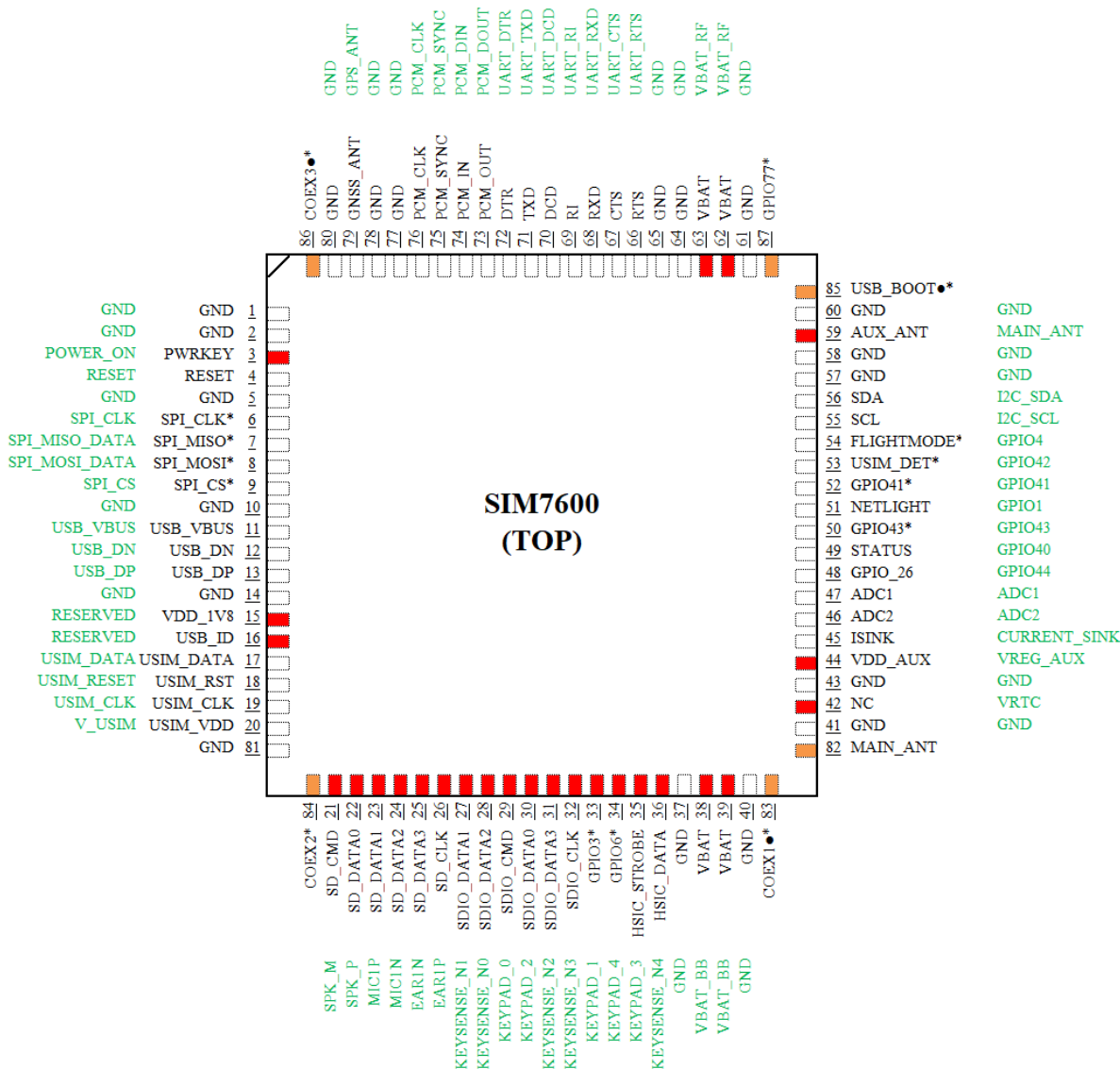

Figure 1: SIM7600 and SIM5320 Pin Assignment

**NOTE:**

1. The pin names of SIM5320 are marked with green color.
2. There are some differences of pin assignment between SIM7600 and SIM5320, marked with red color.

3. SIM7600 has 6 more pins than SIM5320 marked with orange color.

**Table 1: The Differences of Pin Assignment in SIM7600 and SIM5320**

Pin No.	SIM7600 Pin name	SIM5320 Pin name	Description
3	PWRKEY	POWER_ON	SIM7600: 0.8V when the VBAT appears. SIM5320: 1.8V when the VBAT appears.
15	VDD_1V8	RESERVED	SIM7600: VIO of SIM7600 SIM5320: RESERVED
16	USB_ID	RESERVED	SIM7600: USB_ID for OTG usage SIM5320: RESERVED
21	SD_CMD	SPK_M	SIM7600: SDC interface (need software support)  SIM5320: Audio interface
22	SD_DATA0	SPK_P	
23	SD_DATA1	MIC1P	
24	SD_DATA2	MIC1N	
25	SD_DATA3	EAR1N	
26	SD_CLK	EAR1P	
27	SDIO_DATA1	KEYSENSE_N1	SIM7600: SDIO can work with wifi module; also can be used as keypad interface.(need software support)  SIM5320: keypad interface.
28	SDIO_DATA2	KEYSENSE_N0	
29	SDIO_CMD	KEYPAD_0	
30	SDIO_DATA0	KEYPAD_2	
31	SDIO_DATA3	KEYSENSE_N2	
32	SDIO_CLK	KEYSENSE_N3	
33	GPIO3	KEYPAD_1	SIM7600: GPIO
34	GPIO6	KEYPAD_4	SIM5320: keypad interface.
35	HSIC_STROBE	KEYPAD_3	SIM7600: HSIC interface (need software support)
36	HSIC_DATA	KEYSENSE_N4	SIM5320: keypad interface.
38	VBAT	VBAT_BB	SIM7600: power for the whole module
39	VBAT	VBAT_BB	SIM5320:power for the BB part
42	NC	VRTC	SIM7600: no connection SIM5320:backup battery interface
44	VDD_AUX	VREG_AUX	SIM7600: 2.85V by default SIM5320: 2.6V by default
59	AUX_ANT	MAIN_ANT	SIM7600: auxiliary antenna SIM5320:main antenna
62	VBAT	VBAT_RF	SIM7600: power for the whole module
63	VBAT	VBAT_RF	SIM5320:power for the RF part
82	MAIN_ANT	/	SIM7600: Main antenna
83	COEX1	/	SIM7600: GPIO
84	COEX2	/	SIM7600: GPIO
85	USB_BOOT	/	SIM7600: GPIO Can be used as force USB boot interface.



86	COEX3	/	SIM7600: GPIO
87	GPIO77	/	SIM7600: GPIO

### 3 Recommended Footprint

The recommended footprints of SIM7600 and SIM5320 are different; see the following figures for the detail.

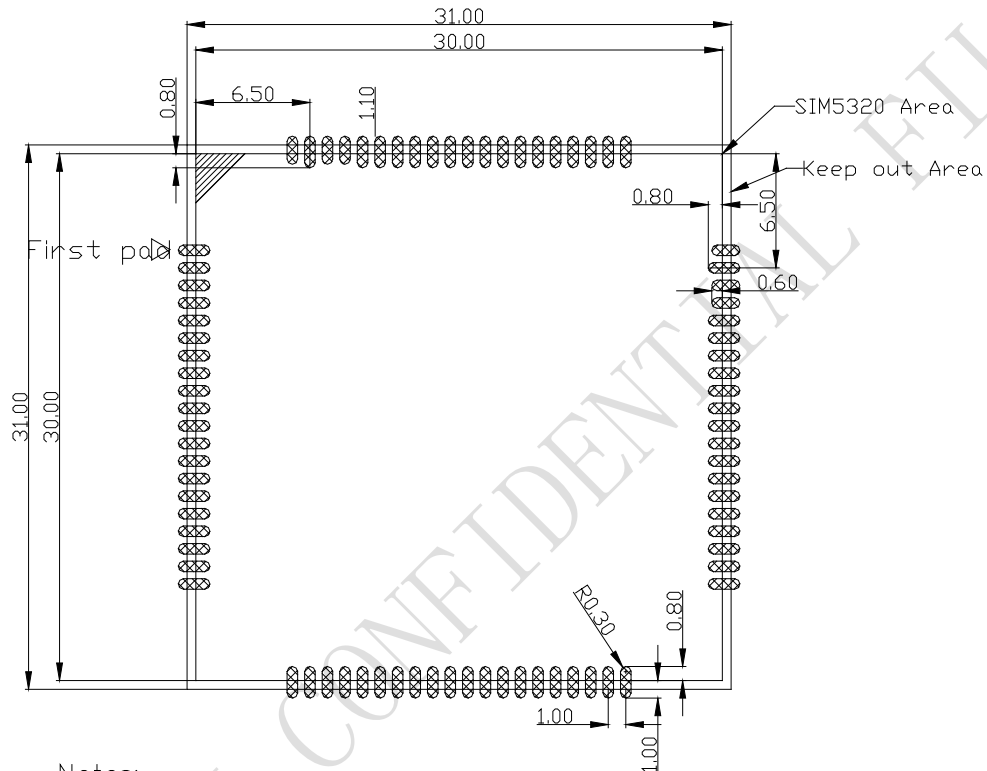

Notes:  
Silk screen and copper exposure are not allowed in the Keep out Area.

**Figure 2: SIM5320 footprint recommendation (Unit: mm)**

Recommended PCB  
footprint ourline  
(Unit:mm)

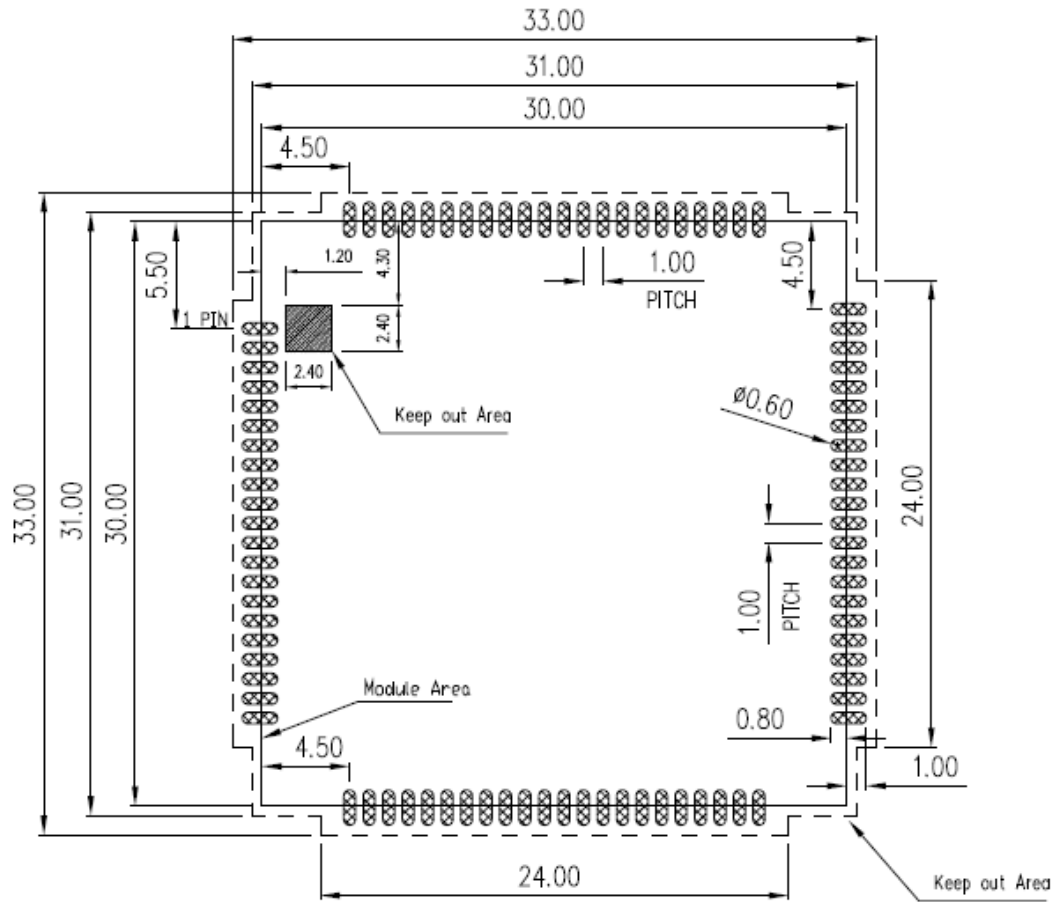

Figure 3: SIM7600 footprint recommendation (Unit: mm)

## 4 Hardware Reference Design

The following chapters describe compatible design of SIM7600 and SIM5320 on main functionalities.

### 4.1 Power Supply

The power supply pins of SIM7600 include four VBAT pins (pin 62&63, pin 38&39). VBAT directly supplies the power to RF circuit and baseband circuit. customer can only power pin38 and pin39, or can only power pin62 and pin63, for the four pins are connected inside the module.

The SIM5320 also has four VBAT pins, but the VBAT\_BB and VBAT\_RF is different network, customer must power all four pins together.

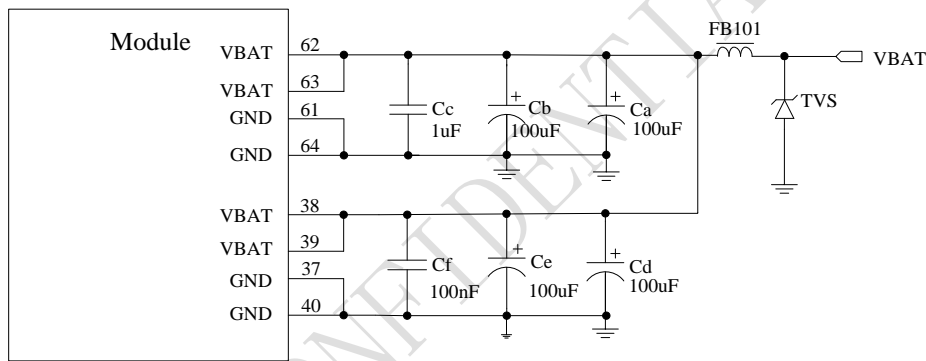

**Figure 4: Power input Reference Circuit of SIM7600 and SIM5320**

*Note: The Cd, Ce, Cb, Cc and Cf are recommended being mounted for SIM7600, but the Ca, Cb, Ce, Cc and Cf for SIM5320.*

The following figure is the reference design of +5V input power supply. The designed output for the power supply is 3.8V; here a linear regulator can be used.

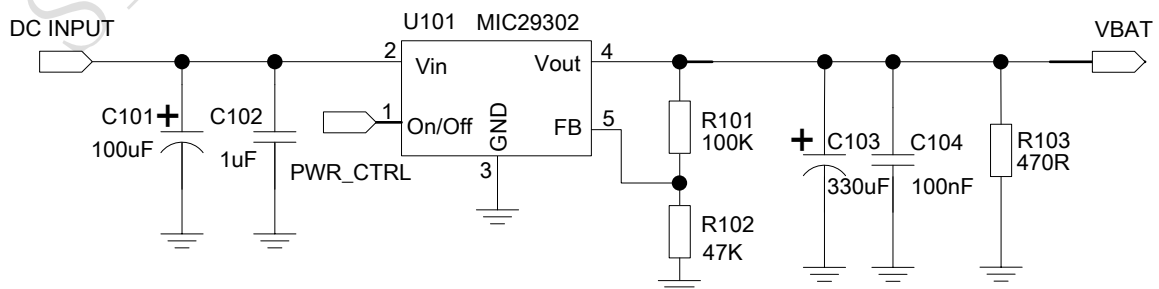

**Figure 5: Reference circuit of the LDO power supply**

In addition, in order to get a stable power source, it is suggested to use a TVS diode of which working voltage is more than 5V, see the HD document for the recommend parts.

## 4.2 USB Interface

The USB interface of SIM7600 and SIM5320 module are compliant with the USB2.0 specification as USB device. The following circuit is the reference design of USB interface.

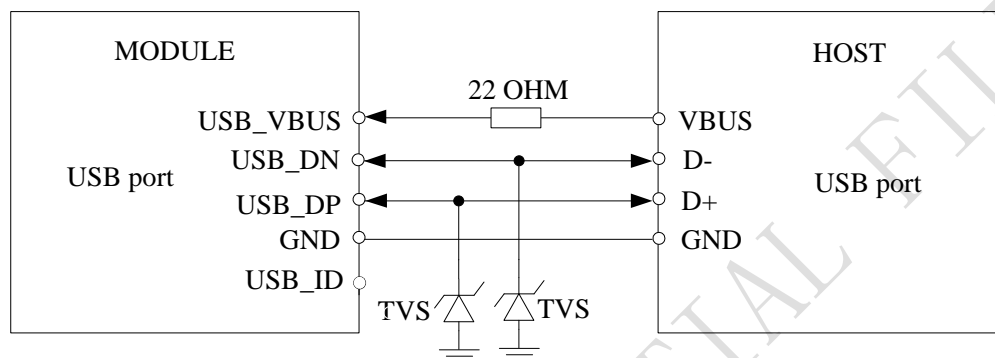

Figure 6: USB interface

*Note: As SIM7600 is peripheral (USB device), please keep USB\_ID pins open.*

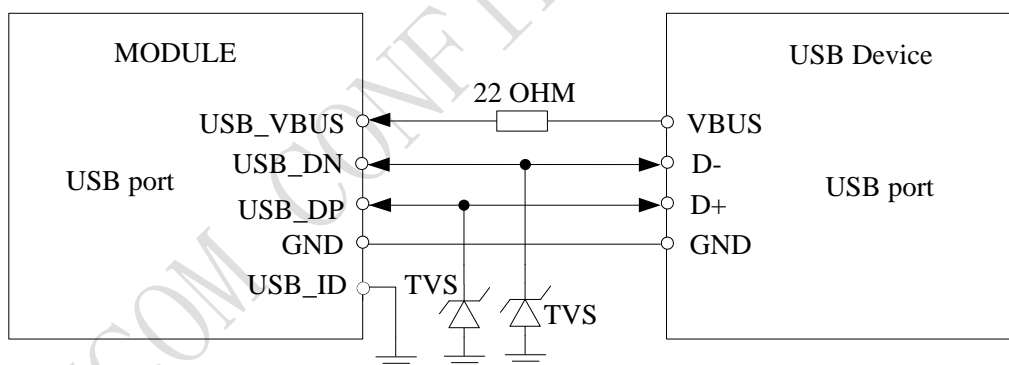

Figure 7: USB interface

*Note: As SIM7600 is USB host, please connect USB\_ID to GND directly with less than 100hm impedance to ground.*

Anyway, ESD protection component with low load capacitance value is recommended, such as ON SEMI ([www.onsemi.com](http://www.onsemi.com)) ESD9L5.0ST5G.

## 4.3 Network Status Indication

The GPIO1 on SIM53320 and NETLIGHT pin on SIM7600 can be used to drive a network status indicator LED. The following circuit is the reference design.

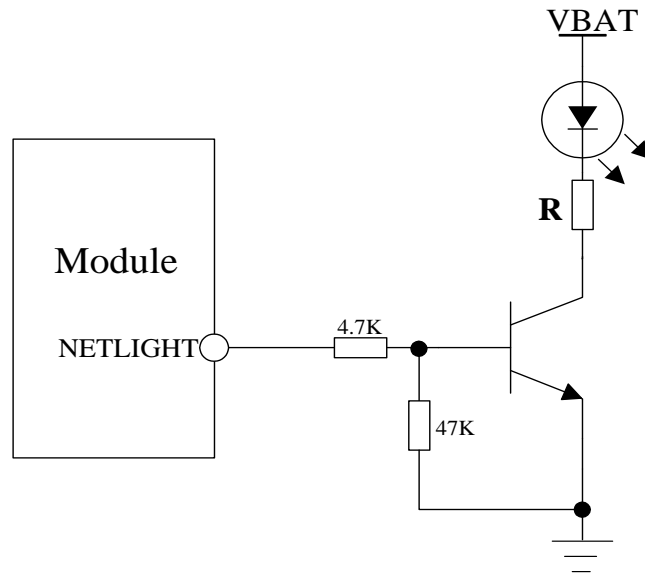

Figure 8: Application circuit

#### 4.4 Power on/off circuit

The following circuit is a reference design for SIM7600 and SIM5320 power-on/off circuit.

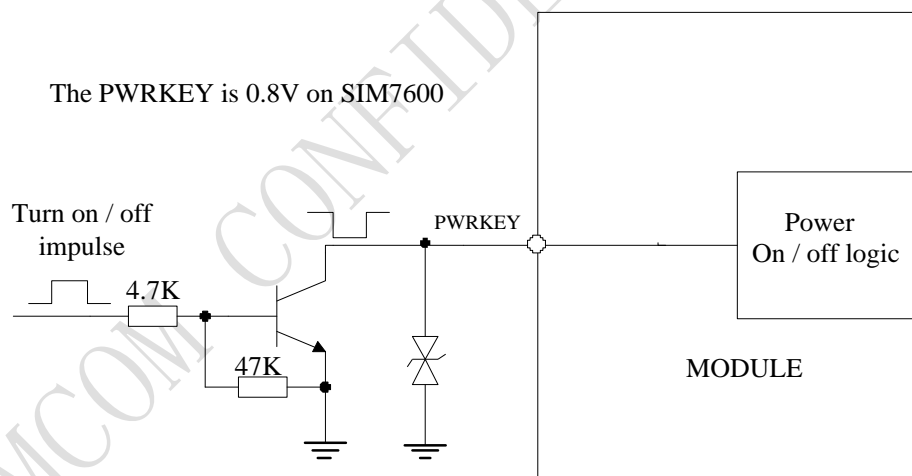

Figure 9: Power on/off circuit

**NOTE:** The high voltage of PWRKEY is 0.8V on SIM7600, and SIM5320 is 1.8V.

#### 4.5 USIM Interface

The USIM provides the required subscription verification information to allow the mobile equipment to attach to a GSM or UMTS network. Both 1.8V and 3.0V SIM Cards are supported.

It is recommended to use an ESD protection component such as ST ([www.st.com](http://www.st.com)) ESDA6V1W5. The following circuit is a reference design for SIM7600 and SIM5320 USIM circuit.

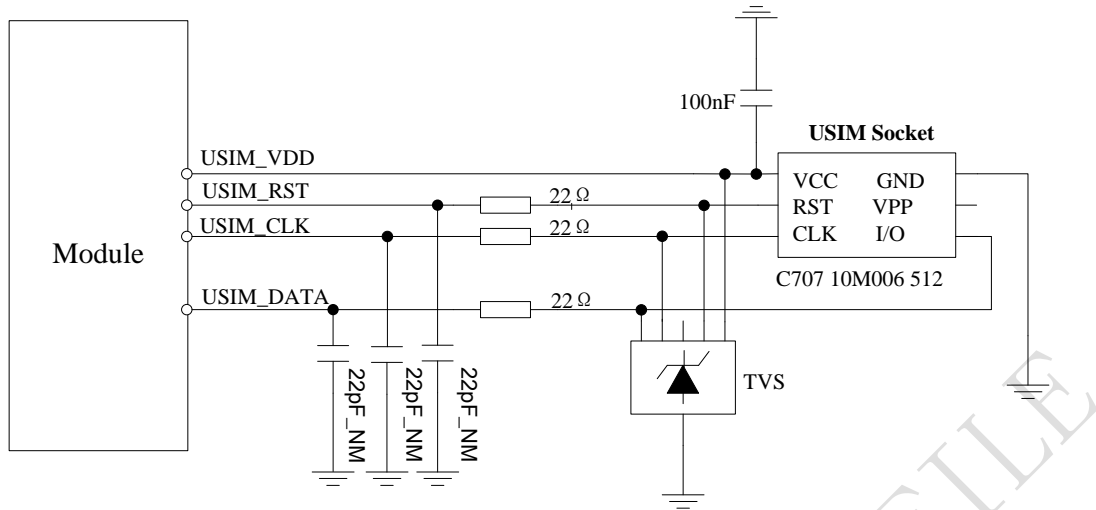

**Figure 10: USIM interface reference circuit**

#### 4.6 UART Interface

A level shifter should be used if user’s application is equipped with a 3.3V UART interface. The level shifter TXB0108RGYR provided by Texas Instruments is recommended. The reference design of the TXB0108RGYR is in the following figures.

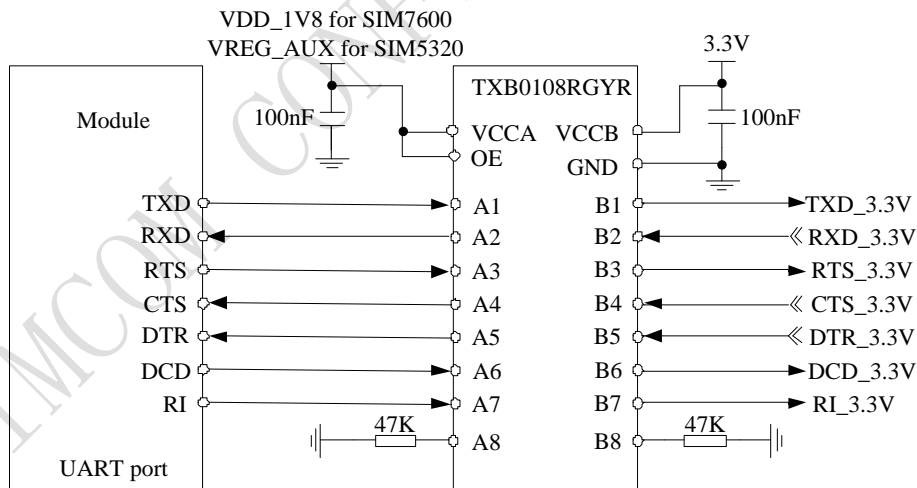

**Figure 11: Reference circuit of level shift**

### 4.7 3G/4G RF Interface

SIM7600 and SIM5320 provide antenna interfaces about 3G/4G. Customer’s antennas should be located in the host board and connected to module’s antenna pad through micro-strip line or other types of RF trace and the trace impedance must be controlled by 50Ω.

SIM7600 provides main antenna and aux antenna, and SIM5320 only provide main antenna.

The following circuit is a reference design for SIM5320 RF antenna circuit

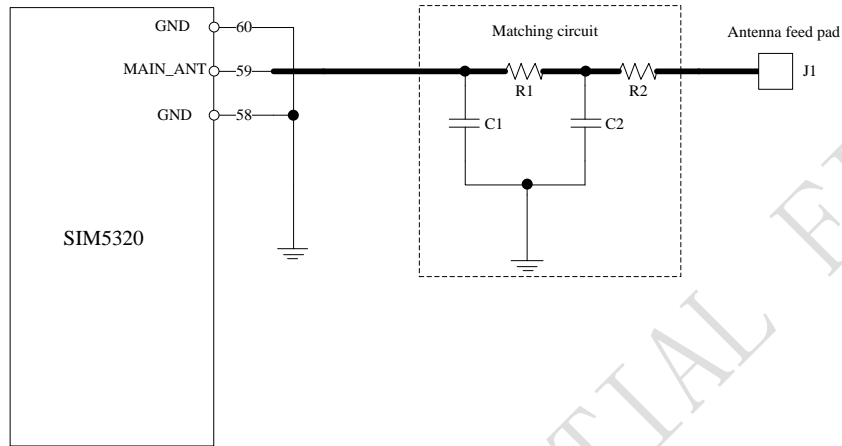

**Figure 12: SIM5320 Antenna matching circuit**

The following circuit is a reference design for SIM7600 RF antenna circuit.

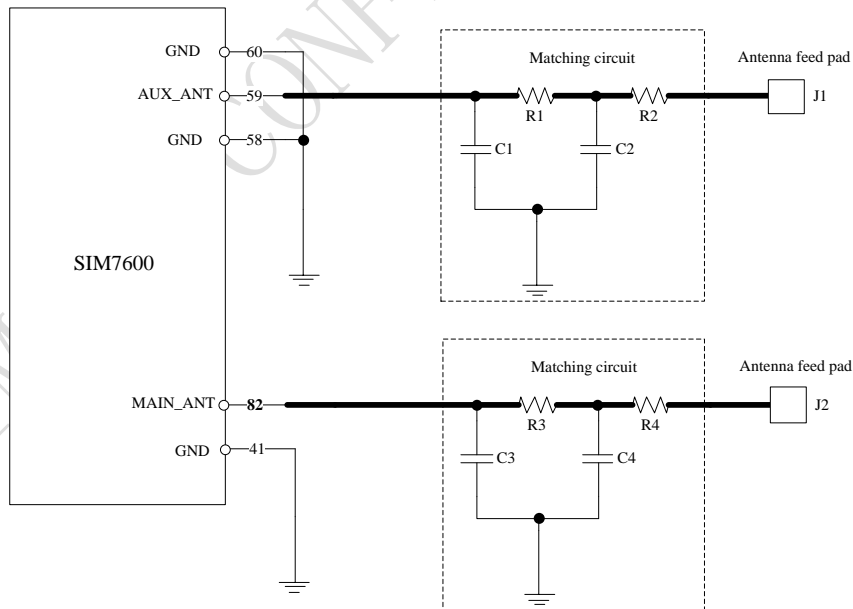

**Figure 13: SIM7600 Antenna matching circuit**

*Note: The main and auxiliary antennas of SIM7600 and SIM5320 are different.*

### 4.8 SDIO Interface

SIM7600 provides SDIO interface with clock rate up to 200 MHz and 1.8V voltage for WIFI solution, it can work with W58 module to provide Wi-Fi solution. The wifi function need software support. SIM5320 provides keypad interface relevantly.

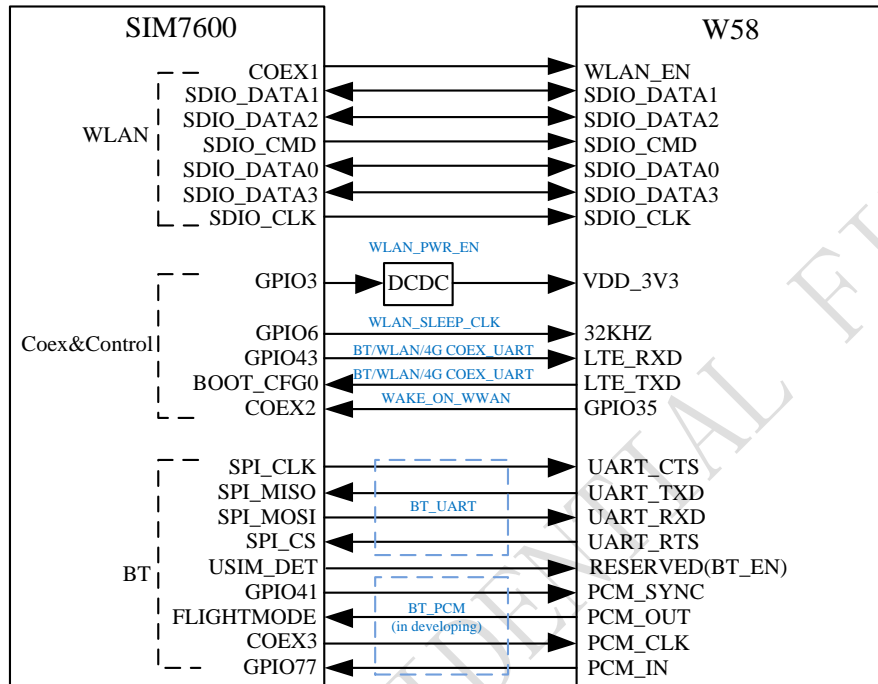

Figure 14: SIM7600 WIFI solution

### 4.9 SDC Interface

SIM7600 provides a SDC/MMC interface

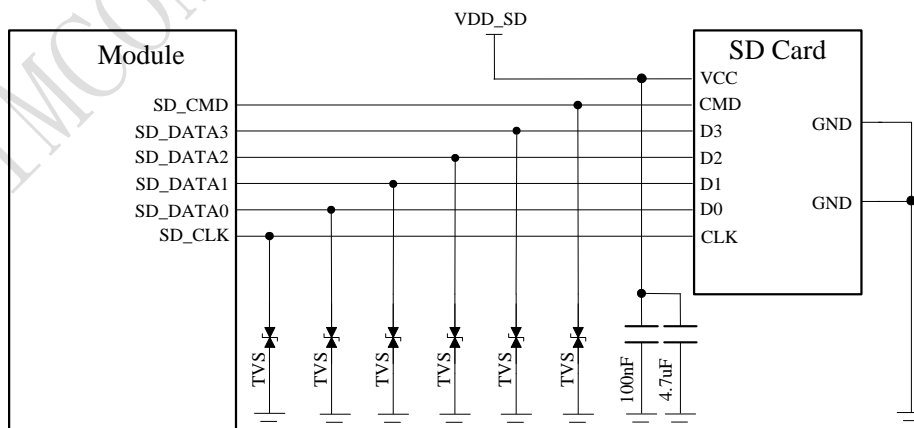

Figure 15: SIM7600 SDC interface for SD card



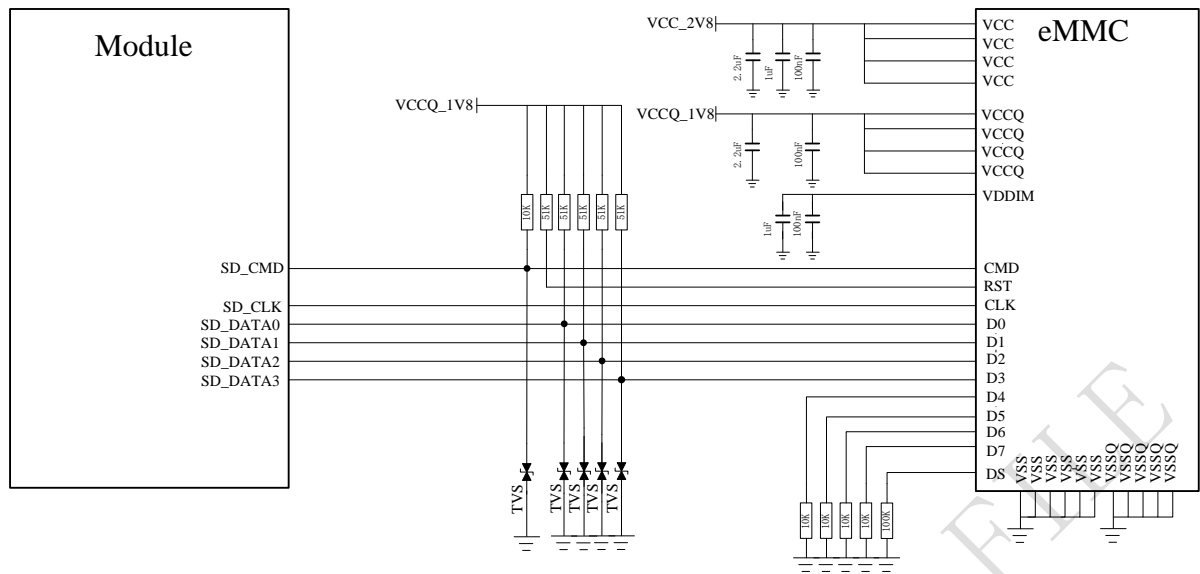

Figure 16: SIM7600 SDC interface for eMMC

#### 4.10 Dedicated Pins for SIM7600

SIM7600 provides 5 new GPIO pins for extended application.

Table 2: Dedicated Pins Description for SIM7600

Pin name	Pin No.	Function
COEX1	83	These pins can be used as GPIO after the module boot up.
COEX2	84	
USB_BOOT	85	
COEX3	86	
GPIO77	87	

## 5 Appendix

### 5.1 Related documents

**Table 3: Related documents**

SN	Document name	Remark
[1]	SIM7600_Hardware_Design	SIM7600 Hardware Design Document
[2]	SIM5320_Hardware_Design	SIM5320 Hardware Design Document

### 5.2 Terms and Abbreviation

**Table 4: Terms and Abbreviations**

Abbreviation	Description
ESD	Electrostatic Discharge
GSM	Global Standard for Mobile Communications
I2C	Inter-Integrated Circuit
PCB	Printed Circuit Board
PCS	Personal Communication System, also referred to as GSM 1900
RF	Radio Frequency
RTC	Real Time Clock
Rx	Receive Direction
SIM	Subscriber Identification Module
SPI	serial peripheral interface
UART	Universal Asynchronous Receiver & Transmitter
VSWR	Voltage Standing Wave Ratio
NC	Not connect
EDGE	Enhanced data rates for GSM evolution
HSDPA	High Speed Downlink Packet Access
HSUPA	High Speed Uplink Packet Access
WCDMA	Wideband Code Division Multiple Access
USIM	Universal subscriber identity module
UMTS	Universal mobile telecommunications system
SMPS	Switch Mode Power Supply
KBC	Keypad Button Column
KBR	Keypad Button Row

**Contact us:**

**Shanghai SIMCom Wireless Solutions Ltd.**

Add: SIM Technology Building B, No.633, Jinzhong Road, Changning District, Shanghai P.R. China  
200335

Tel: +86 21 3157 5200\3157 5100

Email: [simcom@simcom.com](mailto:simcom@simcom.com)

URL: [www.simcom.com](http://www.simcom.com)

SIMCOM CONFIDENTIAL FILE